

LIGHTHOUSE
Ronan & Erwan Bouroullec

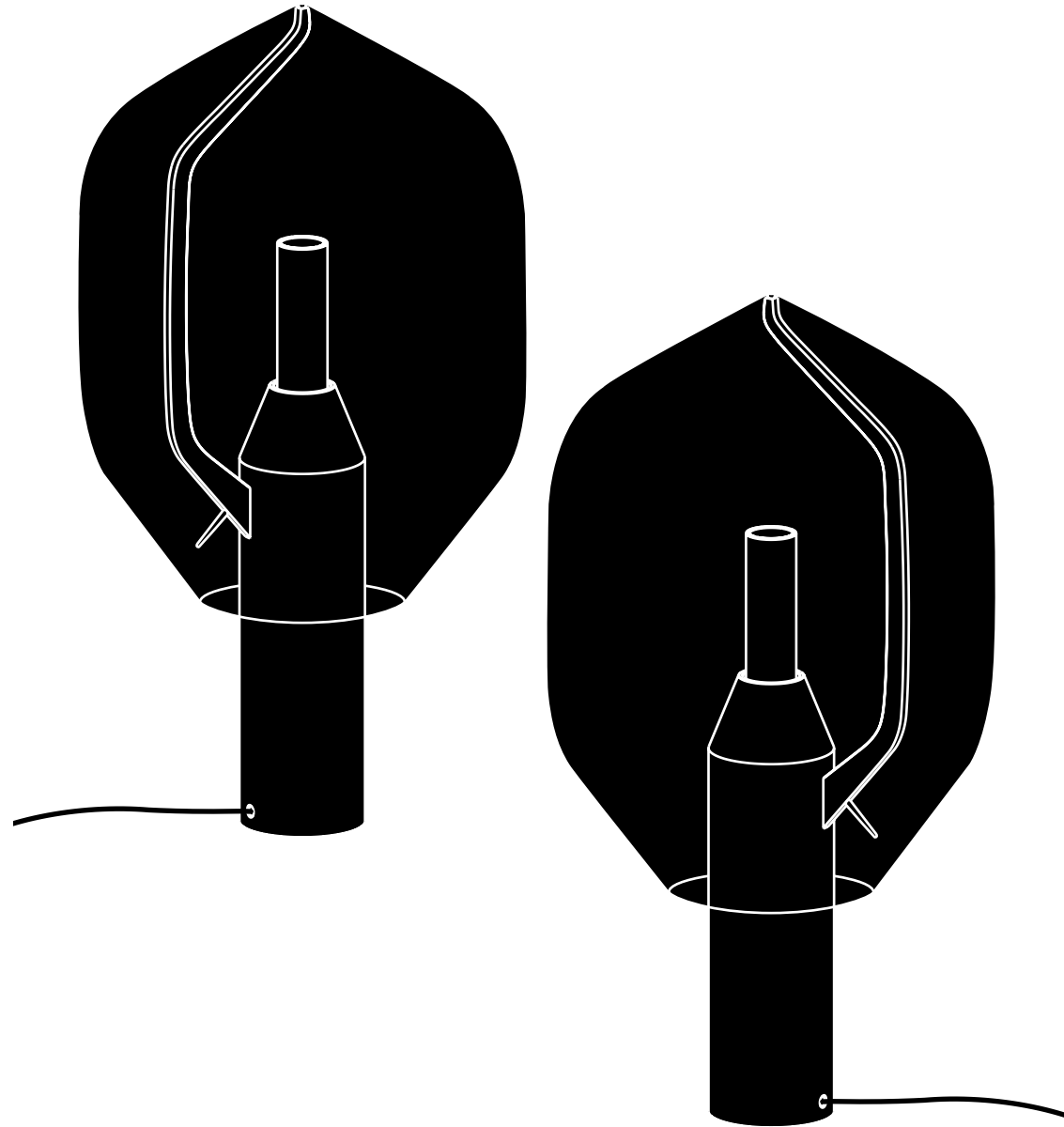

LIGHTHOUSE

Ronan & Erwan Bouroullec

A sculptural, voluptuous and enchanting object, the Lighthouse combines Venetian hand-blown glass with industrially engineered aluminium and pure marble to create an enduring contemporary classic.

THE DESIGNER

Ronan & Erwan Bouroullec have been working together for over 20 years, bonded by diligence and challenged by their distinct personalities. From designing spaces to furniture, taking on architectural projects to designing textile wall systems or comprehensive collections, the brothers maintain drawing and experimental activity as essential to the development of their work. Their designs are part of select international museums' permanent collections, including the Musée National d'Art Moderne, Centre Pompidou and the Musée des Arts Décoratifs in Paris, New York's MoMA, the Art Institute of Chicago, the Design Museum in London, and the Museum Boijmans van Beuningen in Rotterdam.



General Information

IMPORTANT, RETAIN FOR FUTURE REFERENCE: READ CAREFULLY

DESIGN
2010

DESCRIPTION
Table Light

MATERIALS
Hand blown glass, anodised aluminium, marble

DIMENSIONS
T1: H695mm, shade Ø370mm × H465mm, base Ø100mm, cable L2250mm, 10.3kg

LIGHT SOURCE
T1: G9, 1x max 75W, 110/120V, braided fabric cable, integrated dimmable on/off switch

COLOURS
Grey blown glass, matt Carrara white marble with light grey cable
Grey blown glass, matt Marquina black marble with black cable
Grey blown glass, matt Rouge du Roi red marble with black cable
Amber blown glass, matt Marquina black marble with black cable
Amber blown glass, matt Dark Emperador brown marble with black cable

Installation

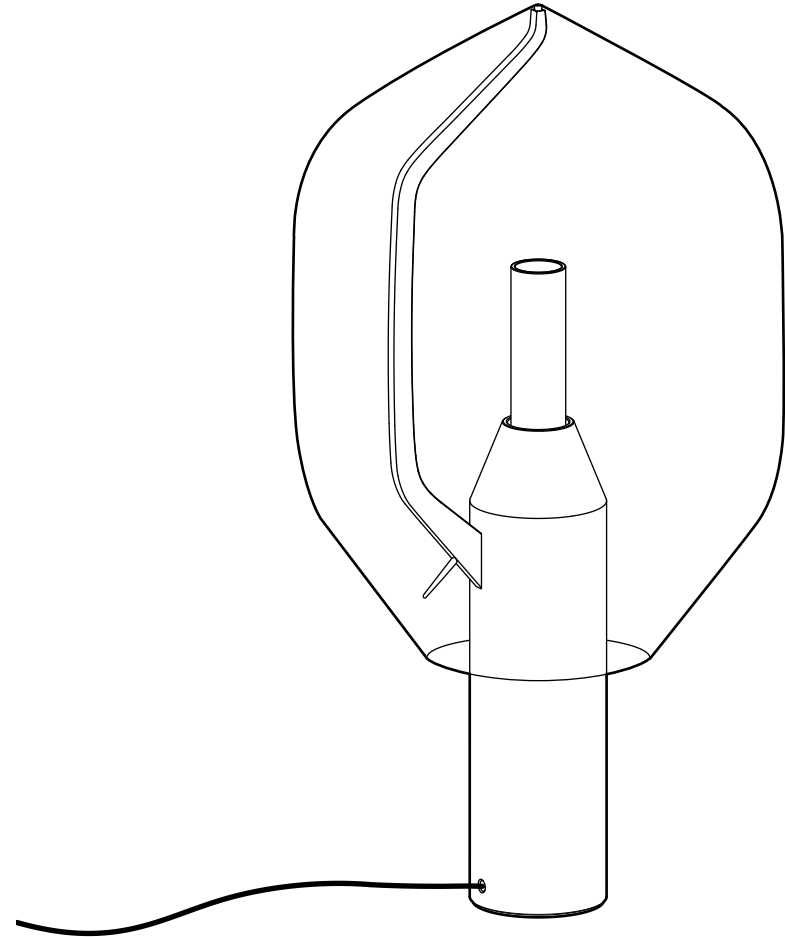

1. Carefully unpack the base (A) of the luminaire and position carefully on a flat, stable surface.
2. Insert light bulb (B) using the packaging or a cloth to hold. Avoid direct skin contact with the metal loops of the bulb as the oil or grease from hands could shorten the life of the bulb.
3. Taking care not to squeeze when handling, lower the glass diffuser over the light bulb and gently push into place.

NOTE: DO NOT overtighten. The glass diffuser is very thin and fragile. Mishandling can easily cause it to break if the proper attention is not taken.

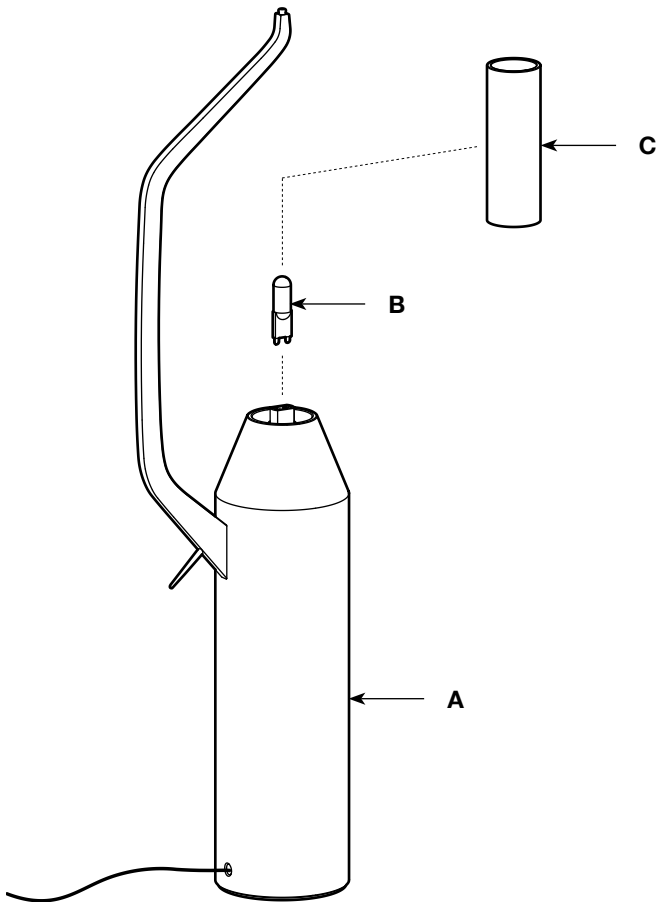

4. With one person holding the base steady, carefully lift the glass shade over the top of the arm of the base at an angle, as shown in the diagram.
NOTE: DO NOT attempt to install without a step or ladder if the base is positioned on a surface above waist-height. The weight of the shade is not evenly distributed and lifting the shade without being able to properly support it could result in damage.

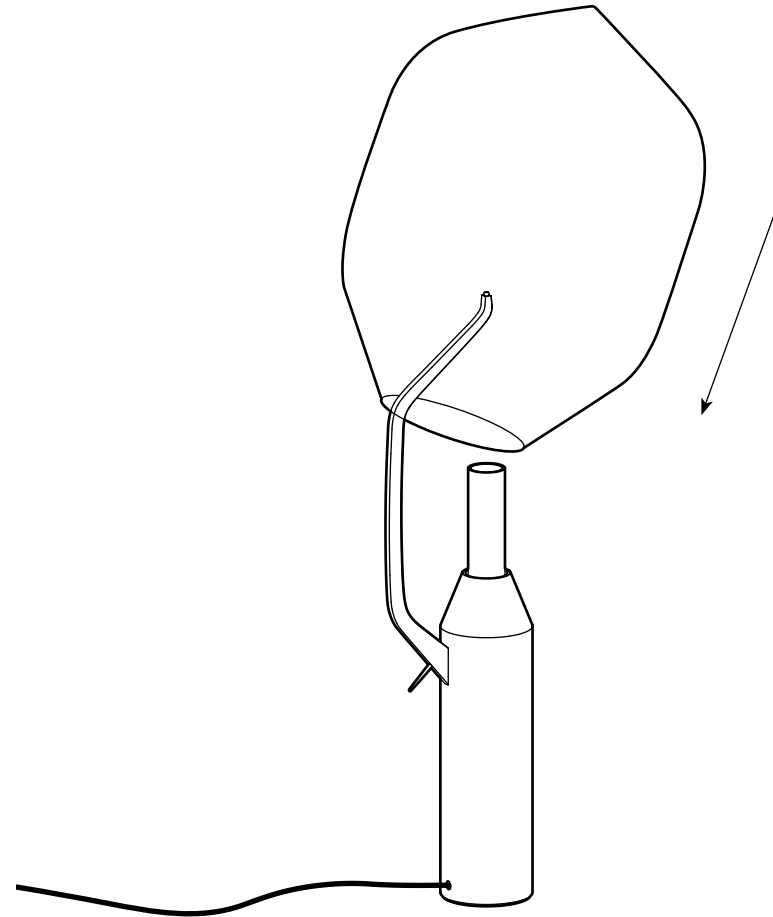

-
5. Carefully slide the glass shade down over the length of the arm until it reaches the support arm (*)
-

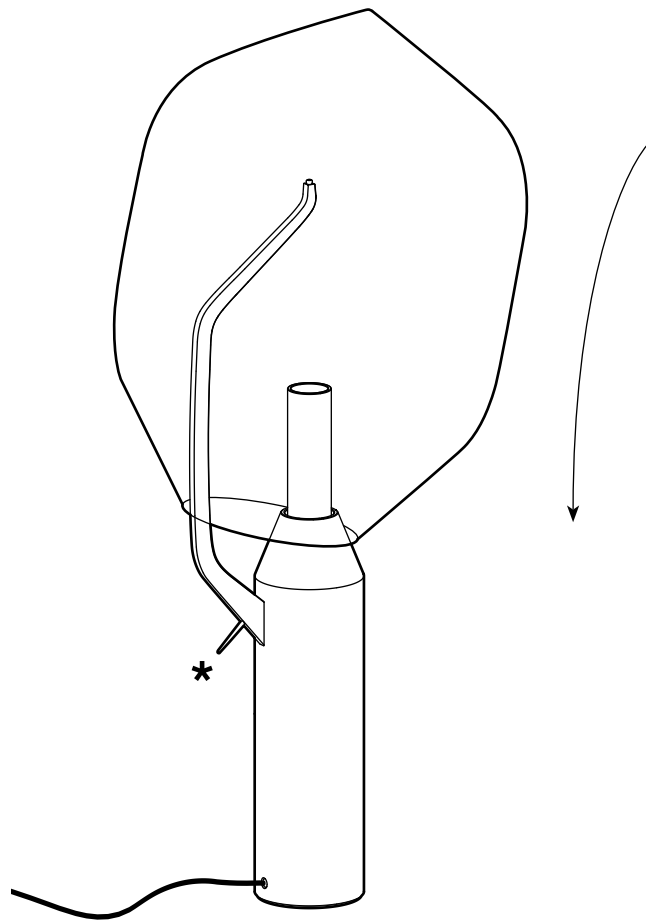

6. Carefully manoeuvre the glass shade over the support arm (*).
The glass thickness may vary by several mm round the opening of the glass shade and may not be cut perfectly circular. This may result in some difficulty getting the shade to fit over the support arm (*). Should this occur, it may be necessary to turn the shade as it comes into contact with the arm so that the longest diameter of the opening aligns with it. This should allow the glass to slip past.
7. Continue lowering the glass until it is supported by the main arm and can balance unaided.
8. Due to the variation in thickness across the glass shade, the distribution of weight is not even on all sides. As a result, the shade may not be level when installed. When the glass shade is in place over the base, turn it until the glass leans against the support arm (*) and the distance between the glass edge and the marble base (L and R) are approximately equal on both sides. This is the best balance position for the shade.
-

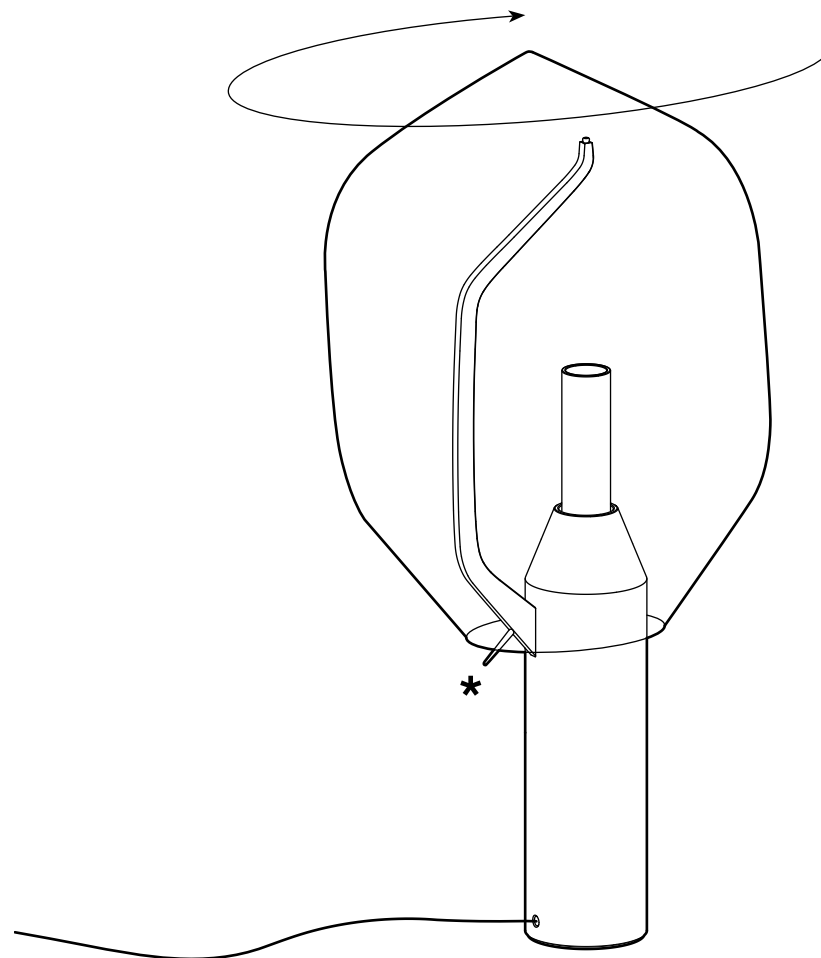

Important Information

Established & Sons disclaims any responsibility deriving from incorrect use of the mentioned object. Please read these instructions in full prior to handling. Keep these instructions for future reference.

NOTE: This item is heavy! We advise 2 people are available to assemble.
DO NOT attempt to move without first carefully removing the shade.

Both popular for sculpture and building decor, white Carrara and black Marquina marble are both characterised by the stunning veins that run across their surfaces. These inclusion 'spots and veins' are natural properties of the marble and are therefore not considered faults.

Each beautifully formed glass shade has been hand-blown by some of Italy's finest glass artisans. This is a highly technical art form, involving specialist training and skill to produce pieces of such quality. As a result, they will not have the machine-made symmetry and precision of manufactured, machine-produced glass objects and will contain slight irregularities and variations in the shape and finish.

Air bubbles are a common characteristic of both hand-blown and machine-produced glass, caused when air becomes trapped within the heated glass during the blowing process. Whilst this is kept to a minimum, it is likely that bubbles will be found in this piece. This is not considered a defect.

Variations in the thickness of the shade are also a result of the piece being hand-blown. This may result in some difficulty when fitting the shade or mean that the shade is not level when initially installed. To rectify this, please follow assembly instructions.

Maintenance Instructions

Cleaning Guidelines

ATTENTION:

DO NOT use vinegar, lemon juice or other cleaners containing acids on marble.
DO NOT use abrasive or chemical cleaners
DO NOT allow the piece to remain wet from cleaning.

Frequent dusting of this piece will help to maintain the luster of the finish. For general maintenance, the surface should be regularly dusted with a soft, dry, lint-free cloth.

Please be aware that dust is an abrasive and can scratch the surface so this must be done carefully to prevent scratching.

If wet cleaning is required, the item should be cleaned first without pressure using a soft, slightly damp cloth. It must be immediately dried with a dry, lint-free cloth. For areas that require further cleaning a very mild detergent and water solution can be used.

User Instructions

When handling the piece we advise that all jewellery, watches etc are removed to avoid scratches to the surface.

Hands should be cleaned prior to handling and free from moisturiser to prevent transference of dirt and grease from fingers. Alternatively clean, cotton gloves can be worn.

Be gentle when using the dimmer switch on the base of the piece. Overtwisting or excessive force could cause damage to the dimmer.

The product is not suitable for outdoor use.

Do not place in direct sunlight.

We advise that the piece is kept out of high traffic areas.

Do not put liquid on the electrical components.

For major maintenance or repairs, consult the retailer.

Once the product or its components are no longer used, make sure that they are disposed of correctly through the public waste disposal services.

twentieth

www.twentieth.net
sales@twentieth.net
323.904.1200

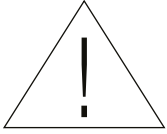

**<EN> INSTRUCTIONS FOR CORRECT
INSTALLATION AND USE
IMPORTANT!**

Before installing and whenever acting on the luminaire ensure that the electrical supply is switched OFF. Always use a qualified electrician for the installation. Contact your local electricity authority for advice. Damaged electrical parts of the luminaire should be exclusively replaced by the manufacturer or a qualified person. E&S declines all responsibility for products that are modified.

**<ES> INSTRUCCIONES PARA EL USO
Y LA INSTALACIÓN CORRECTOS
¡IMPORTANTE!**

Antes de instalarla y siempre que manipule la luminaria, asegúrese de que el suministro eléctrico esté APAGADO. Recurra siempre a un electricista cualificado para la instalación. Póngase en contacto con su compañía local de electricidad para solicitar información. Las piezas eléctricas averiadas de la luminaria solo deben ser reemplazadas por el fabricante o por una persona cualificada. E&S declina toda responsabilidad por los productos que hayan sido modificados.

**<IT> ISTRUZIONI PER UN CORRETTO
MONTAGGIO ED USO
IMPORTANTE!**

Prima di installare ed ogni volta che si interviene sull'apparecchio assicurarsi che la tensione di alimentazione sia SPENTA. Per il montaggio rivolgersi sempre ad un elettricista qualificato. Contattare l'ente locale competente per qualunque suggerimento. Le parti elettriche danneggiate devono essere sostituite esclusivamente dal costruttore o da una persona qualificata. E&S declina da ogni responsabilità per prodotti che sono stati modificati.

**<DE> INSTALLATIONS- WARTUNGS- UND
BEDIENUNGSHINWEISE
ACHTUNG!**

Licht vor Installation, Wartung und Reinigung immer von der Stromversorgung trennen. Installation sollte immer durch eine Fachkraft ausgeführt werden. Bei Fragen kontaktieren Sie Ihren Stromversorger oder einen Elektrofachbetrieb. Beschädigte Komponenten sollten nur durch den Hersteller oder durch eine Fachkraft ausgetauscht werden. E&S ist nicht haftbar fuer Produkte, die in irgendeiner Form modifiziert wurden.

**<FR> MODE D'EMPLOI POUR UNE BONNE
INSTALLATION ET UTILISATION
IMPORTANT!**

Avant l'installation et chaque fois que vous manipulez le luminaire assurez-vous que l'alimentation électrique est COUPÉE. Appelez toujours un électricien qualifié pour l'installation. Prenez conseil auprès de votre autorité d'électricité locale. Les pièces électriques endommagées du luminaire doivent être remplacées exclusivement par le fabricant ou une personne qualifiée. E&S décline toute responsabilité pour les produits modifiés.

**<PT> INSTRUÇÕES PARA A CORRETA
INSTALAÇÃO E UTILIZAÇÃO
IMPORTANTE!**

Antes de instalar e sempre que atuar sobre o candeeiro deve confirmar que a alimentação elétrica DESLIGADA. A instalação deve ser sempre feita por um electricista qualificado. Contacte a sua entidade local de electricidade para aconselhamento. As componentes elétricas danificadas do candeeiro devem ser substituídas apenas pelo fabricante ou por uma pessoa qualificada. A E&S declina qualquer responsabilidade em relação a produtos que sejam alterados.

**<AR> تعليمات التركيب والاستعمال بالطريقة الصحيحة
هام!**

قبل التركيب وقبل الشروع بأي إجراء على المصباح، تأكد من أن التيار الكهربائي مُطفأ. ينبغي أن يتم التركيب على يد فني كهرباء مختص ومؤهل. اتصل بسلطة الكهرباء المحلية للحصول على النصائح. ينبغي عدم استبدال القطع الكهربائية المتضررة داخل المصباح إلا بواسطة الشركة المُصنعة أو شخص مؤهل. لا تتحمل E&S أي مسؤولية عن المنتجات التي يتم تعديلها.

LIGHTHOUSE
Ronan & Erwan Bouroullec

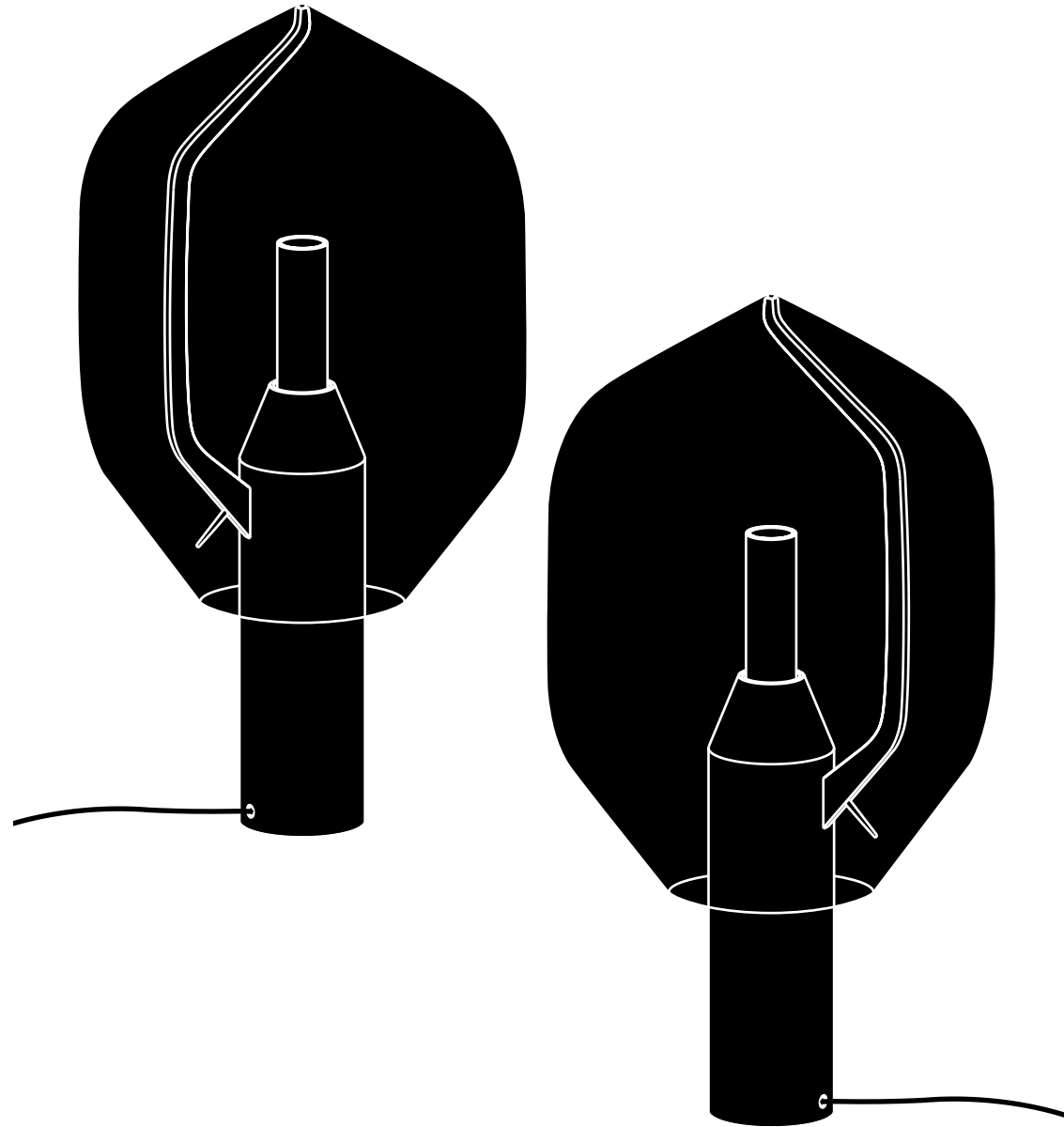

LIGHTHOUSE

Ronan & Erwan Bouroullec

A sculptural, voluptuous and enchanting object, the Lighthouse combines Venetian hand-blown glass with industrially engineered aluminium and pure marble to create an enduring contemporary classic.

THE DESIGNER

Ronan & Erwan Bouroullec have been working together for over 20 years, bonded by diligence and challenged by their distinct personalities. From designing spaces to furniture, taking on architectural projects to designing textile wall systems or comprehensive collections, the brothers maintain drawing and experimental activity as essential to the development of their work. Their designs are part of select international museums' permanent collections, including the Musée National d'Art Moderne, Centre Pompidou and the Musée des Arts Décoratifs in Paris, New York's MoMA, the Art Institute of Chicago, the Design Museum in London, and the Museum Boijmans van Beuningen in Rotterdam.



General Information

IMPORTANT, RETAIN FOR FUTURE REFERENCE: READ CAREFULLY

DESIGN
2010

DESCRIPTION
Table Light

MATERIALS
Hand blown glass, anodised aluminium, marble

DIMENSIONS
T1: H695mm, shade Ø370mm × H465mm, base Ø100mm, cable L2250mm, 10.3kg

LIGHT SOURCE
T1: G9, 1x max 75W, 220/240V, braided fabric cable, integrated dimmable on/off switch

COLOURS
Grey blown glass, matt Carrara white marble with light grey cable
Grey blown glass, matt Marquina black marble with black cable
Grey blown glass, matt Rouge du Roi red marble with black cable
Amber blown glass, matt Marquina black marble with black cable
Amber blown glass, matt Dark Emperador brown marble with black cable

Installation

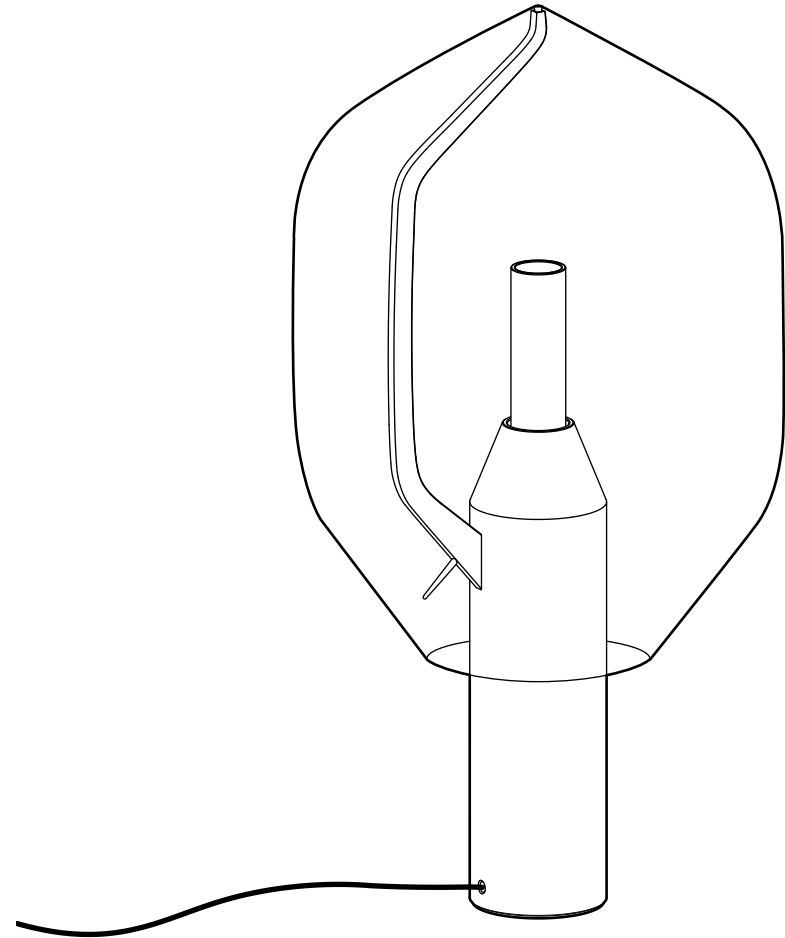

1. Carefully unpack the base (A) of the luminaire and position carefully on a flat, stable surface.
2. Insert light bulb (B) using the packaging or a cloth to hold. Avoid direct skin contact with the metal loops of the bulb as the oil or grease from hands could shorten the life of the bulb.
3. Taking care not to squeeze when handling, lower the glass diffuser over the light bulb and gently push into place.

NOTE: DO NOT overtighten. The glass diffuser is very thin and fragile. Mishandling can easily cause it to break if the proper attention is not taken.

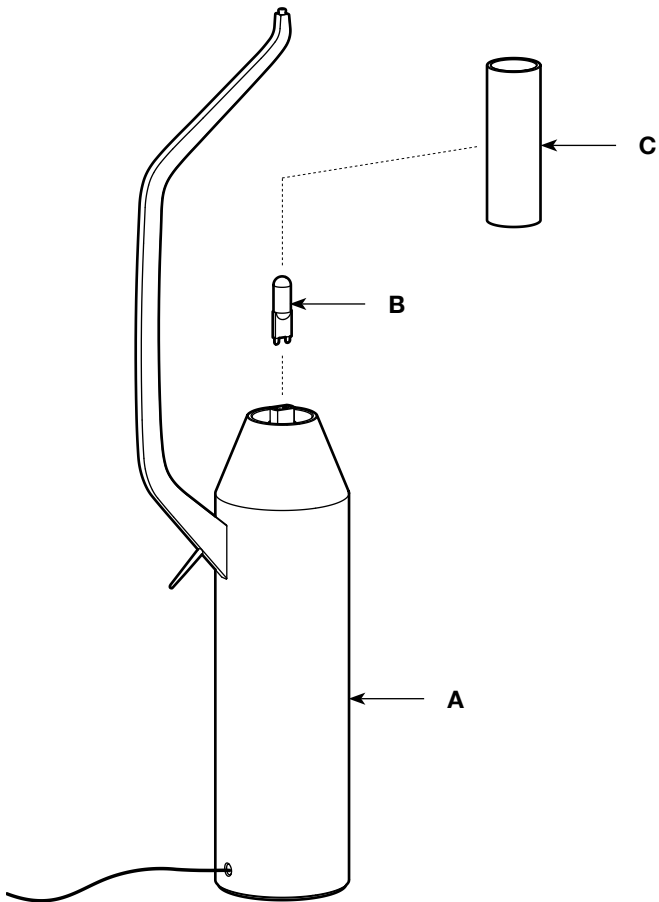

4. With one person holding the base steady, carefully lift the glass shade over the top of the arm of the base at an angle, as shown in the diagram.
NOTE: DO NOT attempt to install without a step or ladder if the base is positioned on a surface above waist-height. The weight of the shade is not evenly distributed and lifting the shade without being able to properly support it could result in damage.

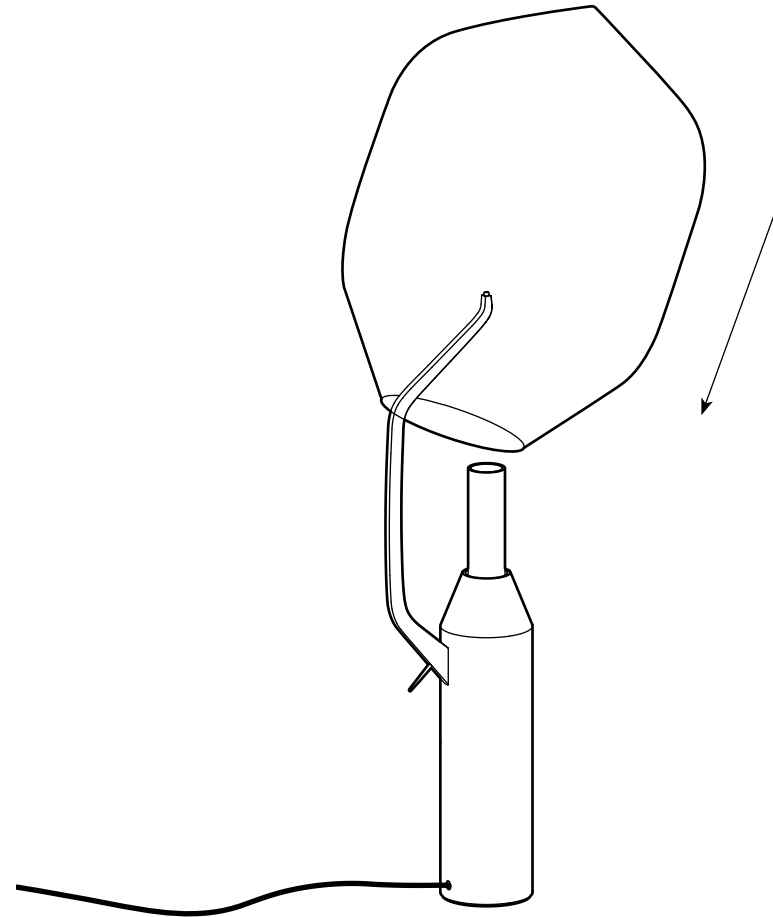

-
5. Carefully slide the glass shade down over the length of the arm until it reaches the support arm (*)
-

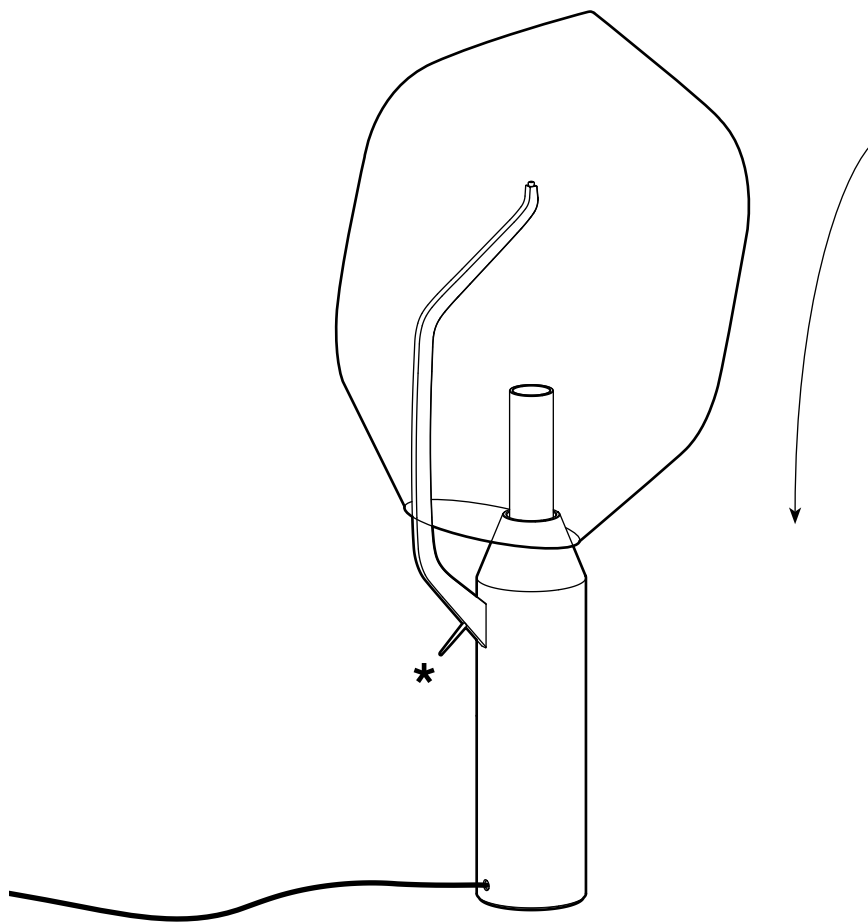

6. Carefully manoeuvre the glass shade over the support arm (*).
The glass thickness may vary by several mm round the opening of the glass shade and may not be cut perfectly circular. This may result in some difficulty getting the shade to fit over the support arm (*). Should this occur, it may be necessary to turn the shade as it comes into contact with the arm so that the longest diameter of the opening aligns with it. This should allow the glass to slip past.
7. Continue lowering the glass until it is supported by the main arm and can balance unaided.
8. Due to the variation in thickness across the glass shade, the distribution of weight is not even on all sides. As a result, the shade may not be level when installed. When the glass shade is in place over the base, turn it until the glass leans against the support arm (*) and the distance between the glass edge and the marble base (L and R) are approximately equal on both sides. This is the best balance position for the shade.
-

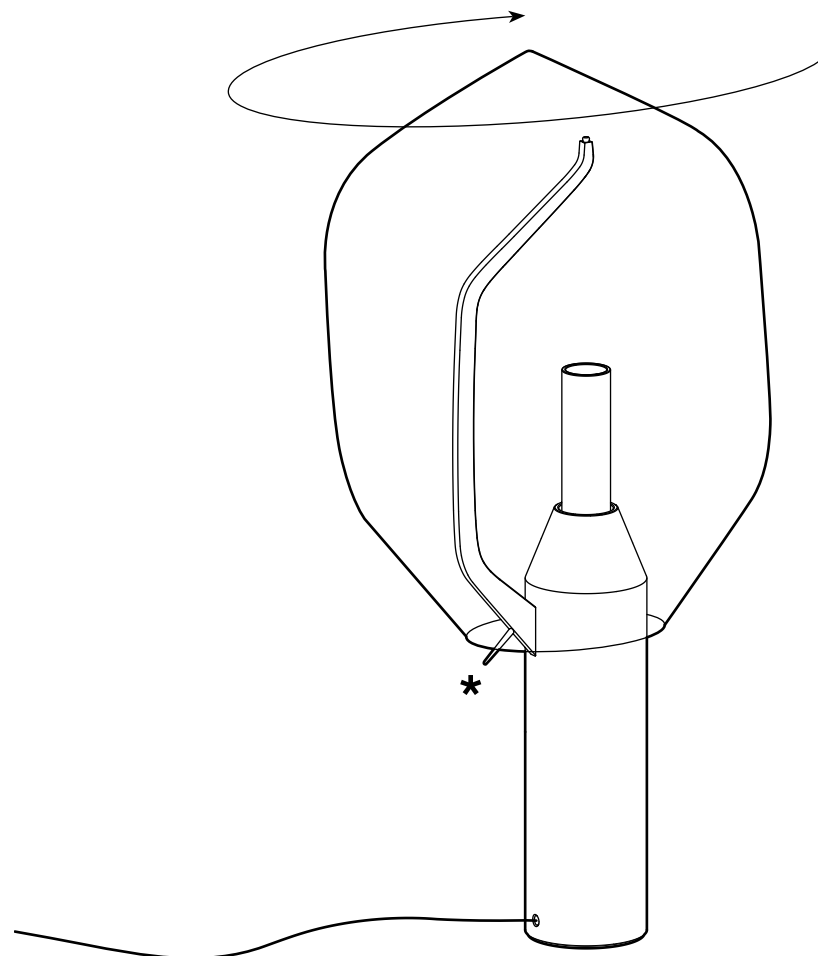

Important Information

Established & Sons disclaims any responsibility deriving from incorrect use of the mentioned object. Please read these instructions in full prior to handling. Keep these instructions for future reference.

NOTE: This item is heavy! We advise 2 people are available to assemble.
DO NOT attempt to move without first carefully removing the shade.

Both popular for sculpture and building decor, white Carrara and black Marquina marble are both characterised by the stunning veins that run across their surfaces. These inclusion 'spots and veins' are natural properties of the marble and are therefore not considered faults.

Each beautifully formed glass shade has been hand-blown by some of Italy's finest glass artisans. This is a highly technical art form, involving specialist training and skill to produce pieces of such quality. As a result, they will not have the machine-made symmetry and precision of manufactured, machine-produced glass objects and will contain slight irregularities and variations in the shape and finish.

Air bubbles are a common characteristic of both hand-blown and machine-produced glass, caused when air becomes trapped within the heated glass during the blowing process. Whilst this is kept to a minimum, it is likely that bubbles will be found in this piece. This is not considered a defect.

Variations in the thickness of the shade are also a result of the piece being hand-blown. This may result in some difficulty when fitting the shade or mean that the shade is not level when initially installed. To rectify this, please follow assembly instructions.

Maintenance Instructions

Cleaning Guidelines

ATTENTION:

DO NOT use vinegar, lemon juice or other cleaners containing acids on marble.
DO NOT use abrasive or chemical cleaners
DO NOT allow the piece to remain wet from cleaning.

Frequent dusting of this piece will help to maintain the luster of the finish. For general maintenance, the surface should be regularly dusted with a soft, dry, lint-free cloth.

Please be aware that dust is an abrasive and can scratch the surface so this must be done carefully to prevent scratching.

If wet cleaning is required, the item should be cleaned first without pressure using a soft, slightly damp cloth. It must be immediately dried with a dry, lint-free cloth. For areas that require further cleaning a very mild detergent and water solution can be used.

User Instructions

When handling the piece we advise that all jewellery, watches etc are removed to avoid scratches to the surface.

Hands should be cleaned prior to handling and free from moisturiser to prevent transference of dirt and grease from fingers. Alternatively clean, cotton gloves can be worn.

Be gentle when using the dimmer switch on the base of the piece. Overtwisting or excessive force could cause damage to the dimmer.

The product is not suitable for outdoor use.

Do not place in direct sunlight.

We advise that the piece is kept out of high traffic areas.

Do not put liquid on the electrical components.

For major maintenance or repairs, consult the retailer.

Once the product or its components are no longer used, make sure that they are disposed of correctly through the public waste disposal services.

twentieth

www.twentieth.net
sales@twentieth.net
323.904.1200

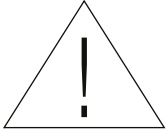

**<EN> INSTRUCTIONS FOR CORRECT
INSTALLATION AND USE
IMPORTANT!**

Before installing and whenever acting on the luminaire ensure that the electrical supply is switched OFF. Always use a qualified electrician for the installation. Contact your local electricity authority for advice. Damaged electrical parts of the luminaire should be exclusively replaced by the manufacturer or a qualified person. E&S declines all responsibility for products that are modified.

**<ES> INSTRUCCIONES PARA EL USO
Y LA INSTALACIÓN CORRECTOS
¡IMPORTANTE!**

Antes de instalarla y siempre que manipule la luminaria, asegúrese de que el suministro eléctrico esté APAGADO. Recurra siempre a un electricista cualificado para la instalación. Póngase en contacto con su compañía local de electricidad para solicitar información. Las piezas eléctricas averiadas de la luminaria solo deben ser reemplazadas por el fabricante o por una persona cualificada. E&S declina toda responsabilidad por los productos que hayan sido modificados.

**<IT> ISTRUZIONI PER UN CORRETTO
MONTAGGIO ED USO
IMPORTANTE!**

Prima di installare ed ogni volta che si interviene sull'apparecchio assicurarsi che la tensione di alimentazione sia SPENTA. Per il montaggio rivolgersi sempre ad un elettricista qualificato. Contattare l'ente locale competente per qualunque suggerimento. Le parti elettriche danneggiate devono essere sostituite esclusivamente dal costruttore o da una persona qualificata. E&S declina da ogni responsabilità per prodotti che sono stati modificati.

**<DE> INSTALLATIONS- WARTUNGS- UND
BEDIENUNGSHINWEISE
ACHTUNG!**

Licht vor Installation, Wartung und Reinigung immer von der Stromversorgung trennen. Installation sollte immer durch eine Fachkraft ausgeführt werden. Bei Fragen kontaktieren Sie Ihren Stromversorger oder einen Elektrofachbetrieb. Beschädigte Komponenten sollten nur durch den Hersteller oder durch eine Fachkraft ausgetauscht werden. E&S ist nicht haftbar fuer Produkte, die in irgendeiner Form modifiziert wurden.

**<FR> MODE D'EMPLOI POUR UNE BONNE
INSTALLATION ET UTILISATION
IMPORTANT!**

Avant l'installation et chaque fois que vous manipulez le luminaire assurez-vous que l'alimentation électrique est COUPÉE. Appelez toujours un électricien qualifié pour l'installation. Prenez conseil auprès de votre autorité d'électricité locale. Les pièces électriques endommagées du luminaire doivent être remplacées exclusivement par le fabricant ou une personne qualifiée. E&S décline toute responsabilité pour les produits modifiés.

**<PT> INSTRUÇÕES PARA A CORRETA
INSTALAÇÃO E UTILIZAÇÃO
IMPORTANTE!**

Antes de instalar e sempre que atuar sobre o candeeiro deve confirmar que a alimentação elétrica DESLIGADA. A instalação deve ser sempre feita por um electricista qualificado. Contacte a sua entidade local de electricidade para aconselhamento. As componentes elétricas danificadas do candeeiro devem ser substituídas apenas pelo fabricante ou por uma pessoa qualificada. A E&S declina qualquer responsabilidade em relação a produtos que sejam alterados.

**<AR> تعليمات التركيب والاستعمال بالطريقة الصحيحة
هام!**

قبل التركيب وقبل الشروع بأي إجراء على المصباح، تأكد من أن التيار الكهربائي 'مقطعاً'. ينبغي أن يتم التركيب على يد فني كهرباء مختص ومؤهل. اتصل بسلطة الكهرباء المحلية للحصول على النصائح. ينبغي عدم استبدال القطع الكهربائية المتضررة داخل المصباح إلا بواسطة الشركة الأم صُنعة أو شخص مؤهل. لا تتحمل E&S أي مسؤولية عن المنتجات التي يتم تعديلها.