

# OURANOS I SCONCE

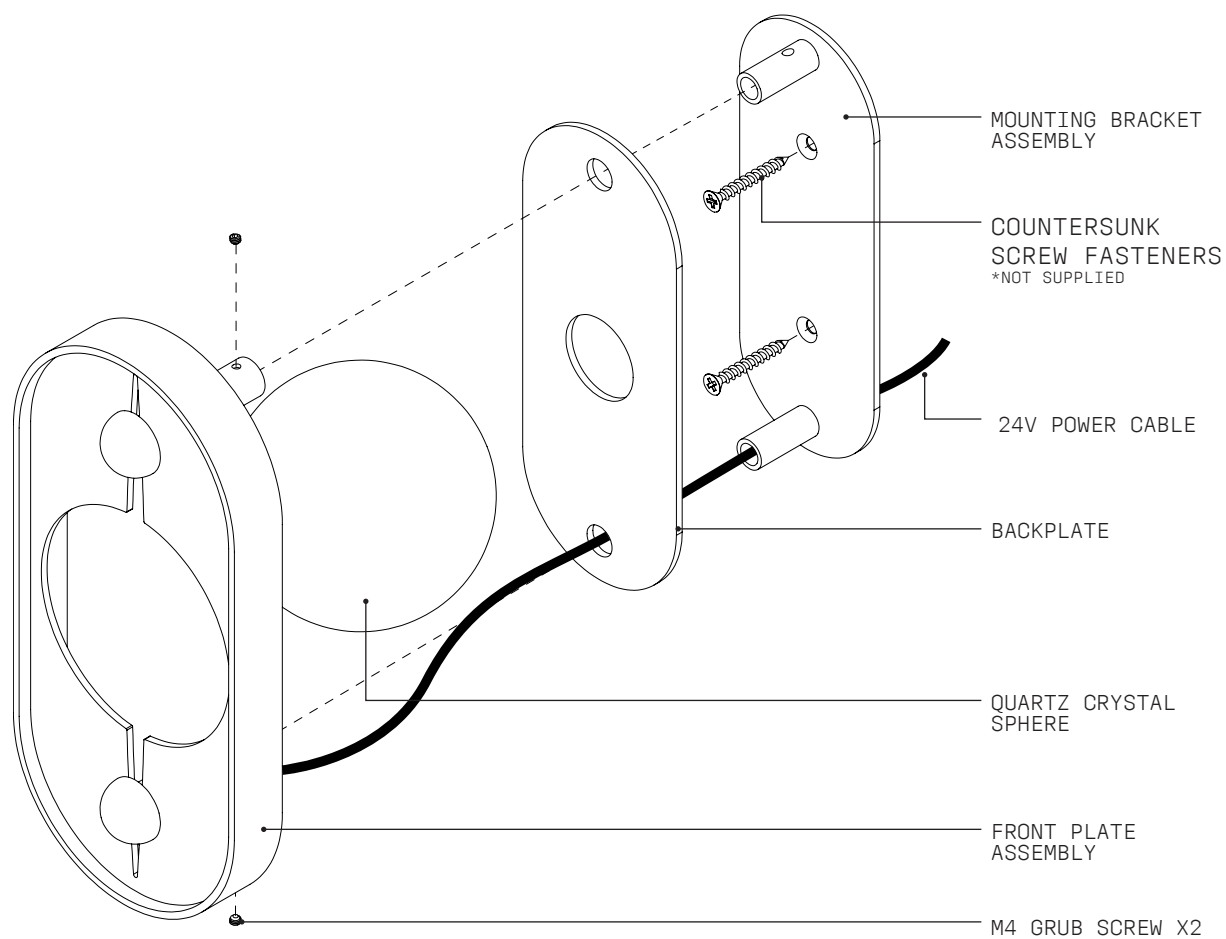



## WARNING: SHOCK HAZARD

May result in serious injury or death.  
ENSURE POWER IS OFF before commencing any work.



## WARNING: ELECTRICAL

ALL ELECTRICAL connections must be made by a qualified electrician in accordance with the regulations and codes governing the area for which the CHRISTOPHER BOOTS Fixture is intended to be installed in. Failure to do so may result in serious harm or damage to property and life, at the owner's liability and expense.

CHRISTOPHER BOOTS will not be held liable for any damage caused from installation.



## WARNING: STRUCTURAL

Ensure that the substrate is securely installed and is in accordance with local building regulations. Failure to do so may potentially result in serious harm or damage of property, at the owner's liability and expense.

CHRISTOPHER BOOTS will not be held liable for any damage caused from installation.



Refer to supplied WIRING DIAGRAM.



**1**

Wearing gloves, unpack the SCONCE with care ensuring not to scratch component surfaces.

Remove M4 GRUB SCREWS from top and bottom STANDOFFS.

Remove FRONT PLATE ASSEMBLY from MOUNTING BRACKET ASSEMBLY by sliding each STANDOFF from each corresponding BRASS COUPLER.

Ensure POWER CABLE passes through BRASS BACKPLATE and the BRASS COUPLER.

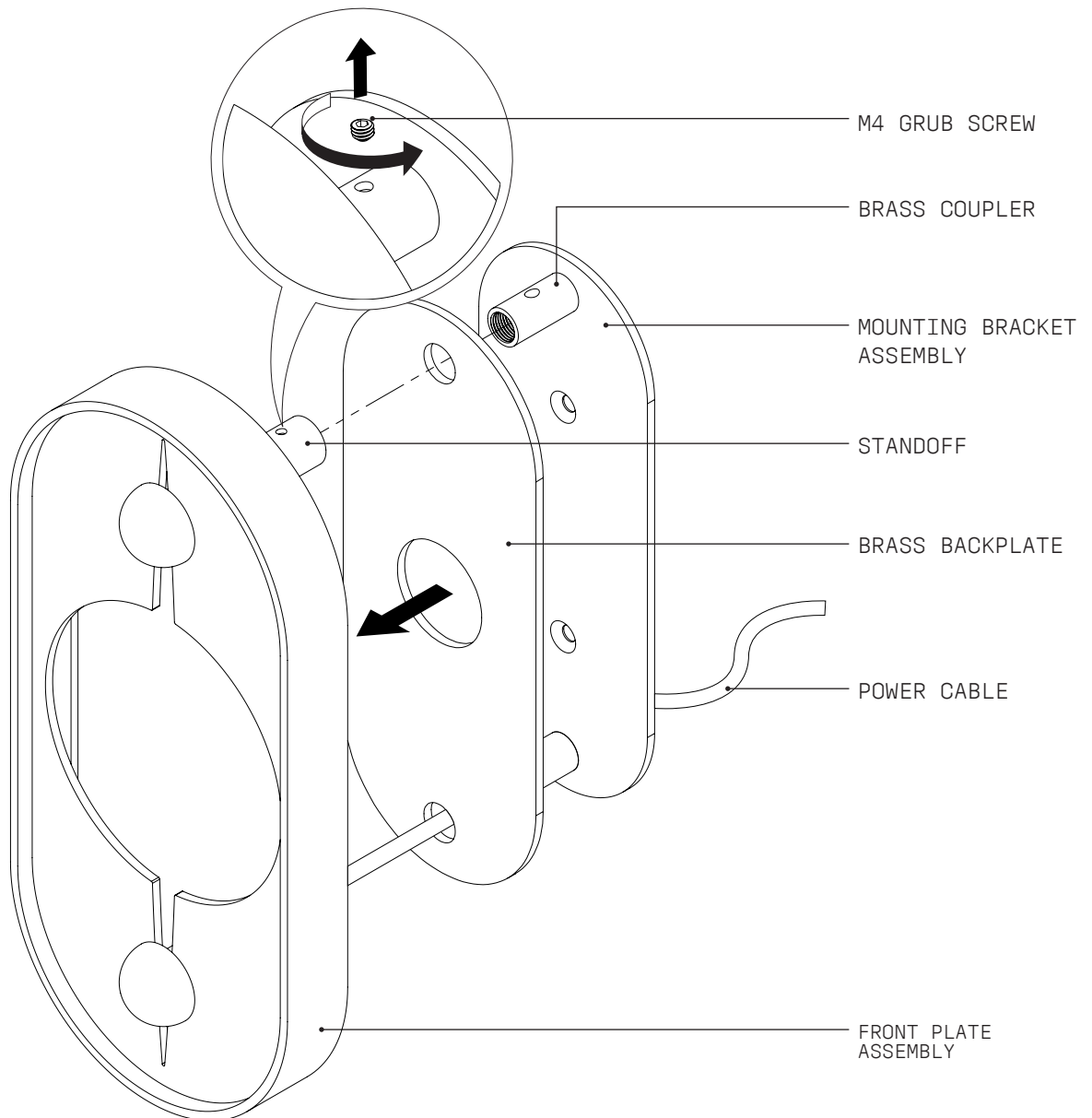

- 2 Separate the mounting bracket assembly which will be used as a template for sconce installation.  
Mark out the two WALL FIXING HOLES and POWER FEED HOLE, as well as a WALL CAVITY location for the power supply.

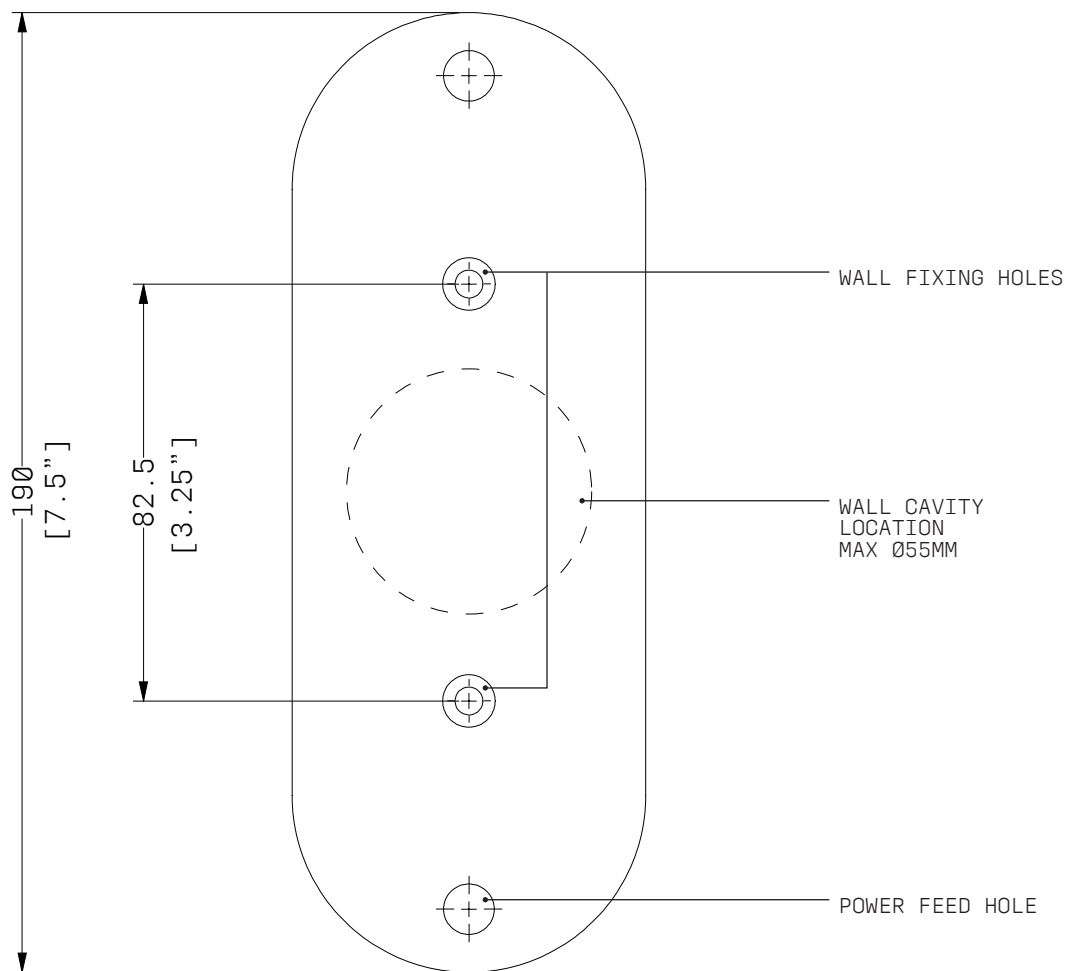

- 3 Remove the MOUNTING BRACKET ASSEMBLY and cut the POWER FEED HOLE.  
 Using appropriate 2x COUNTERSUNK SCREW FASTENERS, attach MOUNTING BRACKET ASSEMBLY to wall substrate.

Feed power supply into WALL CAVITY or remotely locate and prepare 24V DC power supply for connection to OURANOS SCONCE.

Refer to supplied WIRING DIAGRAM. →

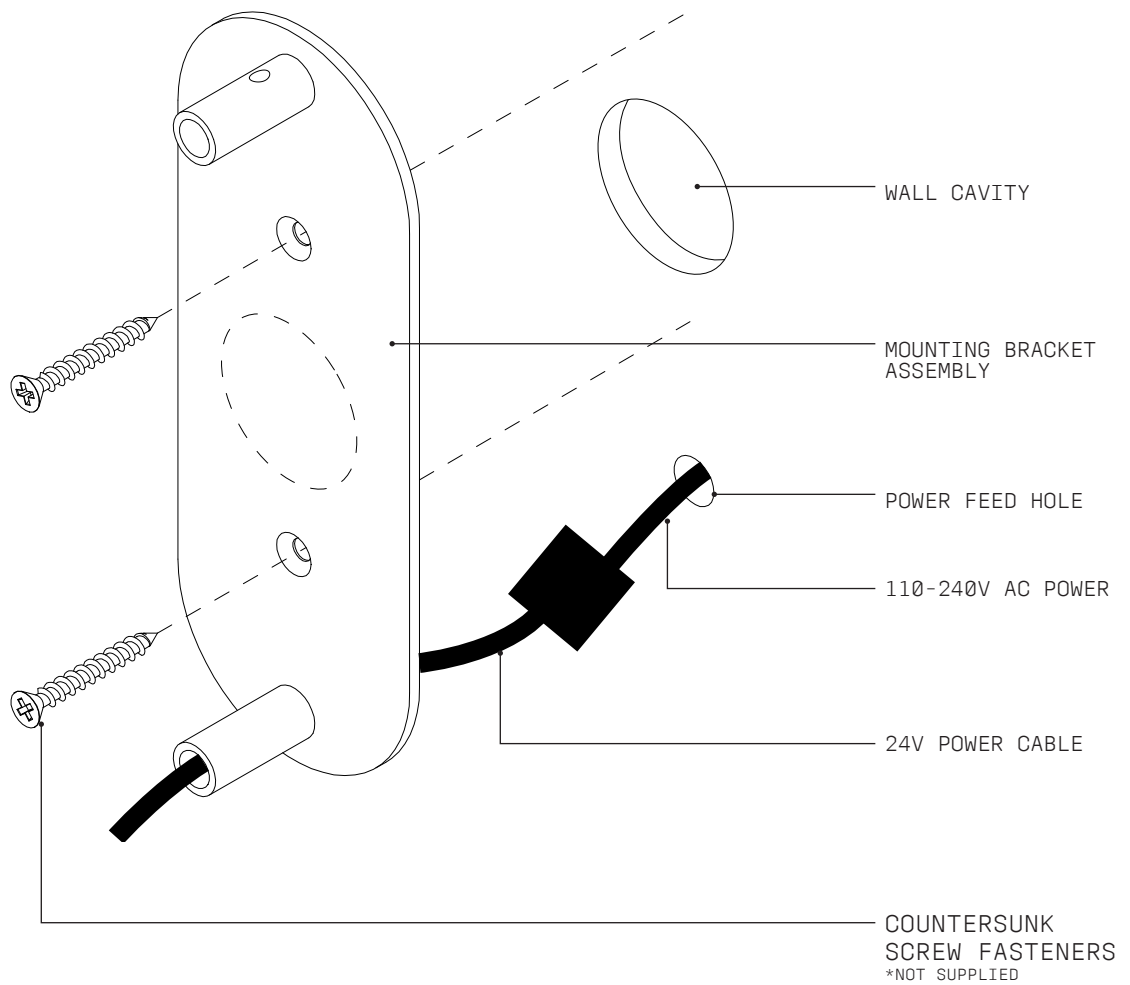

- 4 Place QUARTZ SPHERE between BACKPLATE and SCONCE FRAME.  
 Slide BACKPLATE over BRASS TUBES attached to MOUNTING BRACKET, ensuring to feed 24V POWER CABLE through.  
 Slide STANDOFFS over BRASS TUBES, holding QUARTZ SPHERE inbetween.

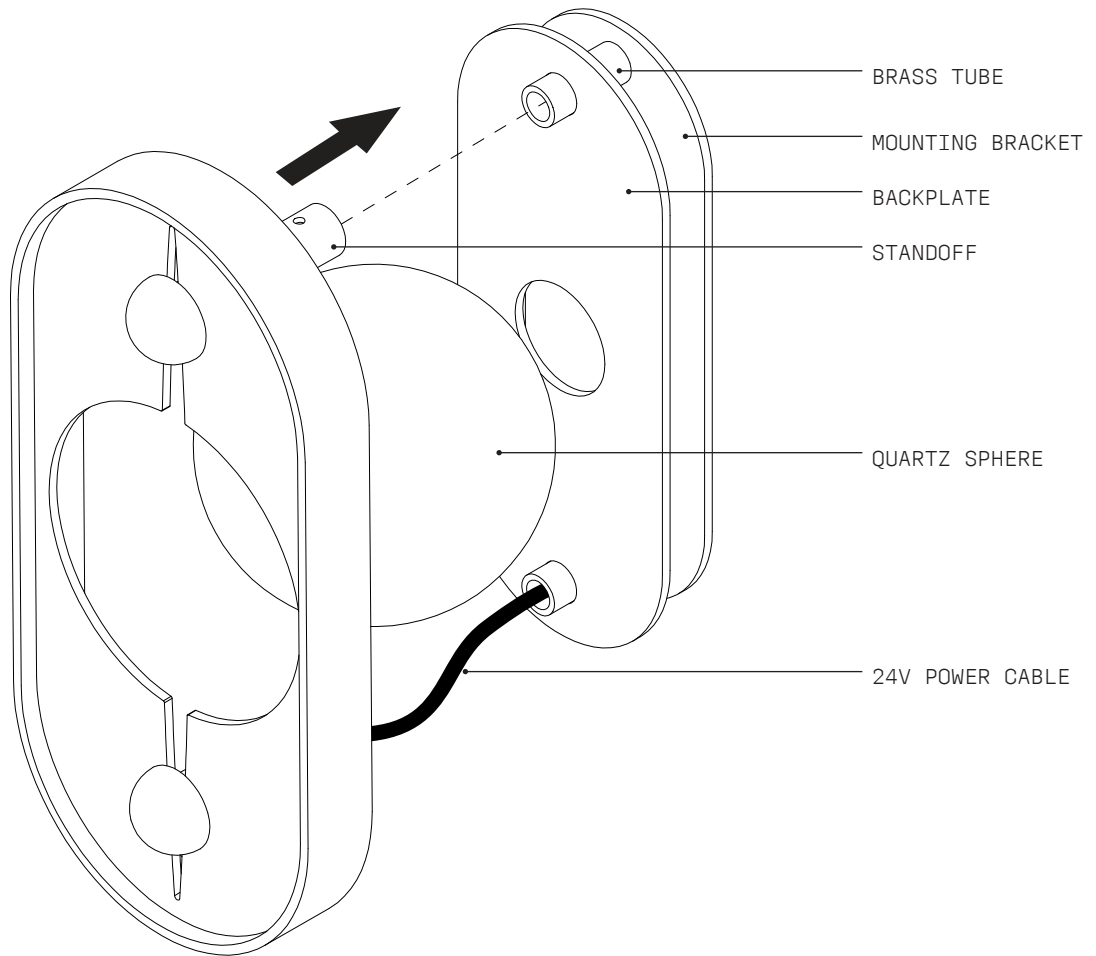

- 5 Carefully fasten M4 GRUB SCREWS through STANDOFFS, holding the FRONT PLATE ASSEMBLY into position. Ensure M4 GRUB SCREWS sit in small notch on each STANDOFF. DO NOT fasten too tightly, as M4 threads are delicate.

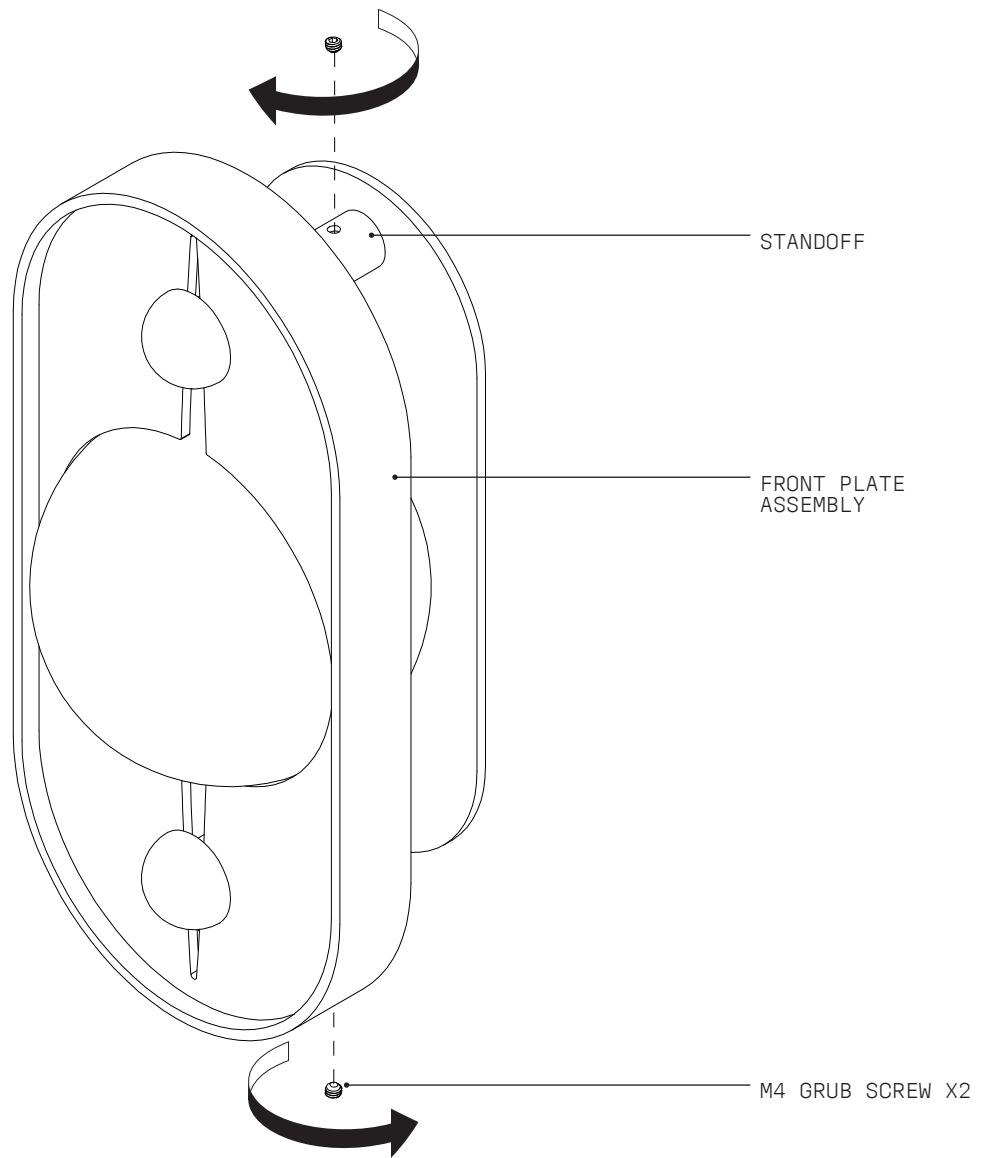

- 6 — Conduct a final visual assessment of the fixture to ensure all parts have been properly fitted and secured. Once satisfied that everything is in working order, remove all remaining protective material which will now complete the installation process.

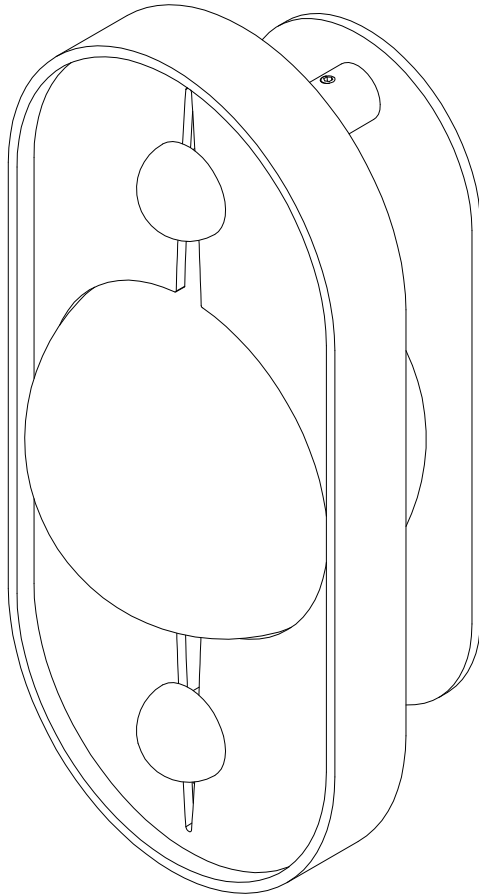

FINISH



The OURANOS WALL SCONCE is for indoor use only and operable to a maximum ambient temperature of 60° celsius. The lamping of this luminaire, is a non-user replaceable source and must only be replaced by CHRISTOPHER BOOTS, an appointed agent and/or qualified professional of CHRISTOPHER BOOTS. Should your pendant require relamping, please contact CHRISTOPHER BOOTS by sending an email to [sales@christopherboots.com](mailto:sales@christopherboots.com) to make the necessary arrangements.



THE LIGHT SOURCE CONTAINED IN THIS LUMINAIRE SHALL ONLY BE REPLACED BY THE MANUFACTURER OR THEIR REPRESENTATIVE AGENT OR A SIMILAR QUALIFIED PERSON

#### CARE INSTRUCTIONS:

OURANOS is a solid fixture that will require very little maintenance over the years, however changes in appearance of hand applied finishes or unlacquered finishes will vary as these (finishes) are designed to age in appearance. If your OURANOS is treated with care, it will shine brightly for many years to come. We recommend some general tips to help keep it shining its brightest:

- Remove dust by simply running an electrostatic duster or dry cloth every few weeks over all exposed surfaces.
- Under no circumstances should the fixture be cleaned with any type of liquids/detergents or solvents.
- If more than dusting is required, please contact us at:  
[sales@christopherboots.com](mailto:sales@christopherboots.com)
- We recommend the use of micro fibre cloths.

## WARRANTY

1. CHRISTOPHER BOOTS offers a 36 month / 3 year warranty from date of receipt of balance payment on all light fittings supplied (not installation) against mechanical defects.
2. CHRISTOPHER BOOTS will repair or replace defective components or product within this warranty period.
3. Warranty for componentry includes:
4. LED lamps and strips: 3 years / 36 months after receipt.
5. LED POWER SUPPLYs 60w: 3 years / 36 months after receipt.
6. LED POWER SUPPLYs 100w + 150w: 5 years / 60 months after receipt.
7. If unsure, please contact sales@christopherboots.com

### Christopher Boots will not be held responsible for the following:

1. Damage caused by improper cleaning solutions or methods.
2. Damage caused by improper installation or assembly by customer or customer's agent.
3. Damage caused by improper use of LED:
4. Damage caused by exposure to weather or improper environment – client to check IP rating prior to purchase.
5. Changes in appearance of hand applied finishes or unlacquered finishes.  
\*Please note that these finishes are designed to age in appearance.
6. Any costs of installation, removal, or re-installation.
7. Restoration, repair work & any parts purchased separately from supplied light fixtures.
8. Damage caused during shipping – all items are packed specifically for global transport.

## DAMAGES

1. Damages must be documented and reported within 7 business days of receipt.
2. Photo evidence will be required upon reporting of damage claim.
3. CHRISTOPHER BOOTS is not responsible for repair or replacement of damages reported after this time.
4. If damage has occurred in shipping – all packaging must be retained by receiver. Failure to do so may invalidate any claim.

## RETURNS

1. Because of the hand-made nature of our product, we are not able to offer returns.
2. Warranty claims, however will require client to cover shipping enroute back for repair

#### A. DEFINITIONS

In this warranty Australian Consumer Law means the Australian consumer law set out in Schedule 2 to the Competition and Consumer Act 2010.

Goods means the product or equipment that was purchased in Australia and listed in the Applicable Product Ranges below.

Manufacturer, We or Us means:  
CHRISTOPHER BOOTS Pty Ltd  
ABN 20 161 794 574

Supplier means the authorized distributor or the licensed electrical contractor that sold you the Goods.

You means you, the original end-user purchaser of the Goods.

#### B. WARRANTY PERIOD AND DETAILS

The products detailed above are covered by a warranty against manufacturing faults and defects, provided that:

The product is properly installed, and installation is consistent with the manufacturer's instructions, and is installed by suitably trained and qualified installer. The product is not subjected to any unauthorised modifications.

The product is only used for the purpose of decorative illumination, in line with its designated purpose.

The product use is in normal conditions.

Any faults or defects attributable to the misuse, abuse, accident or non-observance of the manufacturer's instructions on the part of the user are specifically excluded.

#### C. EXTENT OF THE WARRANTY

GOODS that prove defective within the Warranty Period by reason or improper workmanship or faulty material, we may, at our own discretion, either repair or replace the GOODS without charge.

This warranty does not cover any cost related to removal, shipping to or from the return point, or reinstallation of the replace or repair item.

Any parts of the GOODS replaced during repairs or any product replaced remain the property of CHRISTOPHER BOOTS Pty Ltd.

In the event of the GOODS being replaced during the WARRANTY PERIOD, the warranty on the replacement GOODS will expire on the same date as the WARRANTY PERIOD of the original GOODS they are replacing.

#### D. APPLICABLE DATE/COMMENCEMENT OF WARRANTY

This warranty commences from the date of purchase from the point of purchase from CHRISTOPHER BOOTS Pty Ltd. The details of the point of purchase, as well as all contact information for warranty claims and queries, are detailed below;

CHRISTOPHER BOOTS Pty Ltd.  
369 Gore St. Fitzroy, Vic. Australia 3065  
Ph: +61 3 9417 6501  
Email: sales@christopherboots.com

#### E. CLAIM PROCESS

The customer claim process is as follows; The customer can make a claim, or enquire about the claim process, by contacting the company as detailed above.

The customer must provide a proof of purchase from the SUPPLIER.

Before returning any goods for a warranty claim, the customer must obtain authorization and a Goods Return Authorisation (GRA) notice. The customer, at their own expense, then forwards the goods, clearly marked with the GRA notice and with provision for return freight, to CHRISTOPHER BOOTS Pty Ltd (see above).

Upon receipt of the goods, CHRISTOPHER BOOTS Pty Ltd will review the claim, and proof of purchase.

If accepted as a valid warranty claim within the terms as described in this document, CHRISTOPHER BOOTS Pty Ltd will either make suitable repairs or provide an equivalent replacement product.

If the claim is rejected, the customer will be provided with a full explanation, and if requested, the goods will be returned.

#### IMPORTANT:

Our goods come with guarantees that cannot be excluded under the Australian Consumer Law. You are entitled to a replacement or refund for a major failure and for compensation for any other reasonably foreseeable loss or damage. You are also entitled to have the goods repaired or replaced if the goods fail to be of acceptable quality and the failure does not amount to a major failure.

# OURANOS II PENDANT

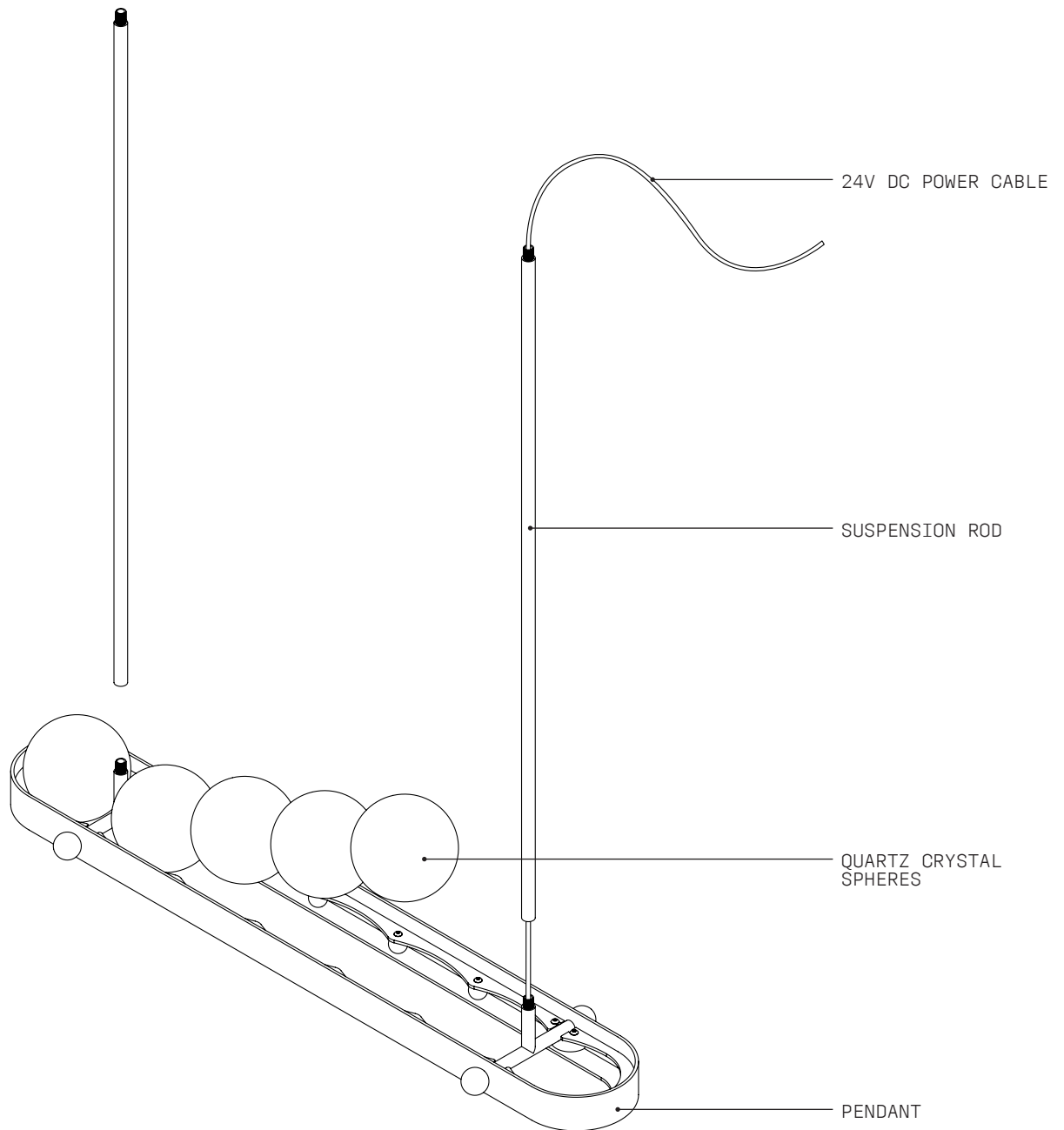



**WARNING:  
SHOCK HAZARD**

May result in serious injury or death.  
ENSURE POWER IS OFF before commencing any work.



**WARNING:  
ELECTRICAL**

ALL ELECTRICAL connections must be made by a qualified electrician in accordance with the regulations and codes governing the area for which the CHRISTOPHER BOOTS Fixture is intended to be installed in. Failure to do so may result in serious harm or damage to property and life, at the owner's liability and expense.

CHRISTOPHER BOOTS will not be held liable for any damage caused from installation.



**WARNING:  
STRUCTURAL**

Ensure that the substrate is securely installed and is in accordance with local building regulations. Failure to do so may potentially result in serious harm or damage of property, at the owner's liability and expense.

CHRISTOPHER BOOTS will not be held liable for any damage caused from installation.



Refer to supplied WIRING DIAGRAM.



TECHNICAL INFORMATION										
MODEL	MAX WATTAGE	FIXTURE VOLTAGE (CV)	LAMP TYPE	POWER SUPPLY INPUT VOLTAGE (V AC)	POWER SUPPLY WATTAGE (W)	POWER SUPPLY INPUT CURRENT (typ.)	POWER SUPPLY POWER FACTOR (typ.)	FIXTURE WEIGHT (KG)	NO. SPHERES	EARTH IN CANOPY
OR.2.S	33	24	LED STRIP	127 @ 60Hz	60	0.8A/127VAC	PF≥0.97/127VAC	15	7	YES
				220 @ 60Hz		0.4A/230VAC	PF≥0.95/220VAC			
OR.2.M	53	24	LED STRIP	127 @ 60Hz	100	1.2A/127VAC	PF≥0.98/127VAC	25	12	YES
				220 @ 60Hz		0.55A/230VAC	PF≥0.95/220VAC			
OR.2.L	73	24	LED STRIP	127 @ 60Hz	100	1.2A/127VAC	PF≥0.98/127VAC	35	17	YES
				220 @ 60Hz		0.55A/230VAC	PF≥0.95/220VAC			

**1** Use setout below to mark suspension locations. POWER is located at end suspension point.

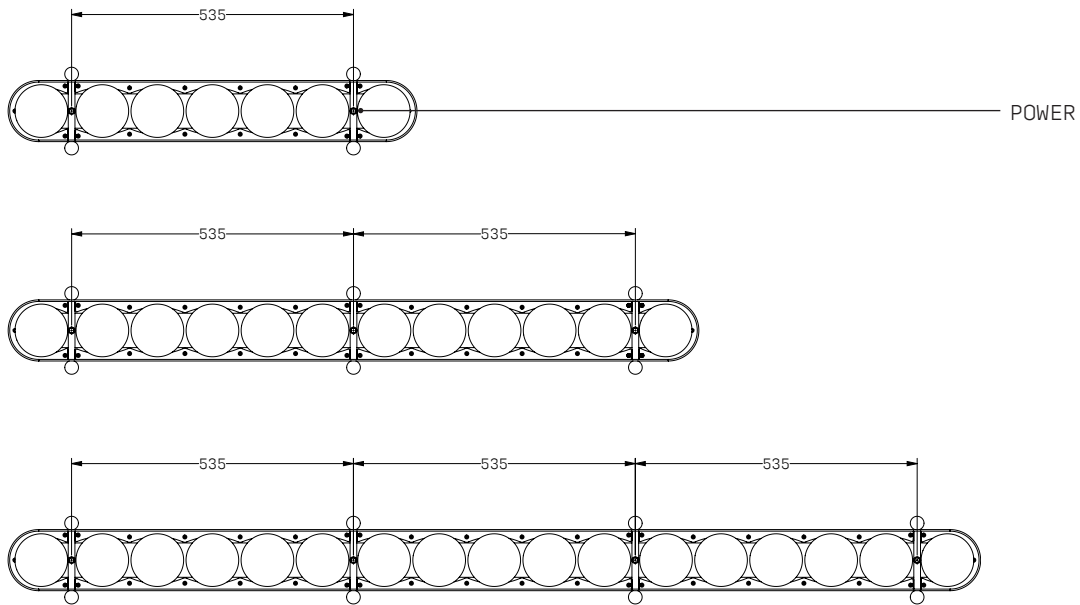

- 2 — Wearing gloves, unpack the 24V DC POWER CABLE & SUSPENSION WIRES attached to the PENDANT.  
Next, unpack the supplied CEILING CANOPY (Illustrations may differ to supplied canopy).  
Do not unwrap the PENDANT, in order to prevent any damage that may occur during installation.
  
- 3 — Feed 24V POWER CABLE through SUSPENSION ROD. Attach all SUSPENSION RODS to T-JOINS using provided ALL-THREAD.

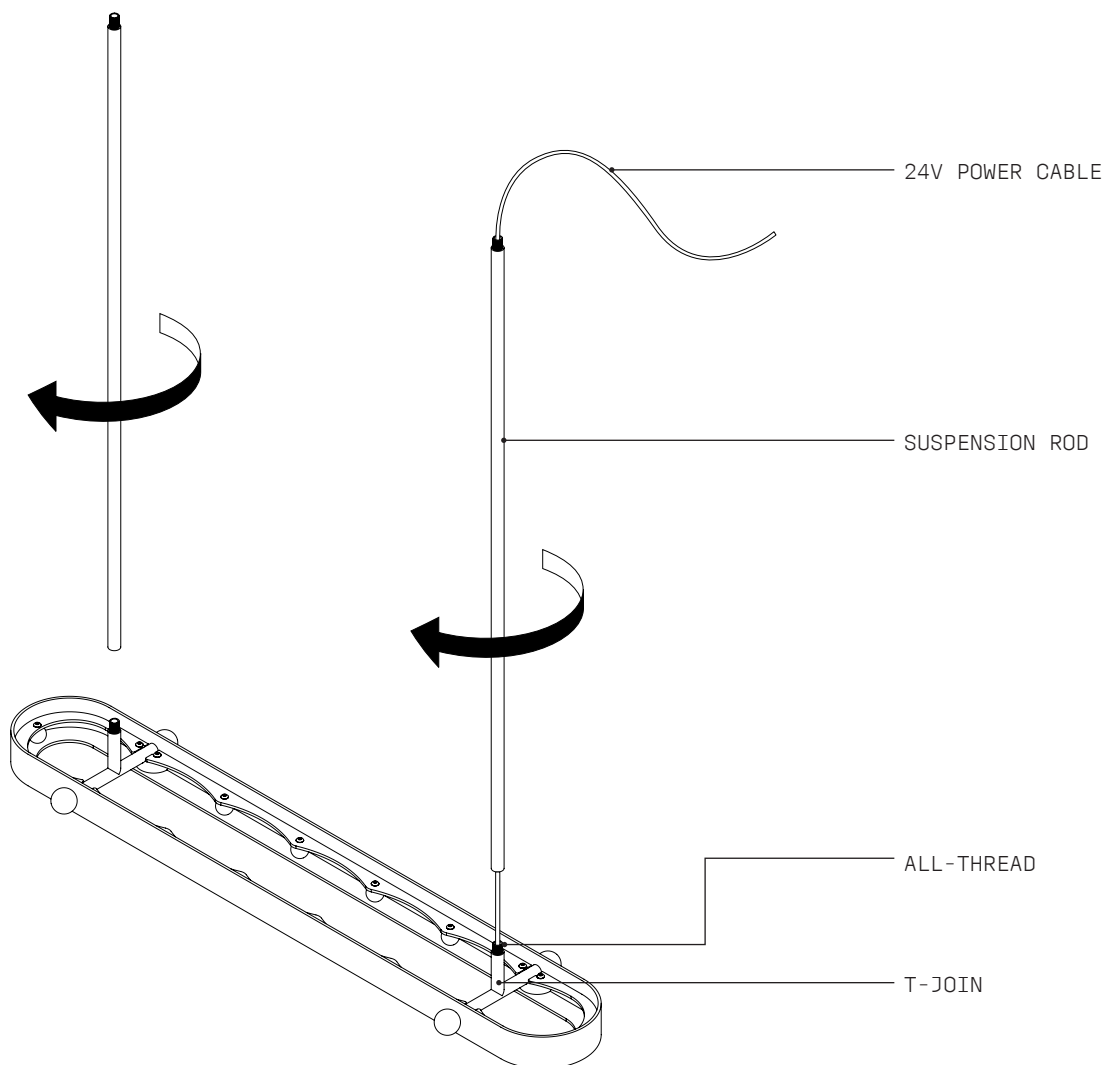

4 — Ensure that the PENDANT is the right way up as per diagram. Feed the 24V DC POWER CABLE and SUSPENSION ROD through their corresponding positions in the escutcheon and the pendant suspension block, as per supplied CANOPY INSTALLATION GUIDE.

5 — Connect the 24V DC POWER CABLE from the PENDANT to supplied POWER SUPPLY UNIT.  
Refer to supplied WIRING DIAGRAM →



6 — Refer to the CANOPY INSTALLATION GUIDE to correctly install all canopy components.

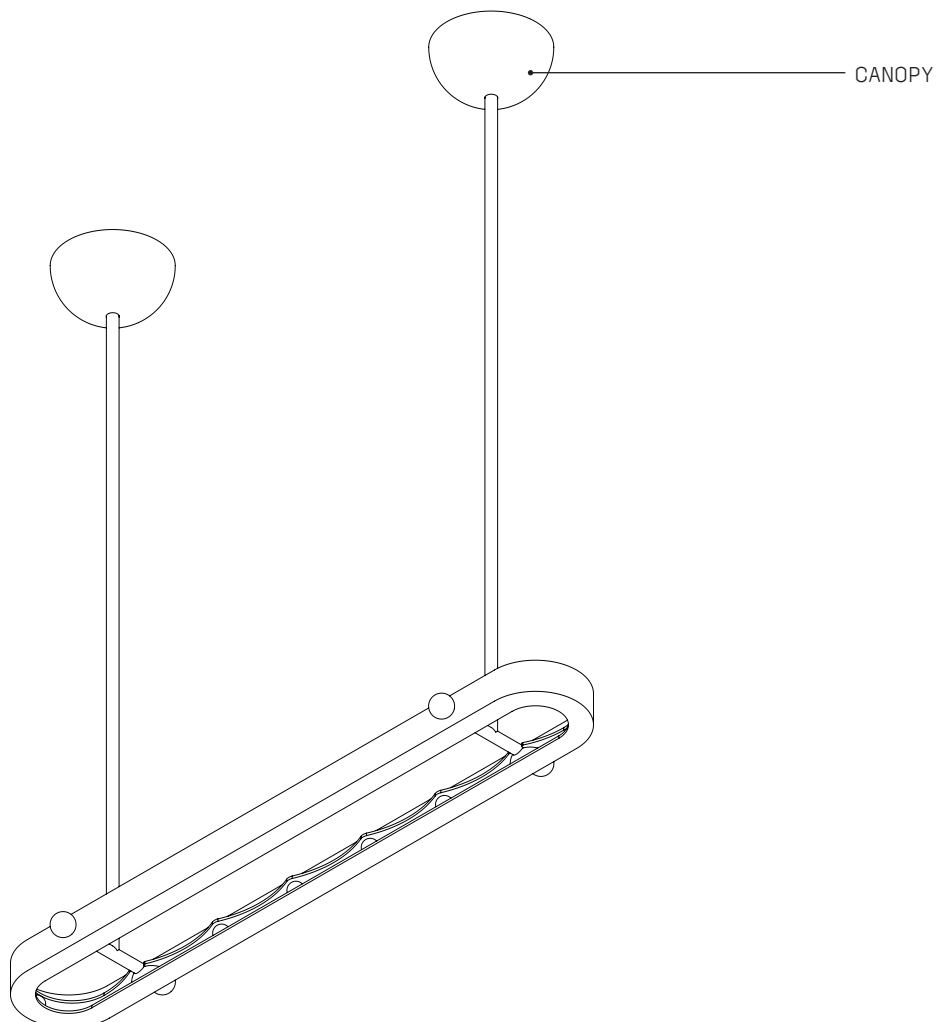



- 7 — Unpack the QUARTZ CRYSTAL SPHERES straight from the box onto the shelves of the pendant ring. Remove protective material on pendant, place 1st sphere at the end of the pendant, and continue in order until all are in position.

If initial crystal selection does not fit as desired, they can be rearranged.

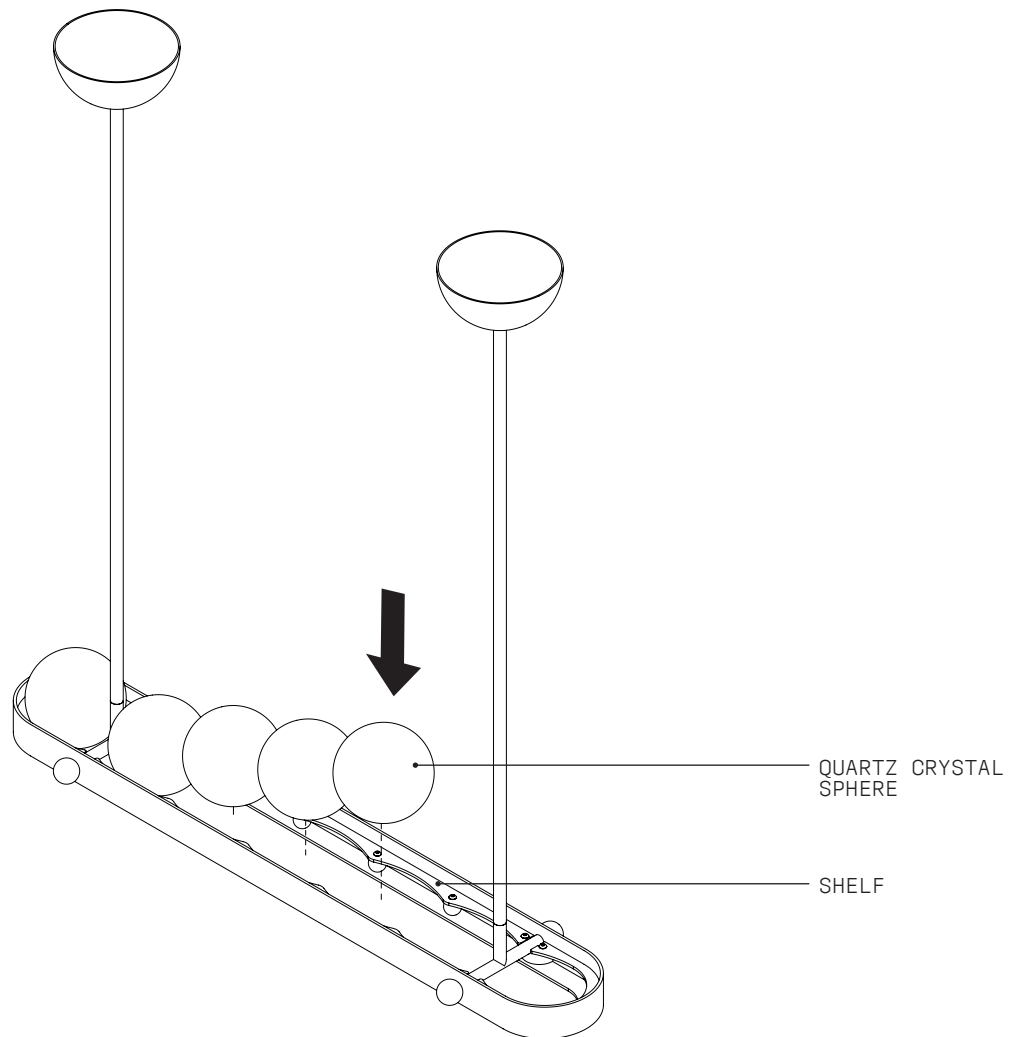

- 8 — Conduct a final visual assessment of the fixture to ensure all parts have been properly fitted and secured. Once satisfied that everything is in working order, remove all remaining protective material which will now complete the installation process.

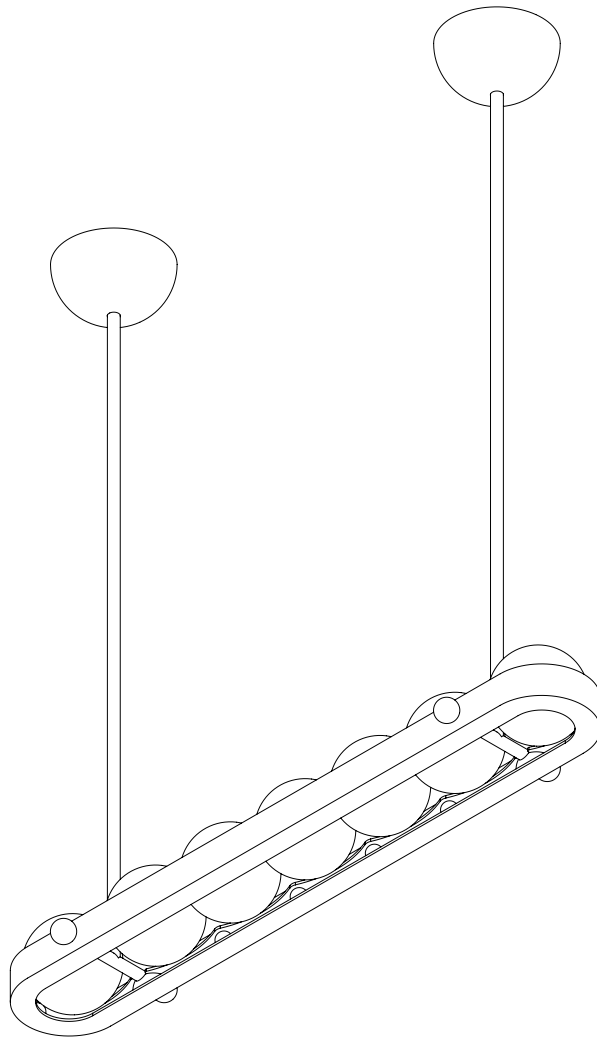

FINISH

The OURANOS PENDANT is for indoor use only and operable to a maximum ambient temperature of 60° celsius. The lamping of this luminaire, is a non-user replaceable source and must only be replaced by CHRISTOPHER BOOTS, an appointed agent and/or qualified professional of CHRISTOPHER BOOTS. Should your pendant require relamping, please contact CHRISTOPHER BOOTS by sending an email to [sales@christopherboots.com](mailto:sales@christopherboots.com) to make the necessary arrangements.



THE LIGHT SOURCE CONTAINED IN THIS LUMINAIRE SHALL ONLY BE REPLACED BY THE MANUFACTURER OR THEIR REPRESENTATIVE AGENT OR A SIMILAR QUALIFIED PERSON

#### CARE INSTRUCTIONS:

OURANOS is a solid fixture that will require very little maintenance over the years, however changes in appearance of hand applied finishes or unlacquered finishes will vary as these (finishes) are designed to age in appearance. If your OURANOS is treated with care, it will shine brightly for many years to come. We recommend some general tips to help keep it shining its brightest:

- Remove dust by simply running an electrostatic duster or dry cloth every few weeks over all exposed surfaces.
- Under no circumstances should the fixture be cleaned with any type of liquids/detergents or solvents.
- If more than dusting is required, please contact us at:  
[sales@christopherboots.com](mailto:sales@christopherboots.com)
- We recommend the use of micro fibre cloths.

## WARRANTY

1. CHRISTOPHER BOOTS offers a 36 month / 3 year warranty from date of receipt of balance payment on all light fittings supplied (not installation) against mechanical defects.
2. CHRISTOPHER BOOTS will repair or replace defective components or product within this warranty period.
3. Warranty for componentry includes:
4. LED lamps and strips: 3 years / 36 months after receipt.
5. LED POWER SUPPLYs 60w: 3 years / 36 months after receipt.
6. LED POWER SUPPLYs 100w + 150w: 5 years / 60 months after receipt.
7. If unsure, please contact sales@christopherboots.com

### Christopher Boots will not be held responsible for the following:

1. Damage caused by improper cleaning solutions or methods.
2. Damage caused by improper installation or assembly by customer or customer's agent.
3. Damage caused by improper use of LED:
4. Damage caused by exposure to weather or improper environment – client to check IP rating prior to purchase.
5. Changes in appearance of hand applied finishes or unlacquered finishes.  
\*Please note that these finishes are designed to age in appearance.
6. Any costs of installation, removal, or re-installation.
7. Restoration, repair work & any parts purchased separately from supplied light fixtures.
8. Damage caused during shipping – all items are packed specifically for global transport.

## DAMAGES

1. Damages must be documented and reported within 7 business days of receipt.
2. Photo evidence will be required upon reporting of damage claim.
3. CHRISTOPHER BOOTS is not responsible for repair or replacement of damages reported after this time.
4. If damage has occurred in shipping – all packaging must be retained by receiver. Failure to do so may invalidate any claim.

## RETURNS

1. Because of the hand-made nature of our product, we are not able to offer returns.
2. Warranty claims, however will require client to cover shipping enroute back for repair

#### A. DEFINITIONS

In this warranty Australian Consumer Law means the Australian consumer law set out in Schedule 2 to the Competition and Consumer Act 2010.

Goods means the product or equipment that was purchased in Australia and listed in the Applicable Product Ranges below.

Manufacturer, We or Us means:  
CHRISTOPHER BOOTS Pty Ltd  
ABN 20 161 794 574

Supplier means the authorized distributor or the licensed electrical contractor that sold you the Goods.

You means you, the original end-user purchaser of the Goods.

#### B. WARRANTY PERIOD AND DETAILS

The products detailed above are covered by a warranty against manufacturing faults and defects, provided that:

The product is properly installed, and installation is consistent with the manufacturer's instructions, and is installed by suitably trained and qualified installer. The product is not subjected to any unauthorised modifications.

The product is only used for the purpose of decorative illumination, in line with its designated purpose.

The product use is in normal conditions.

Any faults or defects attributable to the misuse, abuse, accident or non-observance of the manufacturer's instructions on the part of the user are specifically excluded.

#### C. EXTENT OF THE WARRANTY

GOODS that prove defective within the Warranty Period by reason or improper workmanship or faulty material, we may, at our own discretion, either repair or replace the GOODS without charge.

This warranty does not cover any cost related to removal, shipping to or from the return point, or reinstallation of the replace or repair item.

Any parts of the GOODS replaced during repairs or any product replaced remain the property of CHRISTOPHER BOOTS Pty Ltd.

In the event of the GOODS being replaced during the WARRANTY PERIOD, the warranty on the replacement GOODS will expire on the same date as the WARRANTY PERIOD of the original GOODS they are replacing.

#### D. APPLICABLE DATE/COMMENCEMENT OF WARRANTY

This warranty commences from the date of purchase from the point of purchase from CHRISTOPHER BOOTS Pty Ltd. The details of the point of purchase, as well as all contact information for warranty claims and queries, are detailed below;

CHRISTOPHER BOOTS Pty Ltd.  
369 Gore St. Fitzroy, Vic. Australia 3065  
Ph: +61 3 9417 6501  
Email: sales@christopherboots.com

#### E. CLAIM PROCESS

The customer claim process is as follows; The customer can make a claim, or enquire about the claim process, by contacting the company as detailed above.

The customer must provide a proof of purchase from the SUPPLIER.

Before returning any goods for a warranty claim, the customer must obtain authorization and a Goods Return Authorisation (GRA) notice. The customer, at their own expense, then forwards the goods, clearly marked with the GRA notice and with provision for return freight, to CHRISTOPHER BOOTS Pty Ltd (see above).

Upon receipt of the goods, CHRISTOPHER BOOTS Pty Ltd will review the claim, and proof of purchase.

If accepted as a valid warranty claim within the terms as described in this document, CHRISTOPHER BOOTS Pty Ltd will either make suitable repairs or provide an equivalent replacement product.

If the claim is rejected, the customer will be provided with a full explanation, and if requested, the goods will be returned.

#### IMPORTANT:

Our goods come with guarantees that cannot be excluded under the Australian Consumer Law. You are entitled to a replacement or refund for a major failure and for compensation for any other reasonably foreseeable loss or damage. You are also entitled to have the goods repaired or replaced if the goods fail to be of acceptable quality and the failure does not amount to a major failure.

# OURANOS III PENDANT

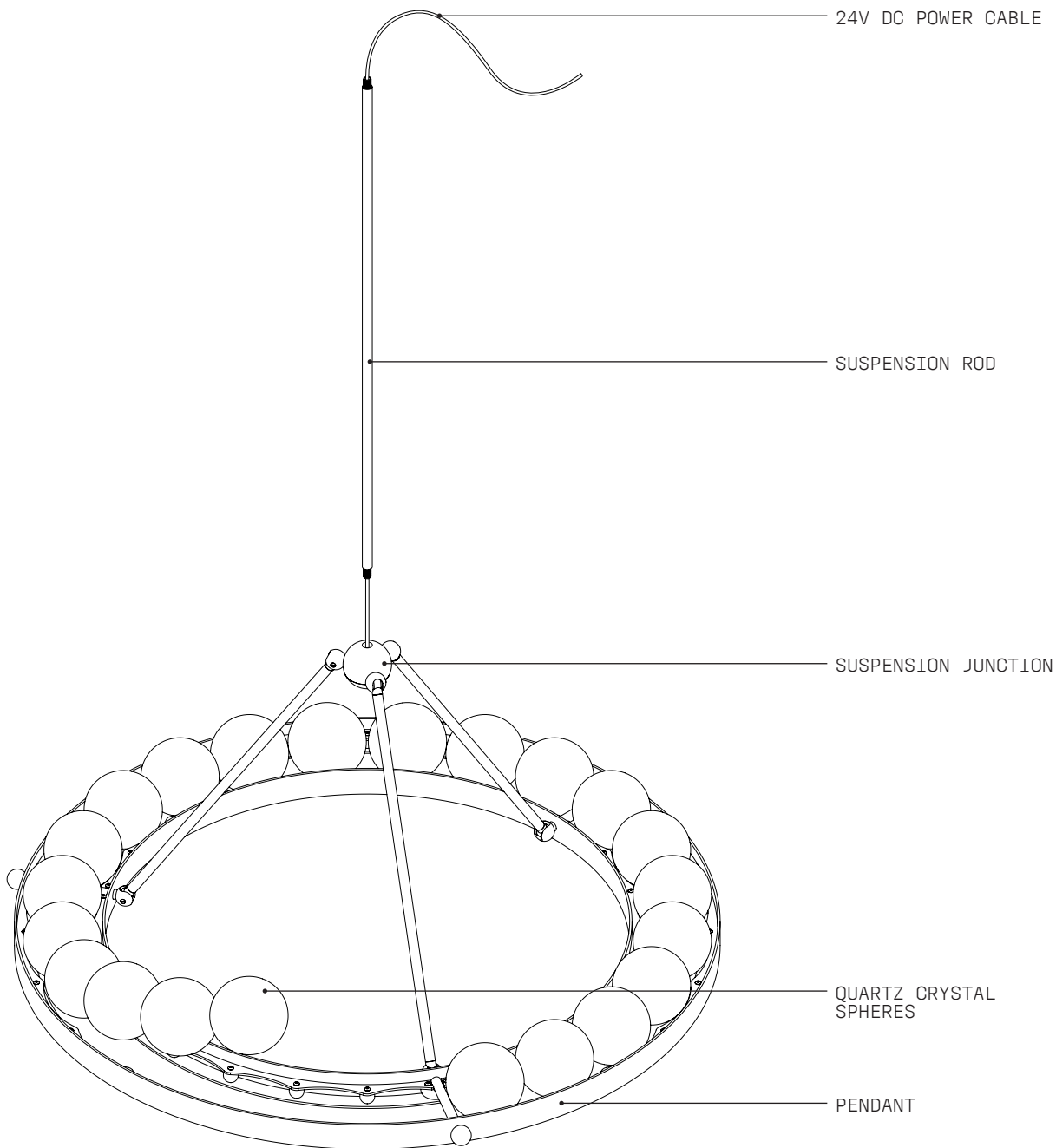



## WARNING: SHOCK HAZARD

May result in serious injury or death.  
ENSURE POWER IS OFF before commencing any work.



## WARNING: ELECTRICAL

ALL ELECTRICAL connections must be made by a qualified electrician in accordance with the regulations and codes governing the area for which the CHRISTOPHER BOOTS Fixture is intended to be installed in. Failure to do so may result in serious harm or damage to property and life, at the owner's liability and expense.

CHRISTOPHER BOOTS will not be held liable for any damage caused from installation.



## WARNING: STRUCTURAL

Ensure that the substrate is securely installed and is in accordance with local building regulations. Failure to do so may potentially result in serious harm or damage of property, at the owner's liability and expense.

CHRISTOPHER BOOTS will not be held liable for any damage caused from installation.



Refer to supplied WIRING DIAGRAM.



- 1 Wearing gloves, unpack the 24V DC POWER CABLE & SUSPENSION WIRES attached to the PENDANT.  
Next unpack the supplied CEILING CANOPY (Illustrations may differ to supplied canopy).  
Do not unwrap the PENDANT, in order to prevent any damage that may occur during installation.
  
- 2 Prop up JUNCTION & SUSPENSION ROD and connect ELBOW using supplied M4 BOLT.

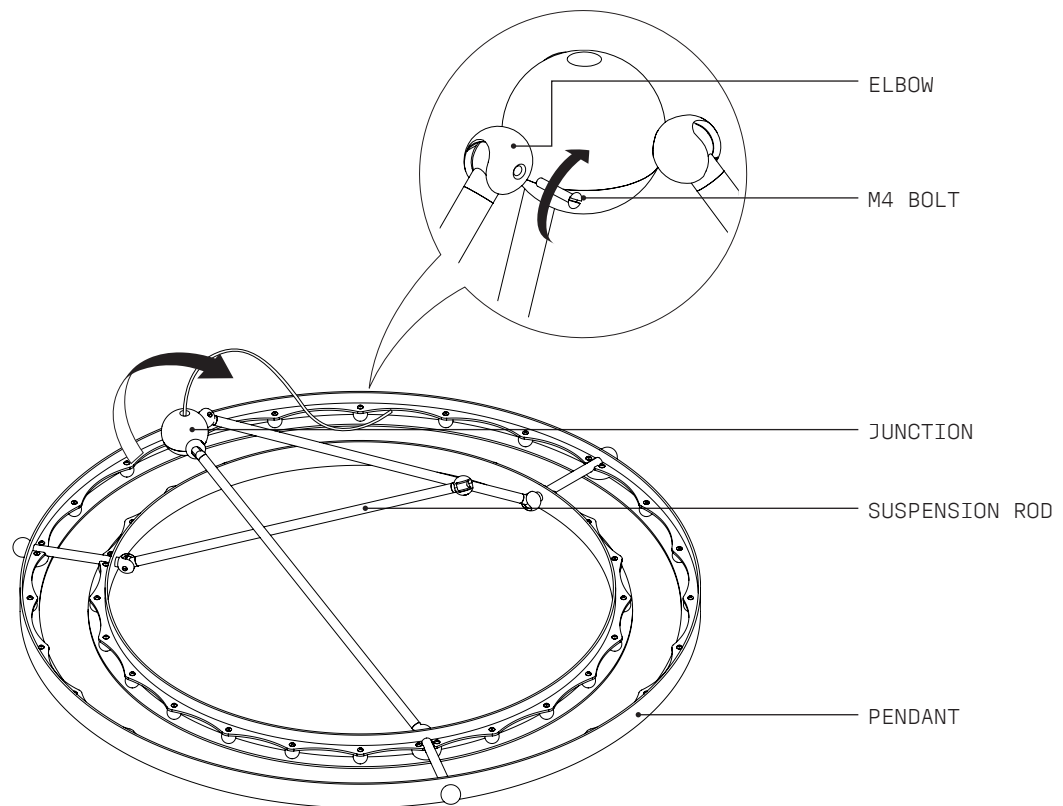



- 3 — Twist and remove JUNCTION COVER and thread SUSPENSION ROD on to JUNCTION BODY using ALL-THREAD. Once attached, pass POWER CABLE through all components and thread on M10 NUT & WASHER.  
Re-attach JUNCTION COVER and ensure all fixings inside junction are tight.

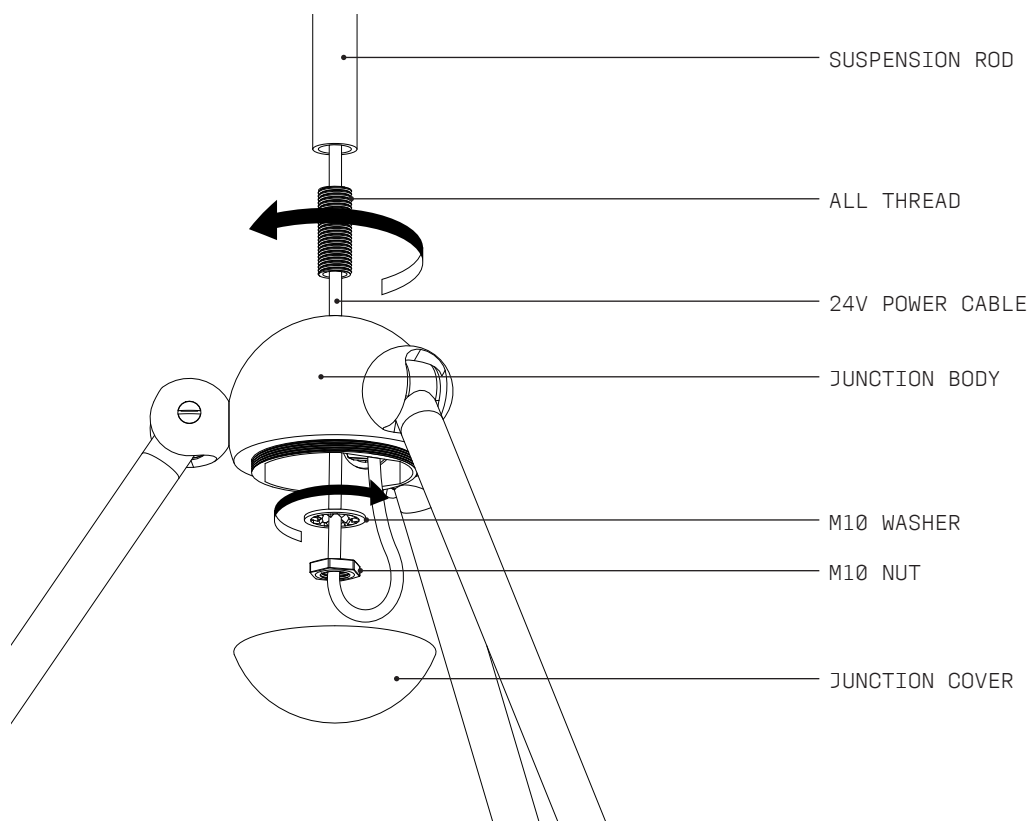

- 4 — Ensure that the PENDANT is the right way up as per diagram. Feed the 24V DC POWER CABLE and SUSPENSION ROD through their corresponding positions in the escutcheon and the pendant suspension block, as per supplied CANOPY INSTALLATION GUIDE.

- 5 Connect the 24V DC POWER CABLE from the PENDANT to supplied POWER SUPPLY UNIT.  
Refer to supplied WIRING DIAGRAM. →



- 6 Refer to the CANOPY INSTALLATION GUIDE to correctly install all canopy components.

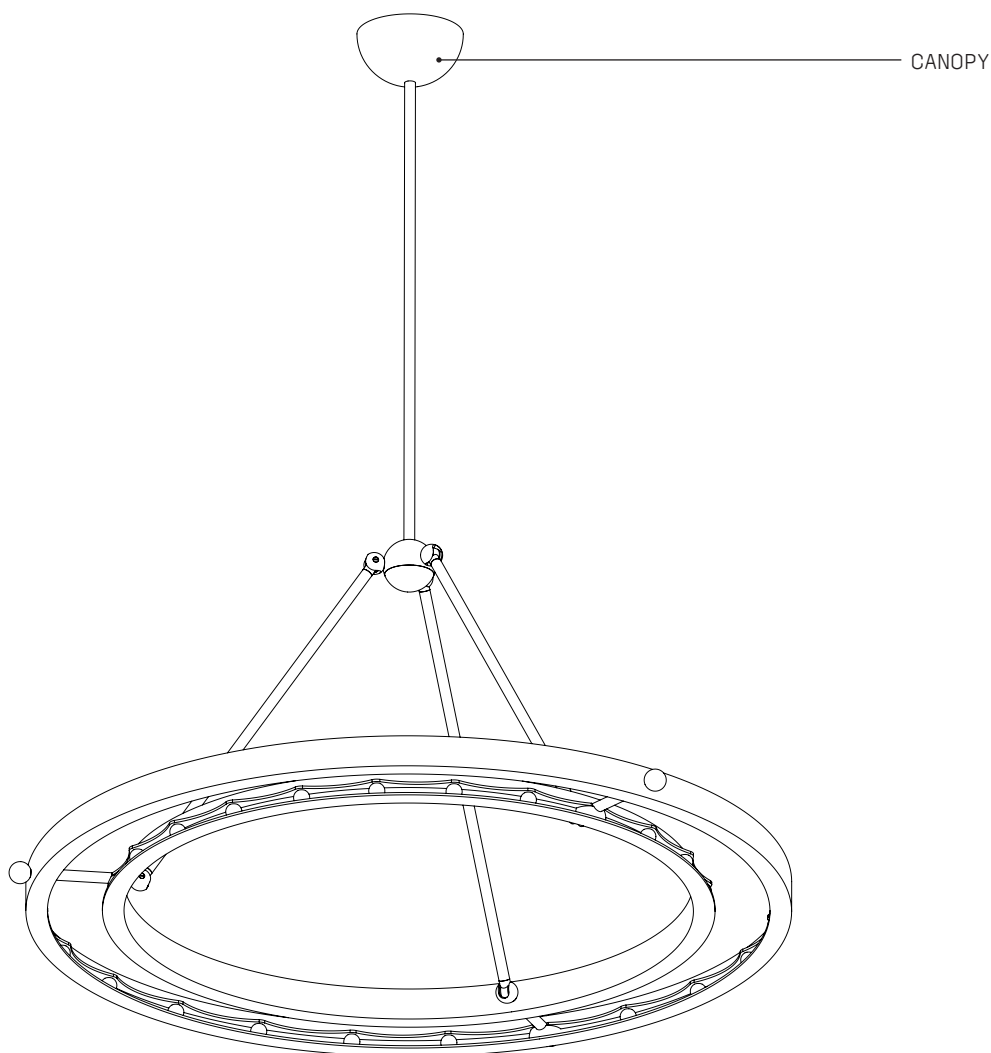

- 7 — Unpack the QUARTZ CRYSTAL SPHERES straight from the box onto the shelves of the pendant ring. Begin by placing one QUARTZ CRYSTAL SPHERE on one side of each SUSPENSION POINT. Continue placing the rest of the spheres until all are in position. If initial crystal selection does not fit as desired, they can be rearranged.

Note: Spread the weight evenly across the pendant by placing spheres on opposite sides of the ring.

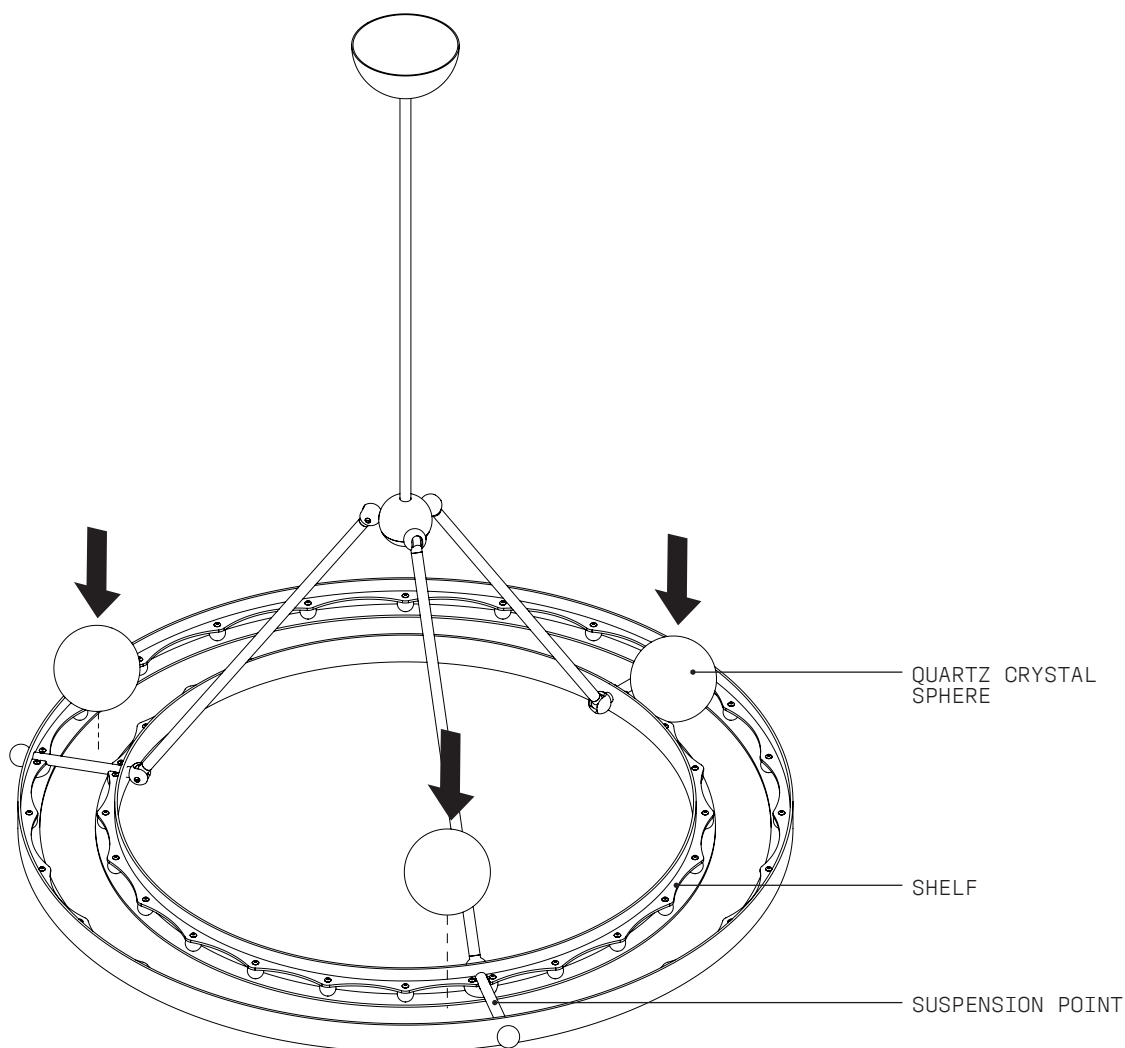

- 8 — Conduct a final visual assessment of the fixture to ensure all parts have been properly fitted and secured. Once satisfied that everything is in working order, remove all remaining protective material which will now complete the installation process.

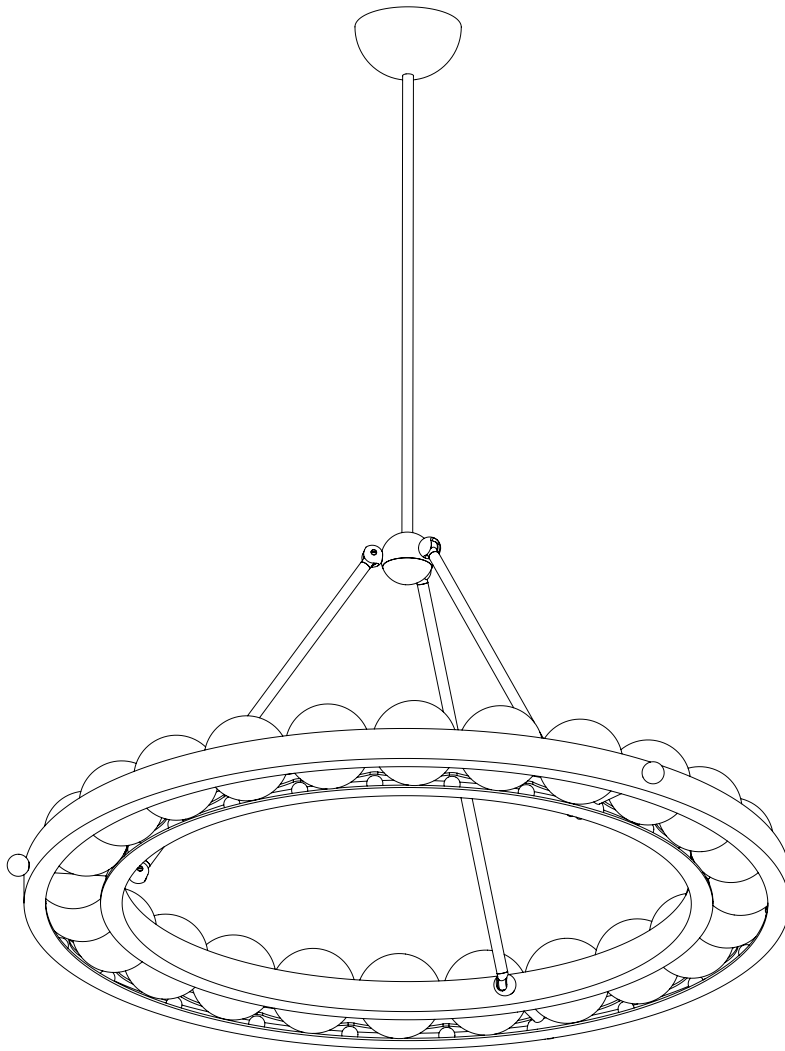

FINISH

The OURANOS PENDANT is for indoor use only and operable to a maximum ambient temperature of 60° celsius. The lamping of this luminaire, is a non-user replaceable source and must only be replaced by CHRISTOPHER BOOTS, an appointed agent and/or qualified professional of CHRISTOPHER BOOTS. Should your pendant require relamping, please contact CHRISTOPHER BOOTS by sending an email to [sales@christopherboots.com](mailto:sales@christopherboots.com) to make the necessary arrangements.



THE LIGHT SOURCE CONTAINED IN THIS LUMINAIRE SHALL ONLY BE REPLACED BY THE MANUFACTURER OR THEIR REPRESENTATIVE AGENT OR A SIMILAR QUALIFIED PERSON

#### CARE INSTRUCTIONS:

OURANOS is a solid fixture that will require very little maintenance over the years, however changes in appearance of hand applied finishes or unlacquered finishes will vary as these (finishes) are designed to age in appearance. If your OURANOS is treated with care, it will shine brightly for many years to come. We recommend some general tips to help keep it shining its brightest:

- Remove dust by simply running an electrostatic duster or dry cloth every few weeks over all exposed surfaces.
- Under no circumstances should the fixture be cleaned with any type of liquids/detergents or solvents.
- If more than dusting is required, please contact us at:  
[sales@christopherboots.com](mailto:sales@christopherboots.com)
- We recommend the use of micro fibre cloths.

## WARRANTY

1. CHRISTOPHER BOOTS offers a 36 month / 3 year warranty from date of receipt of balance payment on all light fittings supplied (not installation) against mechanical defects.
2. CHRISTOPHER BOOTS will repair or replace defective components or product within this warranty period.
3. Warranty for componentry includes:
4. LED lamps and strips: 3 years / 36 months after receipt.
5. LED POWER SUPPLYs 60w: 3 years / 36 months after receipt.
6. LED POWER SUPPLYs 100w + 150w: 5 years / 60 months after receipt.
7. If unsure, please contact sales@christopherboots.com

### Christopher Boots will not be held responsible for the following:

1. Damage caused by improper cleaning solutions or methods.
2. Damage caused by improper installation or assembly by customer or customer's agent.
3. Damage caused by improper use of LED:
4. Damage caused by exposure to weather or improper environment – client to check IP rating prior to purchase.
5. Changes in appearance of hand applied finishes or unlacquered finishes.  
\*Please note that these finishes are designed to age in appearance.
6. Any costs of installation, removal, or re-installation.
7. Restoration, repair work & any parts purchased separately from supplied light fixtures.
8. Damage caused during shipping – all items are packed specifically for global transport.

## DAMAGES

1. Damages must be documented and reported within 7 business days of receipt.
2. Photo evidence will be required upon reporting of damage claim.
3. CHRISTOPHER BOOTS is not responsible for repair or replacement of damages reported after this time.
4. If damage has occurred in shipping – all packaging must be retained by receiver. Failure to do so may invalidate any claim.

## RETURNS

1. Because of the hand-made nature of our product, we are not able to offer returns.
2. Warranty claims, however will require client to cover shipping enroute back for repair

#### A. DEFINITIONS

In this warranty Australian Consumer Law means the Australian consumer law set out in Schedule 2 to the Competition and Consumer Act 2010.

Goods means the product or equipment that was purchased in Australia and listed in the Applicable Product Ranges below.

Manufacturer, We or Us means:  
CHRISTOPHER BOOTS Pty Ltd  
ABN 20 161 794 574

Supplier means the authorized distributor or the licensed electrical contractor that sold you the Goods.

You means you, the original end-user purchaser of the Goods.

#### B. WARRANTY PERIOD AND DETAILS

The products detailed above are covered by a warranty against manufacturing faults and defects, provided that:

The product is properly installed, and installation is consistent with the manufacturer's instructions, and is installed by suitably trained and qualified installer. The product is not subjected to any unauthorised modifications.

The product is only used for the purpose of decorative illumination, in line with its designated purpose.

The product use is in normal conditions.

Any faults or defects attributable to the misuse, abuse, accident or non-observance of the manufacturer's instructions on the part of the user are specifically excluded.

#### C. EXTENT OF THE WARRANTY

GOODS that prove defective within the Warranty Period by reason or improper workmanship or faulty material, we may, at our own discretion, either repair or replace the GOODS without charge.

This warranty does not cover any cost related to removal, shipping to or from the return point, or reinstallation of the replace or repair item.

Any parts of the GOODS replaced during repairs or any product replaced remain the property of CHRISTOPHER BOOTS Pty Ltd.

In the event of the GOODS being replaced during the WARRANTY PERIOD, the warranty on the replacement GOODS will expire on the same date as the WARRANTY PERIOD of the original GOODS they are replacing.

#### D. APPLICABLE DATE/COMMENCEMENT OF WARRANTY

This warranty commences from the date of purchase from the point of purchase from CHRISTOPHER BOOTS Pty Ltd. The details of the point of purchase, as well as all contact information for warranty claims and queries, are detailed below;

CHRISTOPHER BOOTS Pty Ltd.  
369 Gore St. Fitzroy, Vic. Australia 3065  
Ph: +61 3 9417 6501  
Email: sales@christopherboots.com

#### E. CLAIM PROCESS

The customer claim process is as follows; The customer can make a claim, or enquire about the claim process, by contacting the company as detailed above.

The customer must provide a proof of purchase from the SUPPLIER.

Before returning any goods for a warranty claim, the customer must obtain authorization and a Goods Return Authorisation (GRA) notice. The customer, at their own expense, then forwards the goods, clearly marked with the GRA notice and with provision for return freight, to CHRISTOPHER BOOTS Pty Ltd (see above).

Upon receipt of the goods, CHRISTOPHER BOOTS Pty Ltd will review the claim, and proof of purchase.

If accepted as a valid warranty claim within the terms as described in this document, CHRISTOPHER BOOTS Pty Ltd will either make suitable repairs or provide an equivalent replacement product.

If the claim is rejected, the customer will be provided with a full explanation, and if requested, the goods will be returned.

#### IMPORTANT:

Our goods come with guarantees that cannot be excluded under the Australian Consumer Law. You are entitled to a replacement or refund for a major failure and for compensation for any other reasonably foreseeable loss or damage. You are also entitled to have the goods repaired or replaced if the goods fail to be of acceptable quality and the failure does not amount to a major failure.