

PETRA

SCONCE

PET.1.3, PET.1.2, PET.1.3

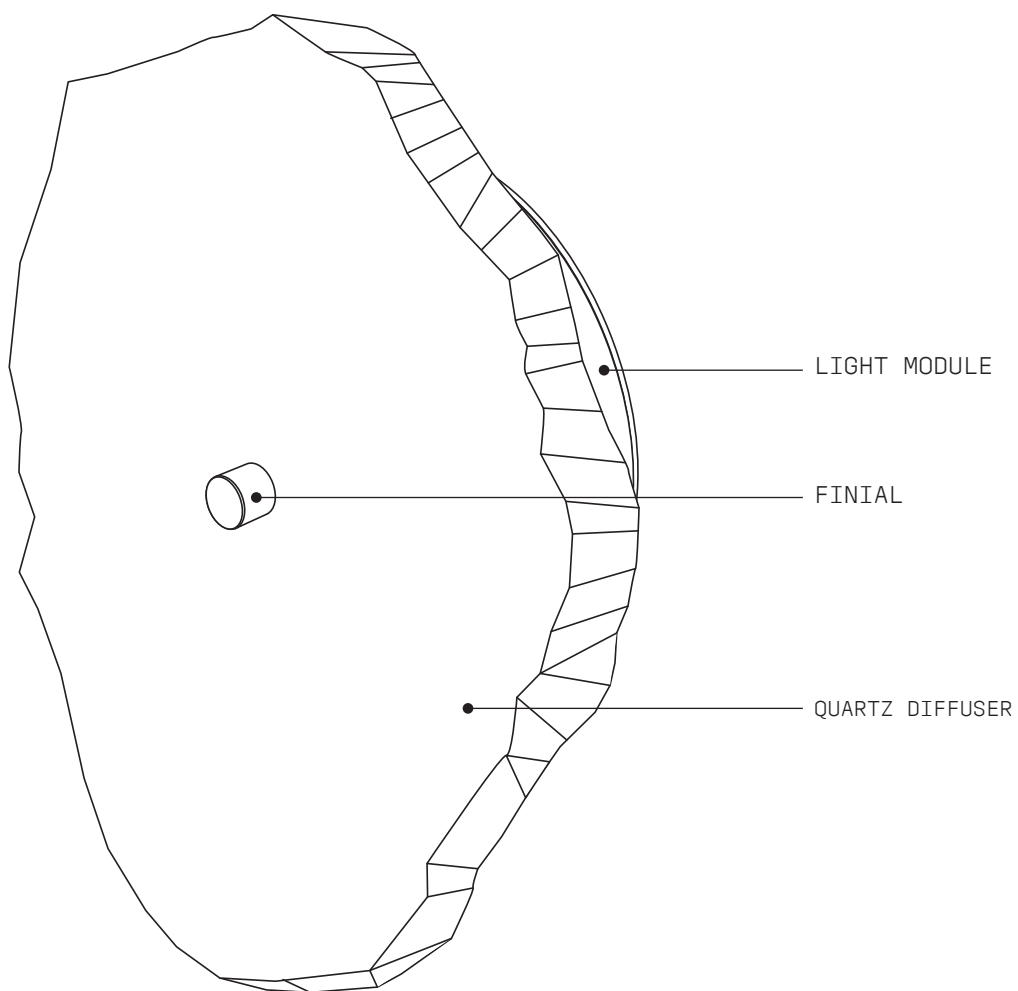



**WARNING:
SHOCK HAZARD**

May result in serious injury or death.
ENSURE POWER IS OFF before commencing any work.



**WARNING:
ELECTRICAL**

ALL ELECTRICAL connections must be made by a qualified electrician in accordance with the regulations and codes governing the area for which the CHRISTOPHER BOOTS Fixture is intended to be installed in. Failure to do so may result in serious harm or damage to property and life, at the owner’s liability and expense.

CHRISTOPHER BOOTS will not be held liable for any damage caused from installation.



**WARNING:
STRUCTURAL**

Ensure that the substrate is securely installed and is in accordance with local building regulations. Failure to do so may potentially result in serious harm or damage of property, at the owner’s liability and expense.

CHRISTOPHER BOOTS will not be held liable for any damage caused from installation.



Refer to supplied WIRING DIAGRAM.

MODEL	WATTAGE	LAMP TYPE	POWER SUPPLY	WEIGHT (KG)
PET.1.1	8	LED	DRIVER: LED Power Supply Unit 60W	3
PET.1.2	9	LED	DRIVER: LED Power Supply Unit 60W	6
PET.1.3	12	LED	DRIVER: LED Power Supply Unit 60W	9

- 1 Wearing gloves, unpack the PETRA MONO SCONCE with care ensuring not to scratch the delicate surface of the LIGHT MODULE
— Separate the LIGHT MODULE from the other components.
To remove the ACRYLIC DIFFUSER, push a small screw driver through the mounting holes at the back of the LIGHT MODULE.

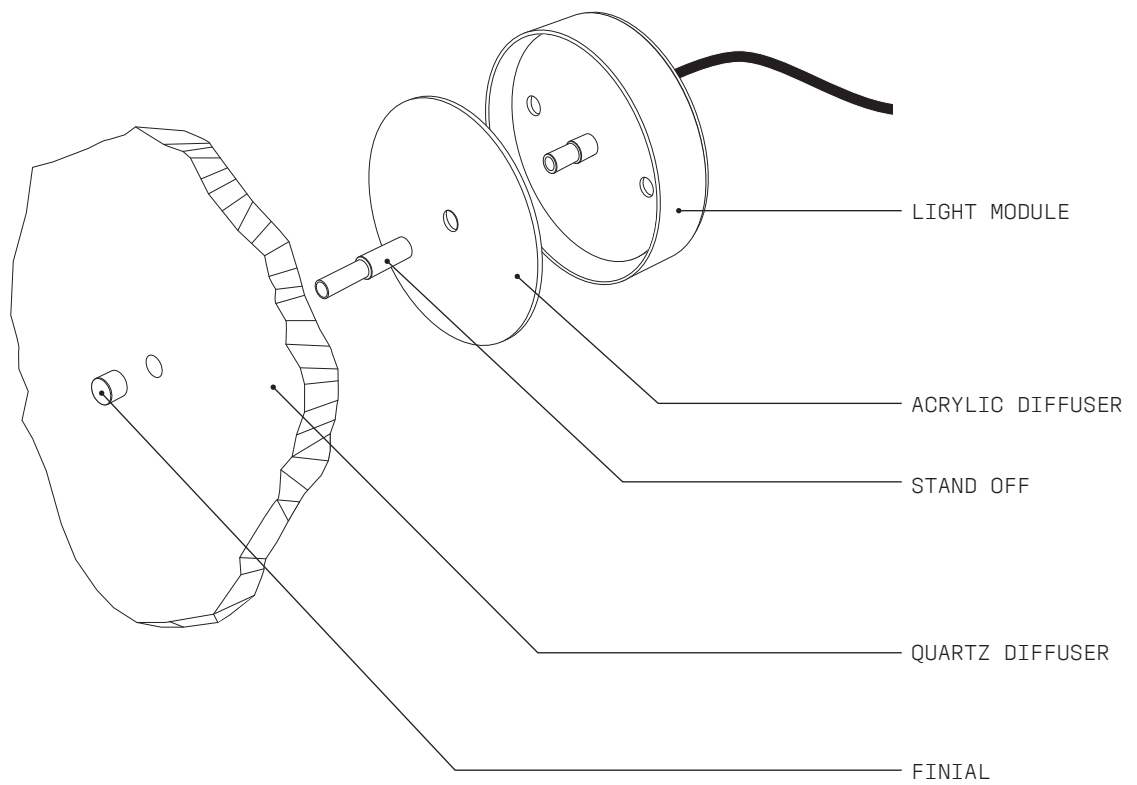

- 2 Remove this page and utilise the diagram below to ensure FIXING PILOT HOLES and POWER EXIT HOLE and in the correct position.

DRILLING TEMPLATE

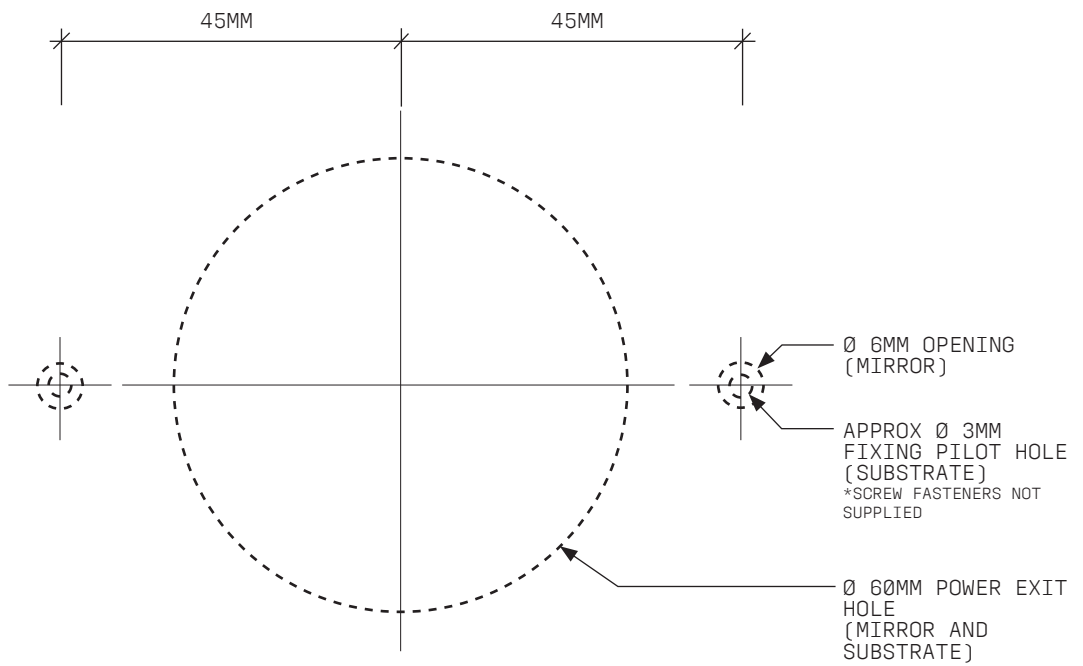

- 3 If installing multiple fixtures refer to the following recommended set out for spacing below.

TWIN SET OUT

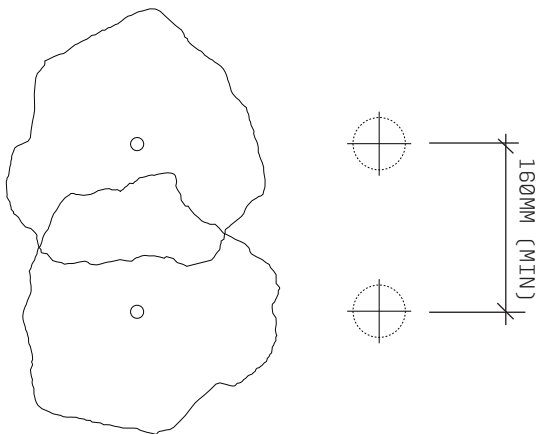

TRIPLE SET OUT

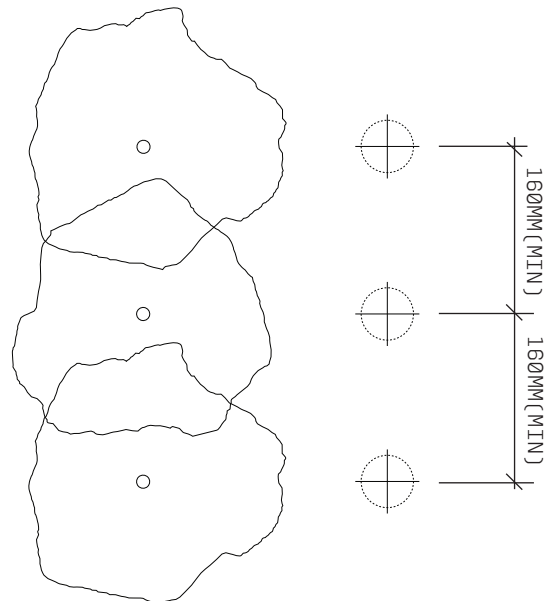

- 4 Prepare the 60mm hole in the mounting surface.

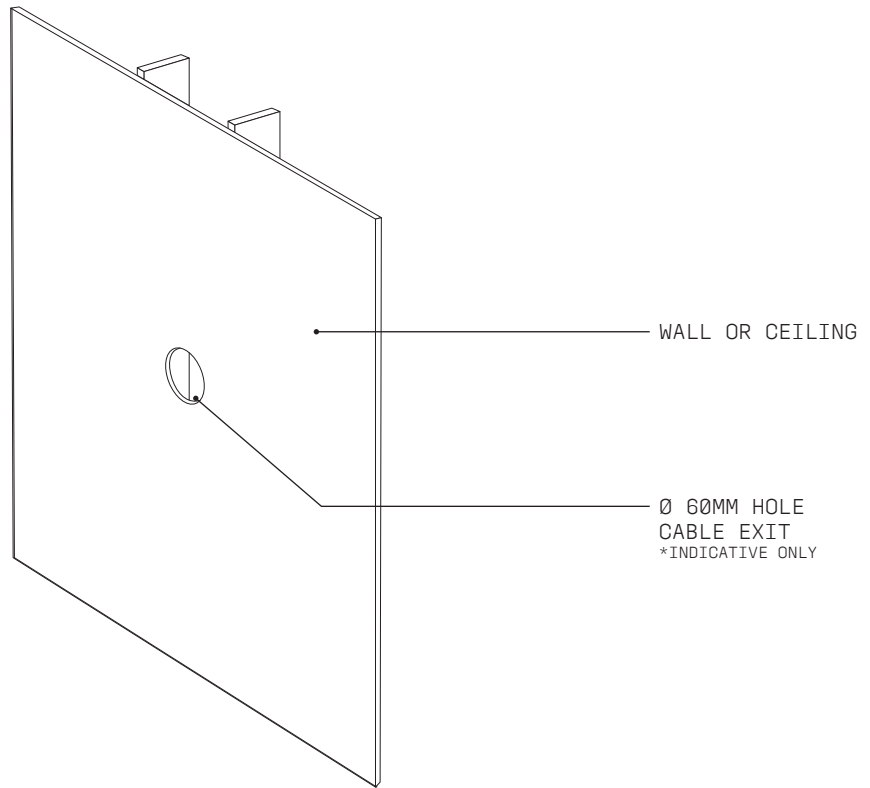

- 5 Installer to provide adequate load-bearing substrate, utilising joists where additional support is required.

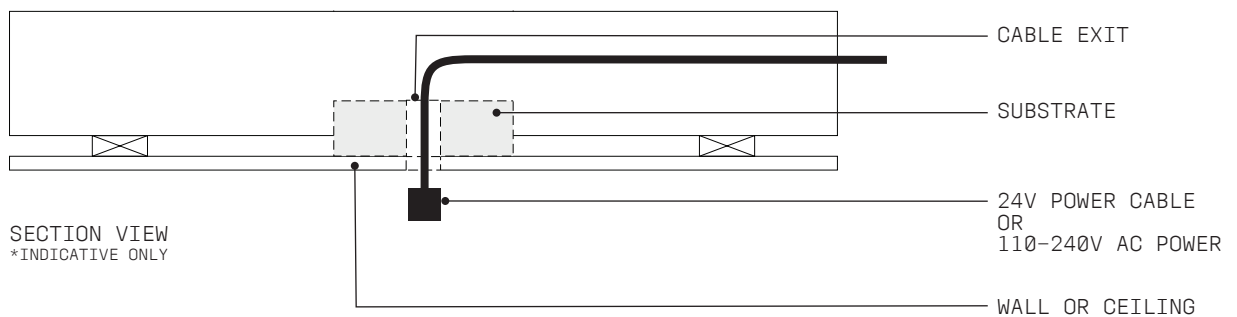

- 6 A. Attach the LIGHT MODULE to Substrate with appropriate fasteners.
- B. Ensure the back plate of the LIGHT MODULE is flat against the mounting surface.
- C. Connect the 110-240V AC Power to the PSU. Refer to supplied wiring diagram. →

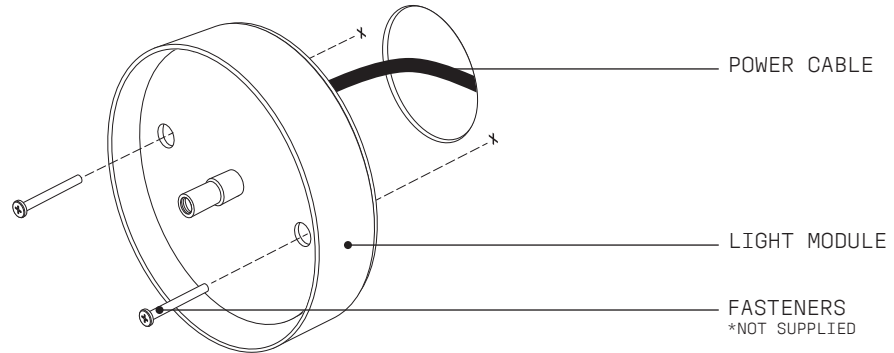

- 7 Place the ACRYLIC DIFFUSER into the LIGHT MODULE so the THREADED ROD protrudes through the central hole.

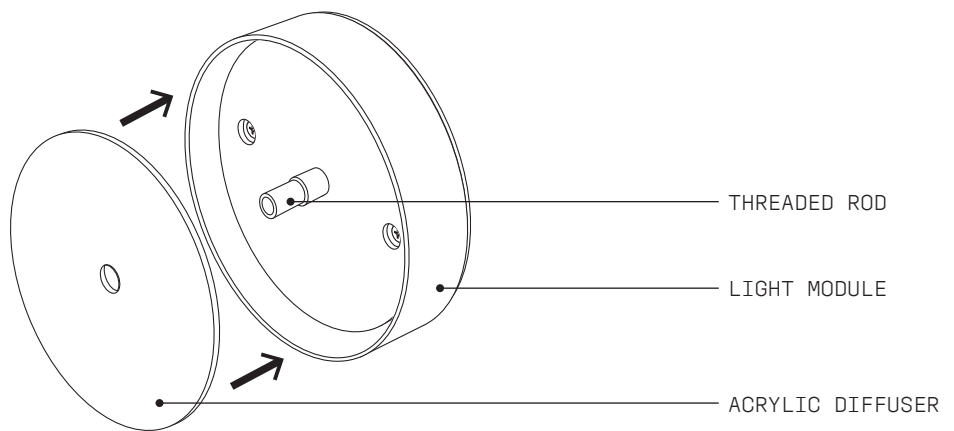

- 8 With the ACRYLIC DIFFUSER in place - position the STAND OFF in line with the threaded rod and tighten clockwise until the diffuser is secured in place. Be careful not to over tighten as this may damage the diffuser.

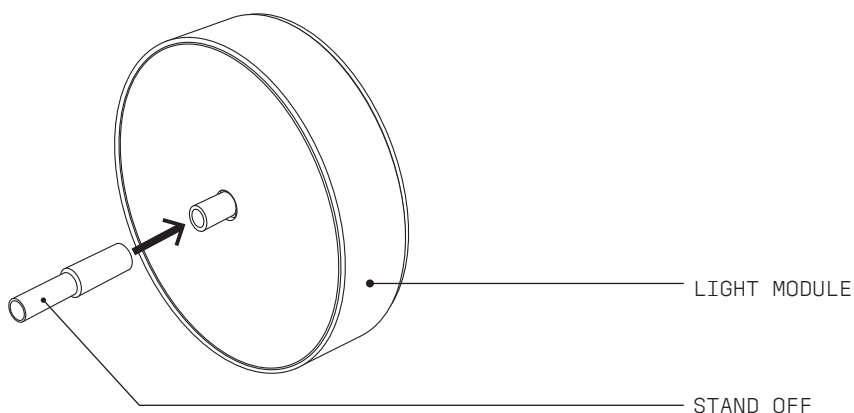

- 9 With the STAND OFF securely in place - carefully position the QUARTZ DIFFUSER over the STAND OFF so that the threaded rod protrudes through the central hole and hold in place

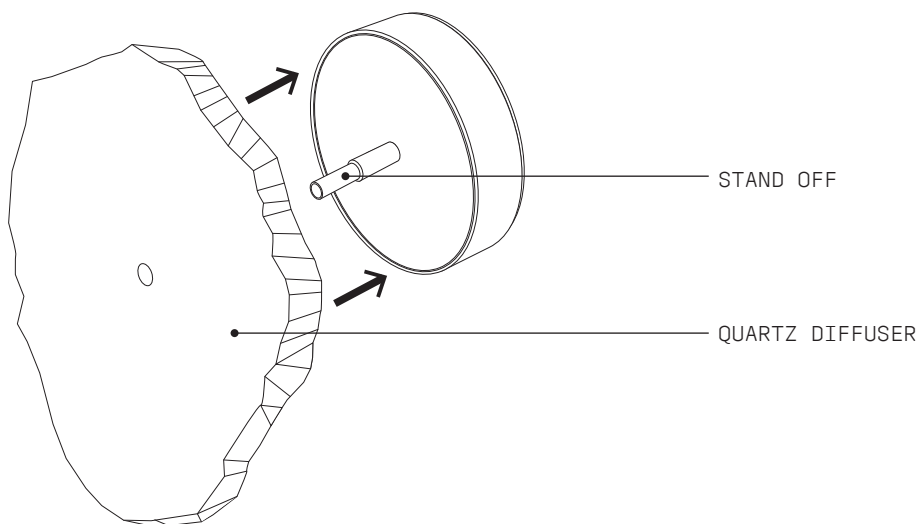

- 10 — Whilst holding the QUARTZ DIFFUSER in place with one hand - position the FINIAL over the threaded rod and tighten until the QUARTZ DIFFUSER is secured in place. Be careful not to over tighten as this may damage the stone.

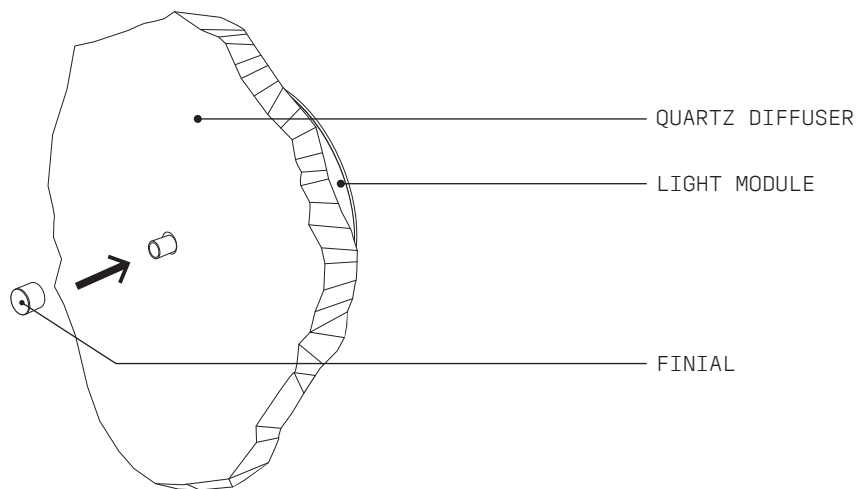

- 11 — Conduct a final visual assessment of fixture to ensure all parts have been properly fitted and secured. Once satisfied that everything is in working order the installation is complete. Please dispose of packaging material thoughtfully.

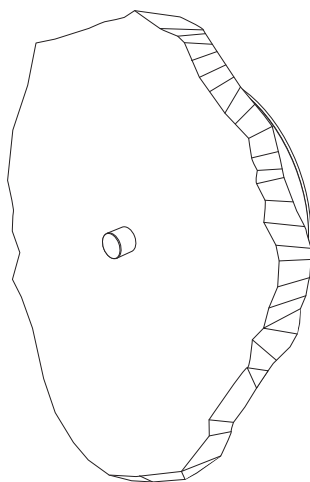

FINISH

The PETRA Sconce is for indoor use only and operable to a maximum ambient temperature of 60° celsius. The lamping of this luminaire, is a non-user replaceable source and must only be replaced by CHRISTOPHER BOOTS, an appointed agent and/or qualified professional of CHRISTOPHER BOOTS. Should your sconce require relamping, please contact CHRISTOPHER BOOTS by sending an email to sales@christopherboots.com to make the necessary arrangements.



THE LIGHT SOURCE CONTAINED IN THIS LUMINAIRE SHALL ONLY BE REPLACED BY THE MANUFACTURER OR THEIR REPRESENTATIVE AGENT OR A SIMILAR QUALIFIED PERSON.

CARE INSTRUCTIONS:

PETRA is a solid fixture that will require very little maintenance over the years, however changes in appearance of hand applied finishes or unlacquered finishes will vary as these (finishes) are designed to age in appearance. If your PETRA is treated with care, it will shine brightly for many years to come. We recommend some general tips to help keep it shining its brightest:

- Remove dust by simply running an electrostatic duster or dry cloth every few weeks over all exposed surfaces.
- Under no circumstances should the fixture be cleaned with any type of liquids/detergents or solvents.
- If more than dusting is required, please contact us at: sales@christopherboots.com
- We recommend the use of micro fibre cloths.

WARRANTY

1. CHRISTOPHER BOOTS offers a 36 month / 3 year warranty from date of receipt of balance payment on all light fittings supplied (not installation) against mechanical defects.
2. CHRISTOPHER BOOTS will repair or replace defective components or product within this warranty period.
3. Warranty for componentry includes:
4. LED lamps and strips: 3 years / 36 months after receipt.
5. LED drivers 60w: 3 years / 36 months after receipt.
6. LED drivers 100w + 150w: 5 years / 60 months after receipt.
7. If unsure, please contact sales@christopherboots.com

Christopher Boots will not be held responsible for the following:

1. Damage caused by improper cleaning solutions or methods.
2. Damage caused by improper installation or assembly by customer or customer's agent.
3. Damage caused by improper use of LED:
4. Damage caused by exposure to weather or improper environment – client to check IP rating prior to purchase.
5. Changes in appearance of hand applied finishes or unlacquered finishes.
*Please note that these finishes are designed to age in appearance.
6. Any costs of installation, removal, or re-installation.
7. Restoration, repair work & any parts purchased separately from supplied light fixtures.
8. Damage caused during shipping – all items are packed specifically for global transport.

DAMAGES

1. Damages must be documented and reported within 7 business days of receipt.
2. Photo evidence will be required upon reporting of damage claim.
3. CHRISTOPHER BOOTS is not responsible for repair or replacement of damages reported after this time.
4. If damage has occurred in shipping – all packaging must be retained by receiver. Failure to do so may invalidate any claim.

RETURNS

1. Because of the hand-made nature of our product, we are not able to offer returns.
2. Warranty claims, however will require client to cover shipping en route back for repair

A. DEFINITIONS

In this warranty Australian Consumer Law means the Australian consumer law set out in Schedule 2 to the Competition and Consumer Act 2010.

Goods means the product or equipment that was purchased in Australia and listed in the Applicable Product Ranges below.

Manufacturer, We or Us means:
CHRISTOPHER BOOTS Pty Ltd
ABN 20 161 794 574

Supplier means the authorized distributor or the licensed electrical contractor that sold you the Goods.

You means you, the original end-user purchaser of the Goods.

B. WARRANTY PERIOD AND DETAILS

The products detailed above are covered by a warranty against manufacturing faults and defects, provided that:

The product is properly installed, and installation is consistent with the manufacturer's instructions, and is installed by suitably trained and qualified installer. The product is not subjected to any unauthorised modifications.

The product is only used for the purpose of decorative illumination, in line with its designated purpose.

The product use is in normal conditions.

Any faults or defects attributable to the misuse, abuse, accident or non-observance of the manufacturer's instructions on the part of the user are specifically excluded.

C. EXTENT OF THE WARRANTY

GOODS that prove defective within the Warranty Period by reason or improper workmanship or faulty material, we may, at our own discretion, either repair or replace the GOODS without charge.

This warranty does not cover any cost related to removal, shipping to or from the return point, or reinstallation of the replace or repair item.

Any parts of the GOODS replaced during repairs or any product replaced remain the property of CHRISTOPHER BOOTS Pty Ltd.

In the event of the GOODS being replaced during the WARRANTY PERIOD, the warranty on the replacement GOODS will expire on the same date as the WARRANTY PERIOD of the original GOODS they are replacing.

D. APPLICABLE DATE/COMMENCEMENT OF WARRANTY

This warranty commences from the date of purchase from the point of purchase from CHRISTOPHER BOOTS Pty Ltd. The details of the point of purchase, as well as all contact information for warranty claims and queries, are detailed below;

CHRISTOPHER BOOTS Pty Ltd.
369 Gore St. Fitzroy, Vic. Australia 3065
Ph: +61 3 9417 6501
Email: sales@christopherboots.com

E. CLAIM PROCESS

The customer claim process is as follows; The customer can make a claim, or enquire about the claim process, by contacting the company as detailed above.

The customer must provide a proof of purchase from the SUPPLIER.

Before returning any goods for a warranty claim, the customer must obtain authorization and a Goods Return Authorisation (GRA) notice. The customer, at their own expense, then forwards the goods, clearly marked with the GRA notice and with provision for return freight, to CHRISTOPHER BOOTS Pty Ltd (see above).

Upon receipt of the goods, CHRISTOPHER BOOTS Pty Ltd will review the claim, and proof of purchase.

If accepted as a valid warranty claim within the terms as described in this document, CHRISTOPHER BOOTS Pty Ltd will either make suitable repairs or provide an equivalent replacement product.

If the claim is rejected, the customer will be provided with a full explanation, and if requested, the goods will be returned.

IMPORTANT:

Our goods come with guarantees that cannot be excluded under the Australian Consumer Law. You are entitled to a replacement or refund for a major failure and for compensation for any other reasonably foreseeable loss or damage. You are also entitled to have the goods repaired or replaced if the goods fail to be of acceptable quality and the failure does not amount to a major failure.

PETRA II 900, 1200, 1500, 1800, 2100, 2400

PENDANT ONLY

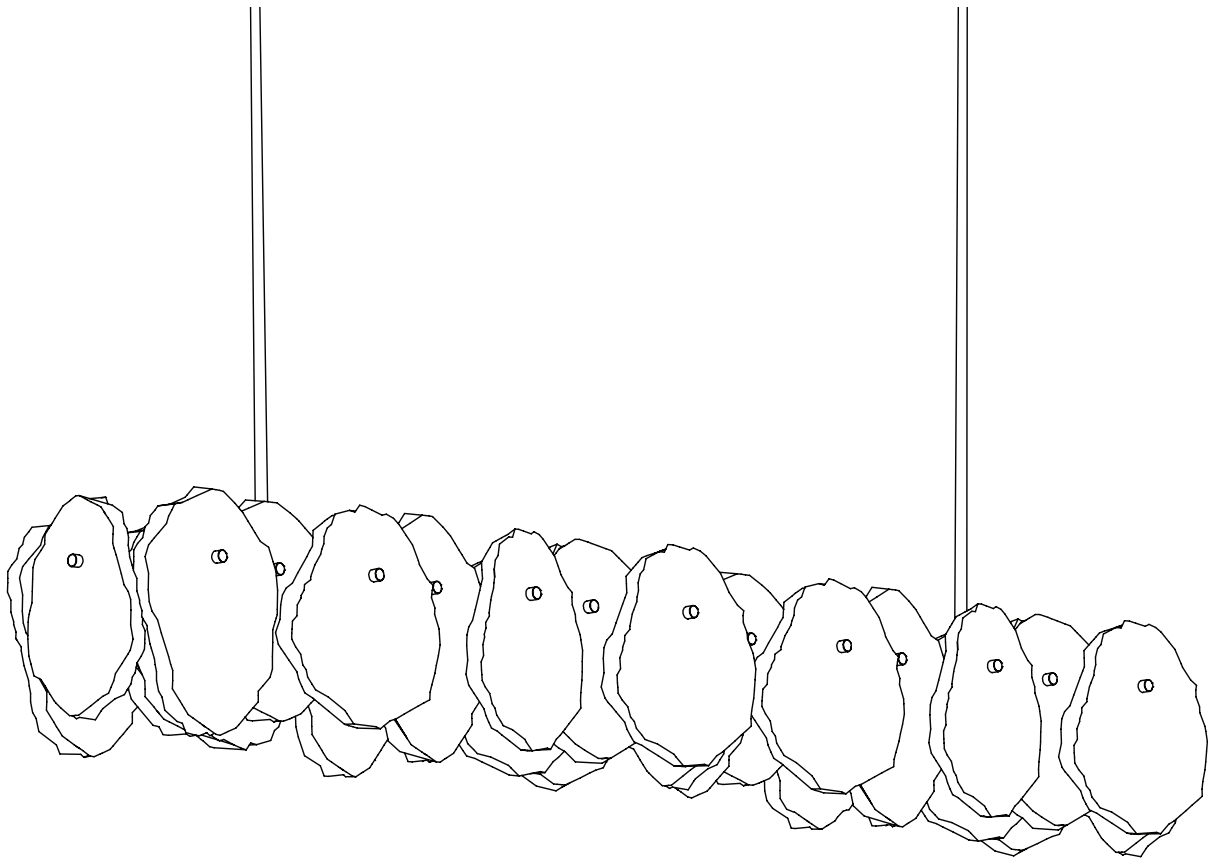



**WARNING:
SHOCK HAZARD**

May result in serious injury or death.
ENSURE POWER IS OFF before commencing any work.



**WARNING:
ELECTRICAL**

ALL ELECTRICAL connections must be made by a qualified electrician in accordance with the regulations and codes governing the area for which the CHRISTOPHER BOOTS Fixture is intended to be installed in. Failure to do so may result in serious harm or damage to property and life, at the owner’s liability and expense.
CHRISTOPHER BOOTS will not be held liable for any damage caused from installation.



**WARNING:
STRUCTURAL**

Ensure that the substrate is securely installed and is in accordance with local building regulations. Failure to do so may potentially result in serious harm or damage of property, at the owner’s liability and expense.
CHRISTOPHER BOOTS will not be held liable for any damage caused from installation.

TECHNICAL INFORMATION									
MODEL	MAX WATTAGE	FIXTURE VOLTAGE (CV)	LAMP TYPE	POWER SUPPLY INPUT VOLTAGE (V AC)	POWER SUPPLY WATTAGE (W)	POWER SUPPLY INPUT CURRENT (typ.)	POWER SUPPLY POWER FACTOR (typ.)	FIXTURE WEIGHT (KG)	EARTH IN CANOPY
PET.2.900	15	24	LED STRIP	100-120 @ 60Hz	60	0.8A/115VAC	PF≥0.97/115VAC	31	YES
				220-240 @ 50Hz		0.4A/230VAC	PF≥0.95/230VAC		
PET.2.1200	21	24	LED STRIP	100-120 @ 60Hz	60	0.8A/115VAC	PF≥0.97/115VAC	39	YES
				220-240 @ 50Hz		0.4A/230VAC	PF≥0.95/230VAC		
PET.2.1500	27	24	LED STRIP	100-120 @ 60Hz	60	0.8A/115VAC	PF≥0.97/115VAC	47	YES
				220-240 @ 50Hz		0.4A/230VAC	PF≥0.95/230VAC		
PET.2.1800	33	24	LED STRIP	100-120 @ 60Hz	60	0.8A/115VAC	PF≥0.97/115VAC	54	YES
				220-240 @ 50Hz		0.4A/230VAC	PF≥0.95/230VAC		
PET.2.2100	38	24	LED STRIP	100-120 @ 60Hz	60	0.8A/115VAC	PF≥0.97/115VAC	62	YES
				220-240 @ 50Hz		0.4A/230VAC	PF≥0.95/230VAC		
PET.2.2400	44	24	LED STRIP	100-120 @ 60Hz	60	0.8A/115VAC	PF≥0.97/115VAC	70	YES
				220-240 @ 50Hz		0.4A/230VAC	PF≥0.95/230VAC		

- 1 Wearing gloves, unpack the PETRA II fixture.
DO NOT remove calico wrapping until installation is complete.

- 2 Thread the power cable through one for the SUSPENSION RODS then secure the SUSPENSION RODS to the fixture frame by fastening them to the ALLTHREAD.

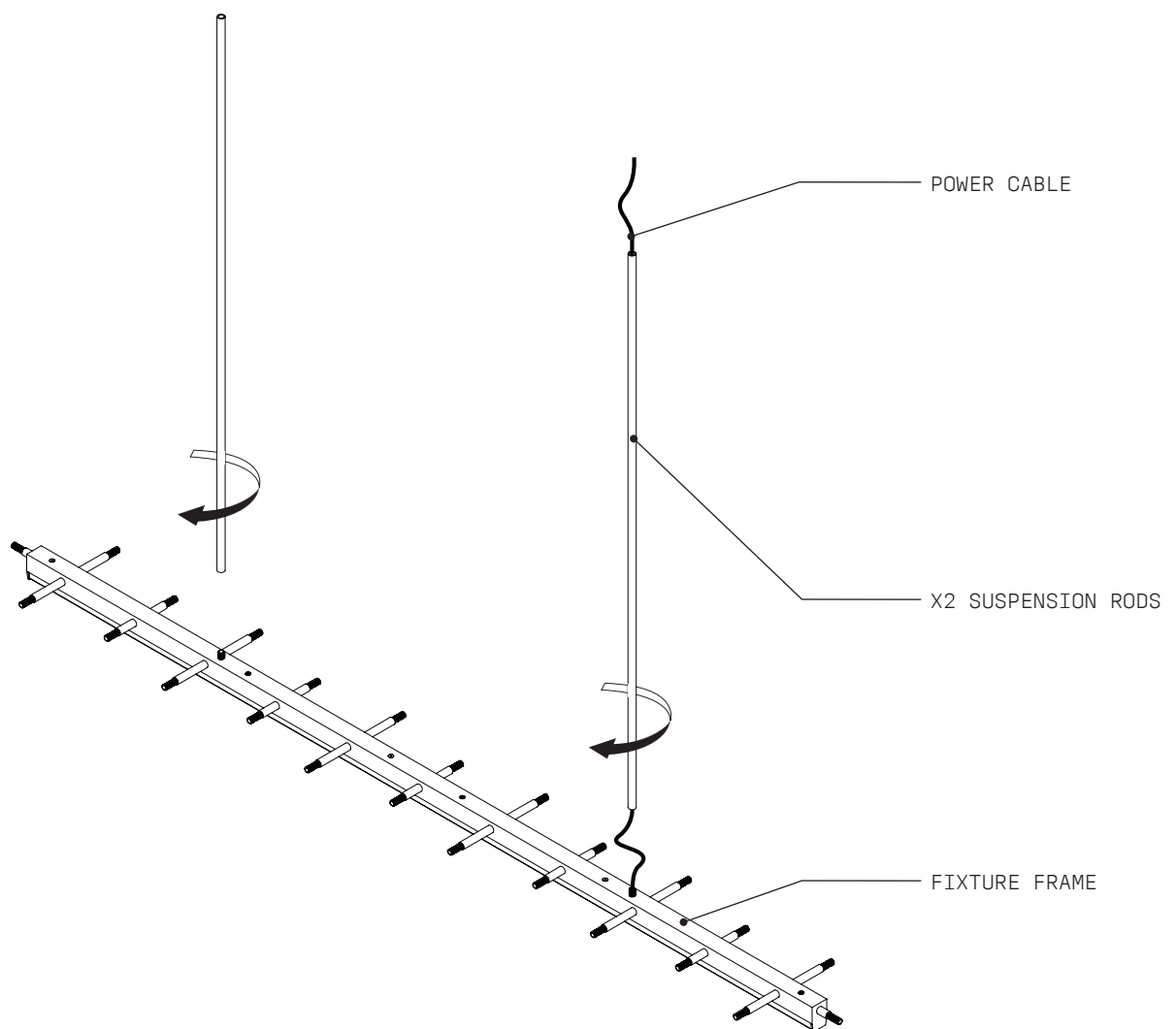

3 Refer to CANOPY INSTALLATION GUIDE to proceed.

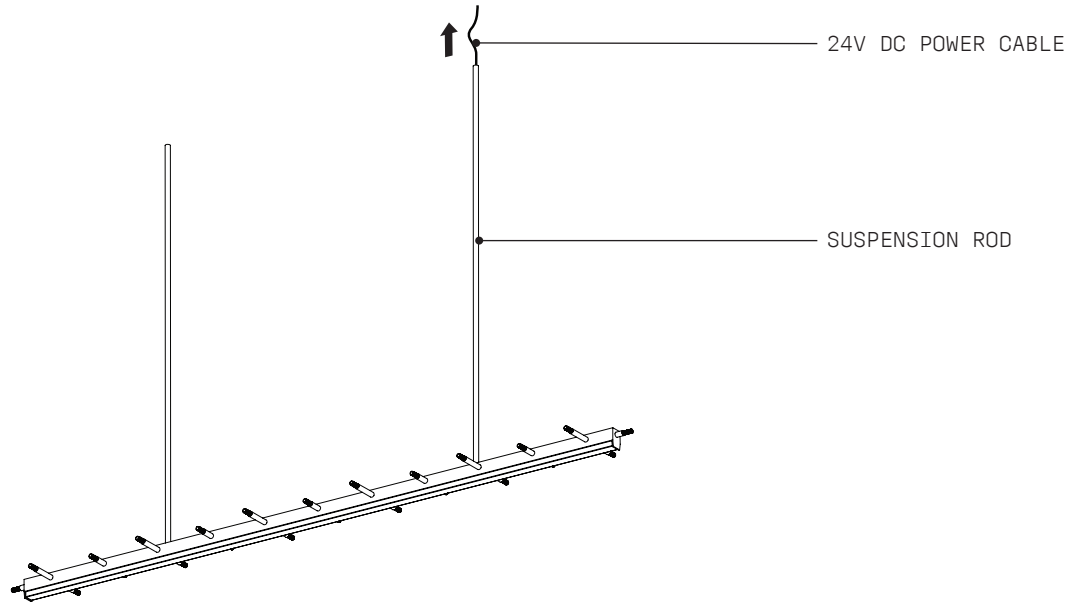

4 Once the fixture is suspended and secure, unwrap the quartz slices and begin to place them on to the ALLTHREAD, starting with the shorter COUPLERS. Fasten the Quartz in place using the provided FINIALS, ensure to put on the opposite slices to maintain the balance.

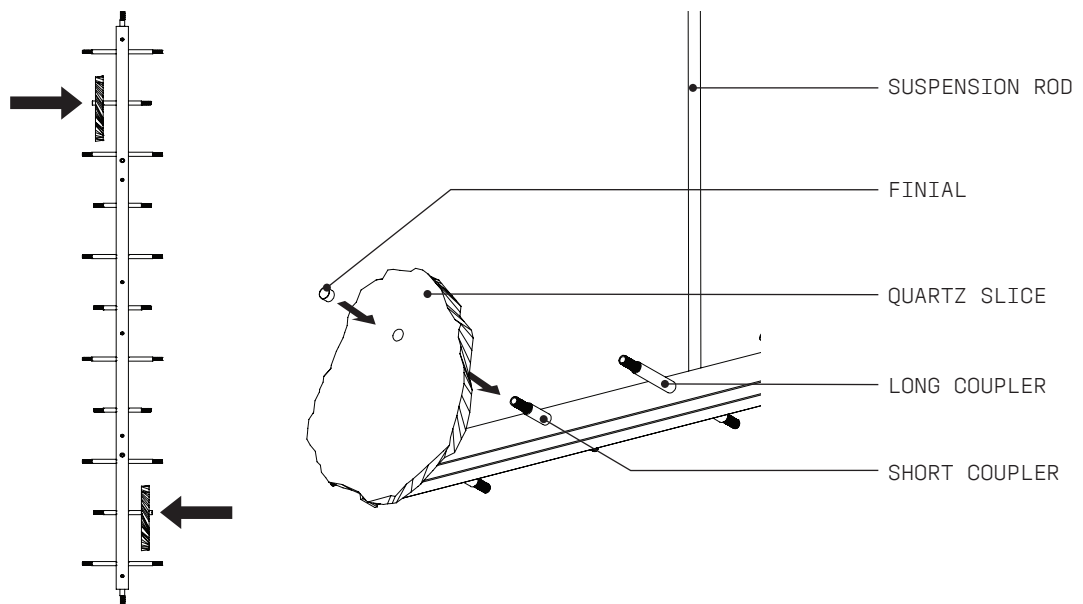

- 5 Once all the QUARTZ SLICES have been applied to the SHORT COUPLERS, repeat the same method for the LONG COUPLERS, again applying the opposite slices at a time to maintain the balance.

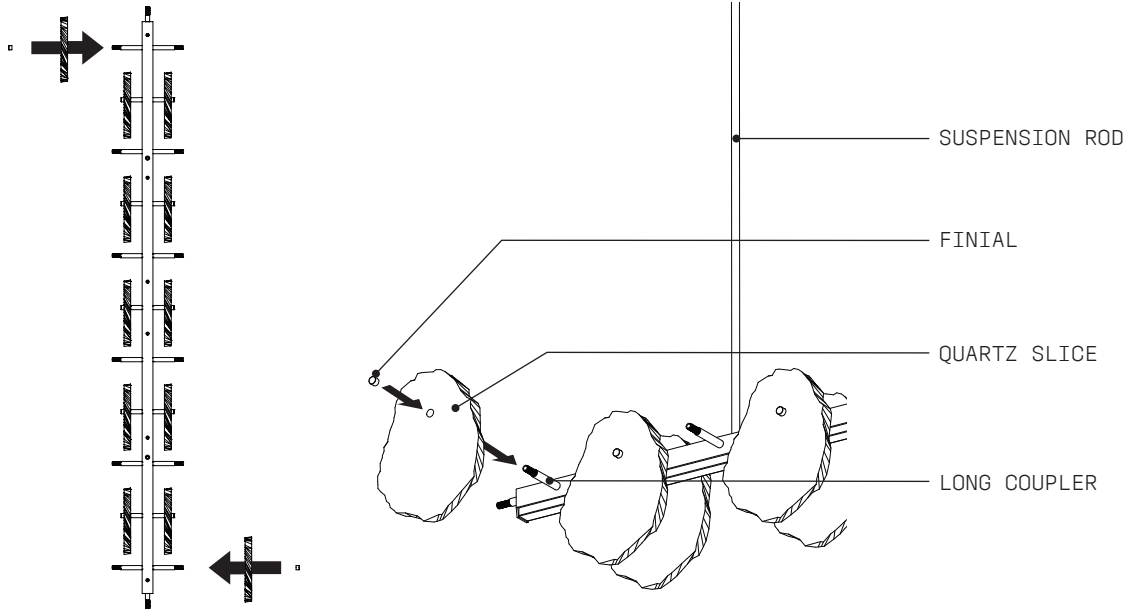

- 6 Finally attach the remaining 2 QUARTZ SLICES to the ends. Conduct a final visual assessment of PENDANT to ensure all parts have been properly fitted and secured. Once satisfied that everything is in working order, remove all remaining packaging to complete the installation. Please dispose of packaging material responsibly.

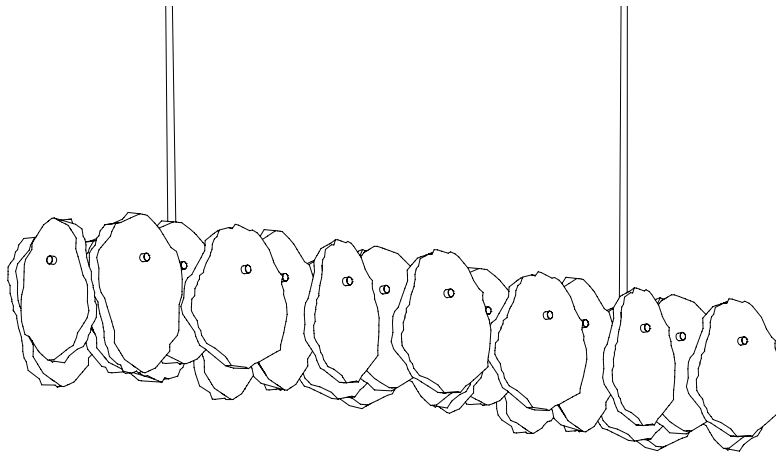

CARE INSTRUCTIONS:

PETRA II is a solid fixture that will require very little maintenance over the years, however changes in appearance of hand applied finishes or unlacquered finishes will vary as these (finshes) are designed to age in appearance. If your PETRA II is treated with care, it will shine brightly for many years to come. We recommend some general tips to help keep it shining its brightest;

Remove dust by simply running an electrostatic duster or dry cloth every few weeks over all exposed surfaces. Under no circumstances should the fixture be cleaned with any type of liquids/detergents or solvents. If more than dusting is required, please contact us at sales@christopherboots.com
We recommend the use of micro fibre cloths.

WARRANTY

1. CHRISTOPHER BOOTS offers a 36 month / 3 year warranty from date of receipt of balance payment on all light fittings supplied (not installation) against mechanical defects.
2. CHRISTOPHER BOOTS will repair or replace defective components or product within this warranty period.
3. Warranty for componentry includes:
4. Led lamps and strips: 3 years / 36 months after receipt.
5. Led drivers 60w: 3 years / 36 months after receipt.
6. Led drivers 100w + 150w: 5 years / 60 months after receipt.
7. Fixtures are labelled clearly with the maximum allowable wattage therefore responsibility of purchaser / end client to ensure correct lamps & wattages are compliant.
8. If unsure, please contact sales@christopherboots.com

CHRISTOPHER BOOTS WILL NOT BE HELD RESPONSIBLE FOR THE FOLLOWING:

1. Damage caused by improper cleaning solutions or methods.
2. Damage caused by improper installation or assembly by customer or customer's agent.
3. Damage caused by improper use of LED:
4. Damage caused by exposure to weather or improper environment – client to check IP rating prior to purchase.
5. Changes in appearance of hand applied finishes or unlacquered finishes.
*Please note that these finishes are designed to age in appearance.
6. Any costs of installation, removal, or re-installation.
7. Restoration, repair work & any parts purchased separately from supplied light fixtures.
8. Damage caused during shipping- all items are packed specifically for global transport.

DAMAGES

1. Damages must be documented and reported within 7 business days of receipt.
2. Photo evidence will be required upon reporting of damage claim.
3. CHRISTOPHER BOOTS is not responsible for repair or replacement of damages reported after this time.
4. If damage has occurred in shipping – all packaging must be retained by receiver. Failure to do so may invalidate any claim.

RETURNS

1. Because of the hand-made nature of our product, we are not able to offer returns.
2. Warranty claims, however will require client to cover shipping enroute back for repair.