

PROMETHEUS I 900

ROUND CANOPY + CABLER GLIDER MOUNTS VERTICAL SUSPENSION

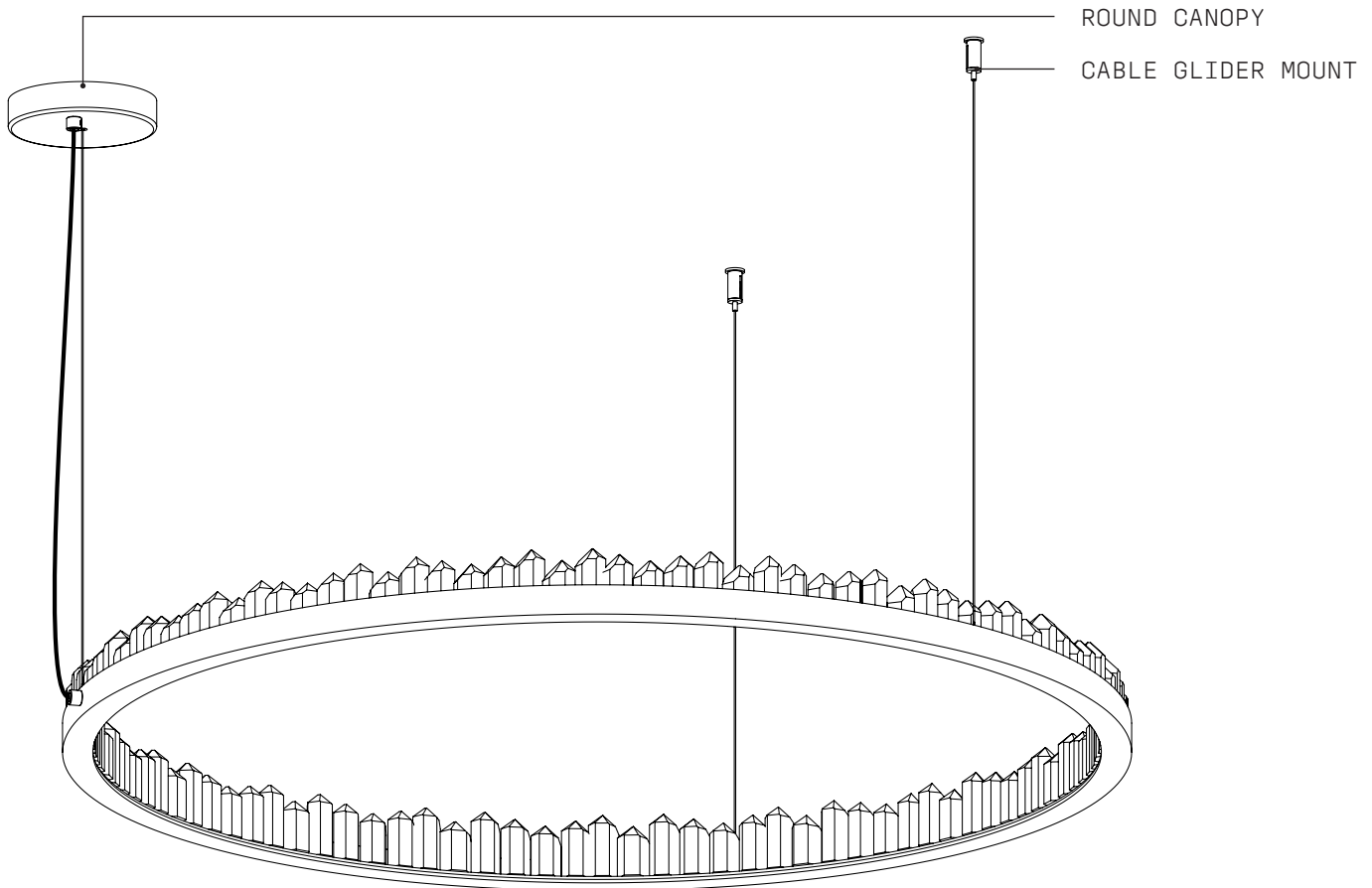

WARNING

ALL ELECTRICAL CONNECTIONS MUST BE MADE BY A QUALIFIED ELECTRICIAN IN ACCORDANCE WITH THE REGULATIONS AND CODES GOVERNING THE AREA FOR WHICH THE CHRISTOPHER BOOTS FIXTURE IS INTENDED TO BE INSTALLED IN. FAILURE TO DO SO MAY RESULT IN SERIOUS HARM OR DAMAGE TO PROPERTY AND LIFE, AT THE OWNER'S LIABILITY AND EXPENSE. CHRISTOPHER BOOTS WILL NOT BE HELD LIABLE FOR ANY DAMAGE CAUSED FROM INSTALLATION.

- 1 Wearing gloves, unpack POWER CABLE & SUSPENSION WIRES attached to the fixture.
Next unpack the ROUND CANOPY.
Do not unwrap the PENDANT, in order to prevent any damage that may occur during installation.

2 Ensure PENDANT is the right way up and SUSPENSION WIRES are not tangled.

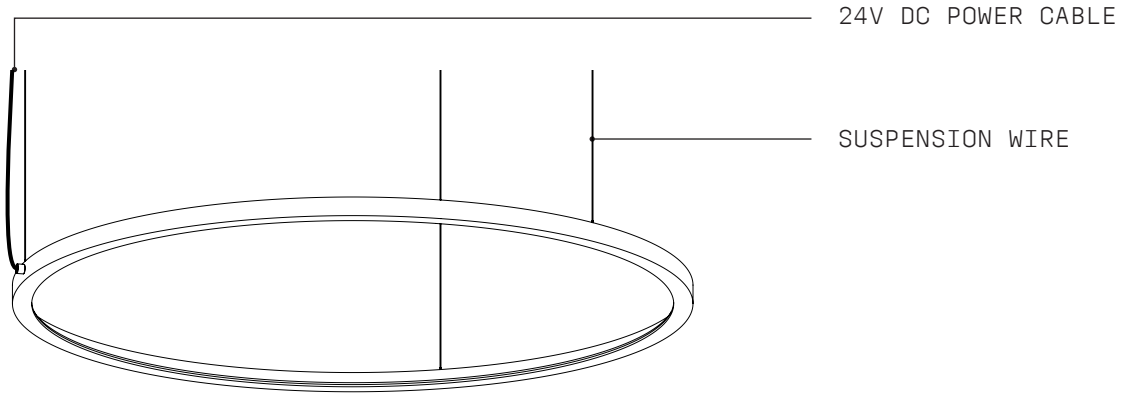

3 Refer to CANOPY SETOUT below.
Prepare ROUND CANOPY and CABLE GLIDER MOUNTS with their respective INSTALLATION GUIDES.

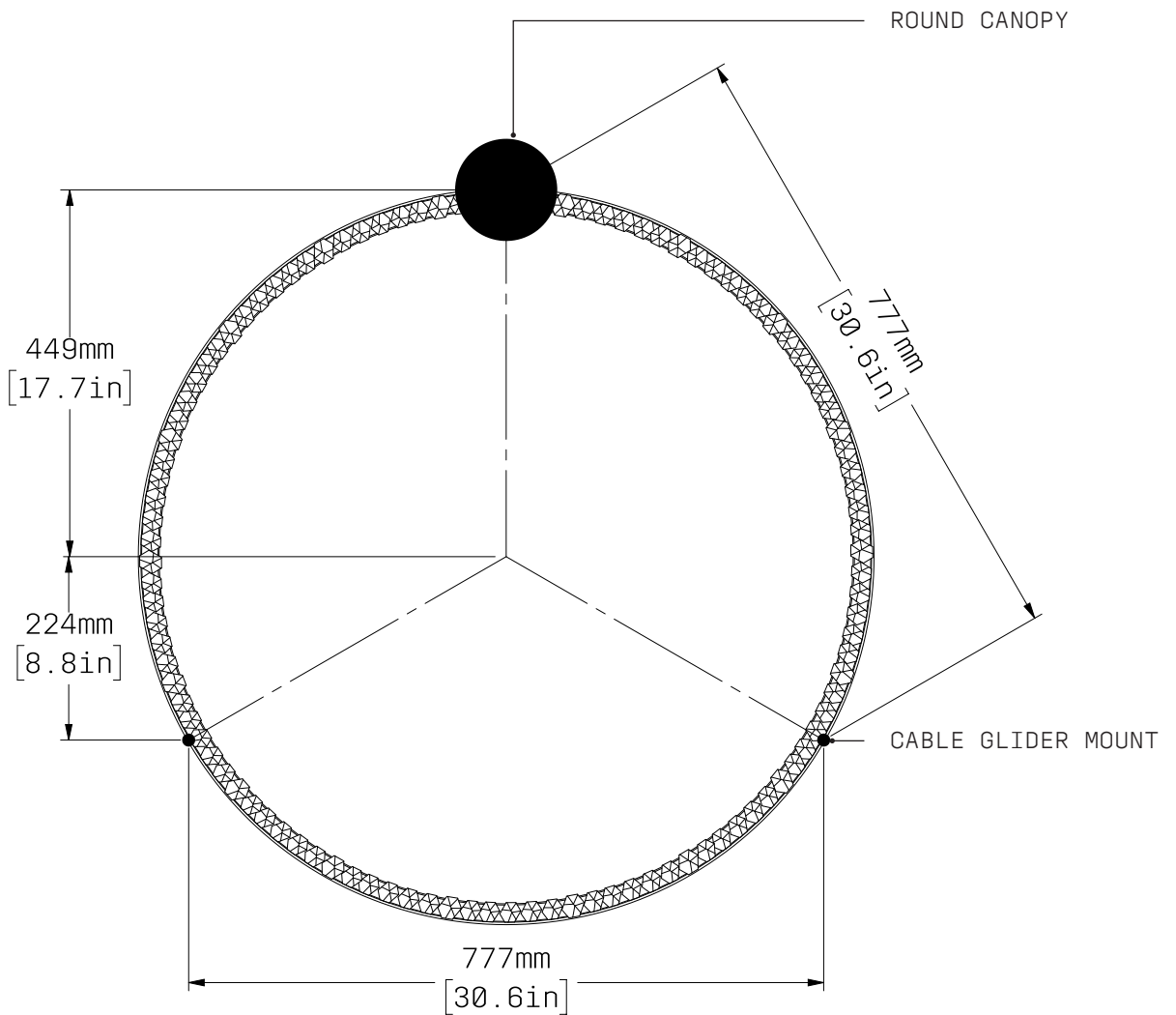

- 4 Wearing gloves, unpack QUARTZ CRYSTALS straight from the box onto WHITE MAGNETIC SURFACE of PENDANT.
 Start packing QUARTZ CRYSTALS onto PENDANT at 3 points, beginning at SUSPENSION WIRES.
 This will ensure the weight of QUARTZ CRYSTALS do not overload the fixture at any point.

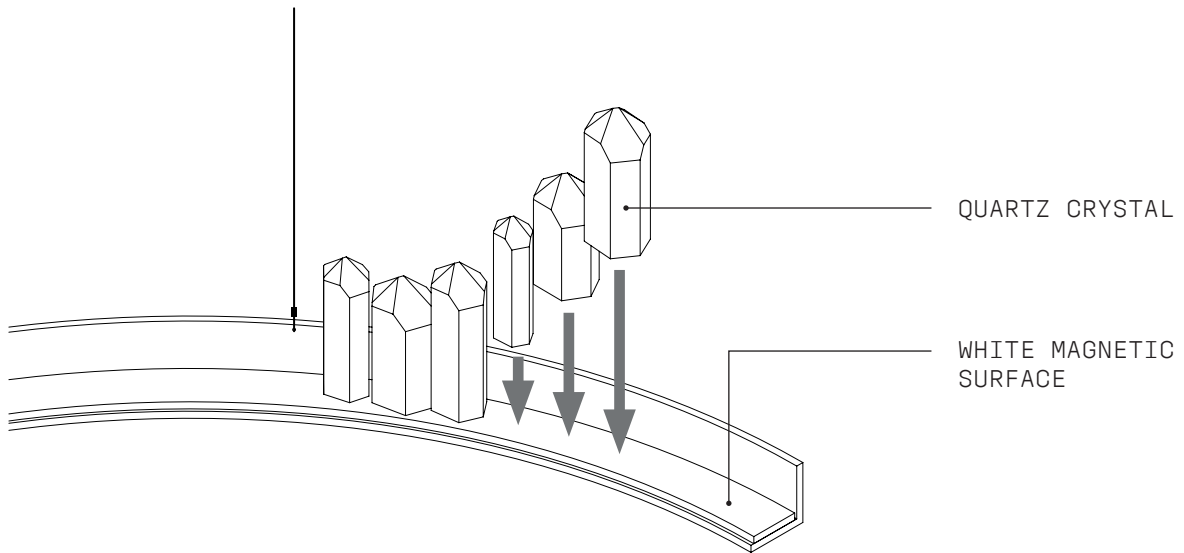

Ensure MAGNET on QUARTZ CRYSTAL makes full contact with WHITE MAGNETIC SURFACE on PENDANT.
 This may mean rotating the QUARTZ CRYSTAL until MAGNET makes full contact.
 Place QUARTZ CRYSTALS onto PENDANT tightly, without overlapping.
 Cover as much of the visible LED as possible.

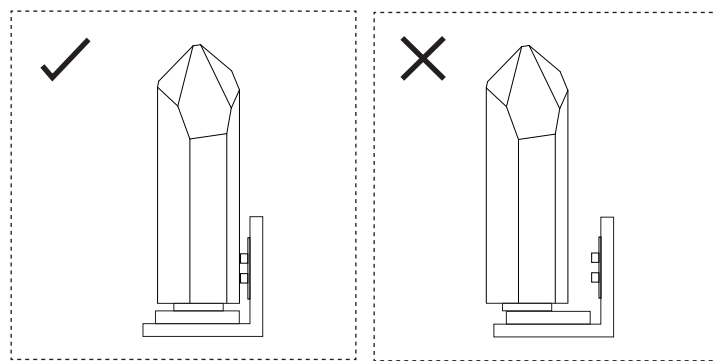

- 5 Conduct a final visual assessment of PROMETHEUS I to ensure proper fitting.
 Once satisfied everything is in working order, installation is complete.
 Please dispose of packaging material thoughtfully.
 PROMETHEUS I is a solid fixture requiring very little maintenance over the years. Changes in appearance of hand applied unlacquered finishes will vary as they are designed to age in appearance.
 If your PROMETHEUS I is treated with care, it will shine brightly for many years to come.

CARE INSTRUCTIONS

- The PROMETHEUS I pendant is for indoor use only and operable to a maximum ambient temperature of 60° Celsius. The lamping of this luminaire, is a non-user replaceable source and must only be replaced by CHRISTOPHER BOOTS, an appointed agent and/or qualified professional of CHRISTOPHER BOOTS. Should your pendant require relamping, please contact sales@christopherboots.com to make necessary arrangements.
- Remove dust by simply running an electrostatic duster or dry cloth every few weeks over all external surfaces.
- Take particular care when dusting internal surfaces as these are extremely delicate. A clean lint-free cloth will be ample.
- Crystals are attached with rare-earth magnets: they can easily be removed for washing in warm water and detergent whenever you feel the need for more sparkle.
- Under no circumstances should the fixture be cleaned with any type of liquids/detergents or solvents.
- We recommend using micro fibre cloths.
- If more than dusting is required, please contact us at: sales@christopherboots.com

WARRANTY

1. Christopher Boots offers a 36 month / 3 year warranty from date of receipt of balance payment on all light fittings supplied (not installation) against mechanical defects.
2. Christopher Boots will repair or replace defective components or product within this warranty period.
3. Warranty for components includes:
4. LED lamps and strips: 3 years / 36 months after receipt.
5. LED drivers 60w: 3 years / 36 months after receipt.
6. LED drivers 100w + 150w: 5 years / 60 months after receipt.
7. Incandescent lamps: no warranty – no manufacturer warrants filament lamps.
8. Fixtures are clearly labeled with maximum allowable wattage therefore responsibility of installer / end client to ensure correct lamps & wattages are compliant.
9. Use of higher wattage bulbs than indicated will forfeit warranty.
10. Warranty claims require client to cover shipping enroute back for repair.
11. Any questions? Contact sales@christopherboots.com

CHRISTOPHER BOOTS WILL NOT BE HELD RESPONSIBLE FOR THE FOLLOWING

1. Damage caused by improper cleaning solutions or methods.
2. Damage caused by improper installation or assembly by customer or customer's agent.
3. Damage caused by improper use of light bulbs:
4. Installers ensure screwing lamps / glass lamp cover inline with trajectory of product branch + lampholder upon lamp replacement.
5. A screwing motion of slightest angle may cause cross-threading & breakage not covered under warranty.
6. Damage caused by exposure to weather or improper environment – client to check IP rating prior to purchase.
7. Changes in appearance of hand applied finishes or unlacquered finishes.
8. Please note that finishes are designed to age in appearance.
9. Any costs of installation, removal, or re-installation.
10. Restoration, repair work & any parts purchased separately from supplied light fixtures.
11. Damage caused during shipping. All items are packed specifically for global transport.

DAMAGES

1. Damages must be documented and reported within 7 business days of receipt.
2. Photo evidence will be required upon reporting of damage claim.
3. Christopher Boots is not responsible for repair or replacement of damages reported after this time.
4. If damage has occurred in shipping, all packaging must be retained by receiver. Failure to do so may invalidate any claim.

RETURNS

1. Because of the hand-made nature of our product, we unable to offer returns.

WARRANTY AGAINST DEFECTS

A. Definitions

In this warranty **Australian Consumer Law** means the Australian consumer law set out in Schedule 2 to the Competition and Consumer Act 2010.

Goods means the product or equipment that was purchased in Australia and listed in the Applicable Product Ranges below.

Manufacturer, We or us means

Christopher Boots Pty Ltd
ABN 20 161 794 574

Supplier means the authorized distributor or the licensed electrical contractor that sold you the **Goods**.

You means you, the original end-user purchaser of the **Goods**.

B. Warranty Period and Details

The products detailed above are covered by a warranty against manufacturing faults and defects, provided that:

The product is properly installed, and installation is consistent with the manufacturer's instructions, and is installed by suitably trained and qualified installer. The product is not subjected to any unauthorised modifications.

The product is only used for the purpose of decorative illumination, in line with its designated purpose.

The product use is in normal conditions.

Any faults or defects attributable to the misuse, abuse, accident or non-observance of the manufacturer's instructions on the part of the user are specifically excluded.

C. Extent of the Warranty

Goods that prove defective within the Warranty Period by reason or improper workmanship or faulty material, we may, at our own discretion, either repair or replace the **Goods** without charge.

This warranty does not cover any cost related to removal, shipping to or from the return point, or reinstallation of the replace or repair item.

Any parts of the **Goods** replaced during repairs or any product replaced remains the property of Christopher Boots Pty Ltd.

In the event of the **Goods** being replaced during the **Warranty Period**, the warranty on the replacement **Goods** will expire on the same date as the **Warranty Period** of the original **Goods** they are replacing.

D. Applicable Date/Commencement of Warranty

This warranty commences from the date of purchase from the point of purchase from us. The details of the point of purchase, as well as all contact information for warranty claims and queries, are detailed below;

CHRISTOPHER BOOTS PTY LTD
328 Napier St. Fitzroy, Vic. Australia 3065
Ph: +61 3 9417 6501
Email: mail@christopherboots.com

E. Claim Process

The customer claim process is as follows:

The customer can make a claim, or enquire about the claim process, by contacting the company as detailed above.

The customer must provide a proof of purchase from the **Supplier**.

Before returning any goods for a warranty claim, the customer must obtain authorization and a Goods Return Authorization (GRA) notice. The customer, at their own expense, then forwards the goods, clearly marked with the GRA notice and with provision for return freight, to us (see above).

Upon receipt of the goods, we will review the claim, and proof of purchase.

If accepted as a valid warranty claim within the terms as described in this document, we will either make suitable repairs or provide an equivalent replacement product.

If the claim is rejected, the customer will be provided with a full explanation, and, if requested, the goods will be returned.

IMPORTANT

Our goods come with guarantees that cannot be excluded under the Australian Consumer Law. You are entitled to a replacement or refund for a major failure and for compensation for any other reasonably foreseeable loss or damage. You are also entitled to have the goods repaired or replaced if the goods fail to be of acceptable quality and the failure does not amount to a major failure.

The LED is designed to last for many years, and once it has expired, we offer a replacement service.

Contact us for more information.

PROMETHEUS I 1200

ROUND CANOPY + CABLER GLIDER MOUNTS VERTICAL SUSPENSION

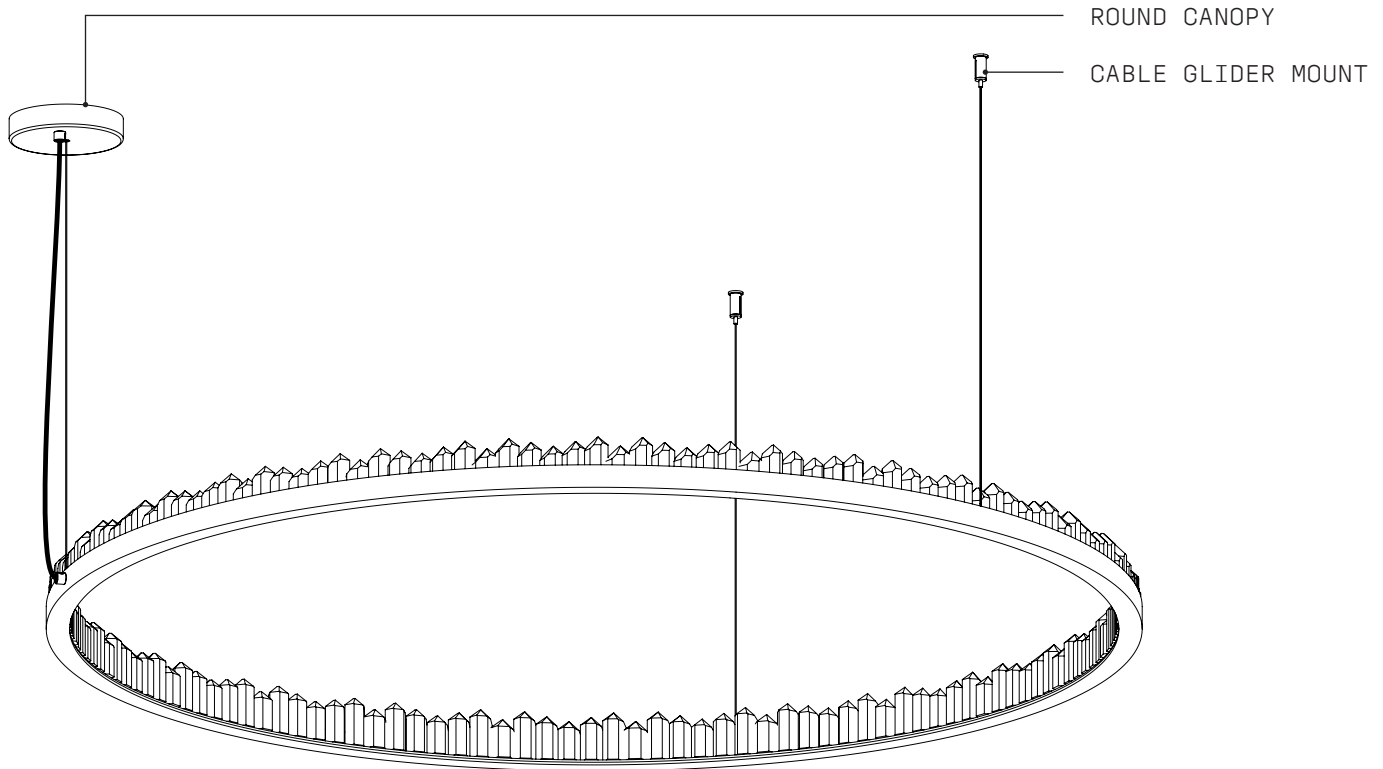

WARNING

ALL ELECTRICAL CONNECTIONS MUST BE MADE BY A QUALIFIED ELECTRICIAN IN ACCORDANCE WITH THE REGULATIONS AND CODES GOVERNING THE AREA FOR WHICH THE CHRISTOPHER BOOTS FIXTURE IS INTENDED TO BE INSTALLED. FAILURE TO DO SO MAY RESULT IN SERIOUS HARM OR DAMAGE TO PROPERTY AND LIFE, AT THE OWNER'S LIABILITY AND EXPENSE. CHRISTOPHER BOOTS WILL NOT BE HELD LIABLE FOR ANY DAMAGE CAUSED FROM INSTALLATION.

- 1 Wearing gloves, unpack POWER CABLE & SUSPENSION WIRES attached to the fixture.
Next unpack the ROUND CANOPY.
Do not unwrap the PENDANT, in order to prevent any damage that may occur during installation.

2 Ensure PENDANT is the right way up and SUSPENSION WIRES are not tangled.

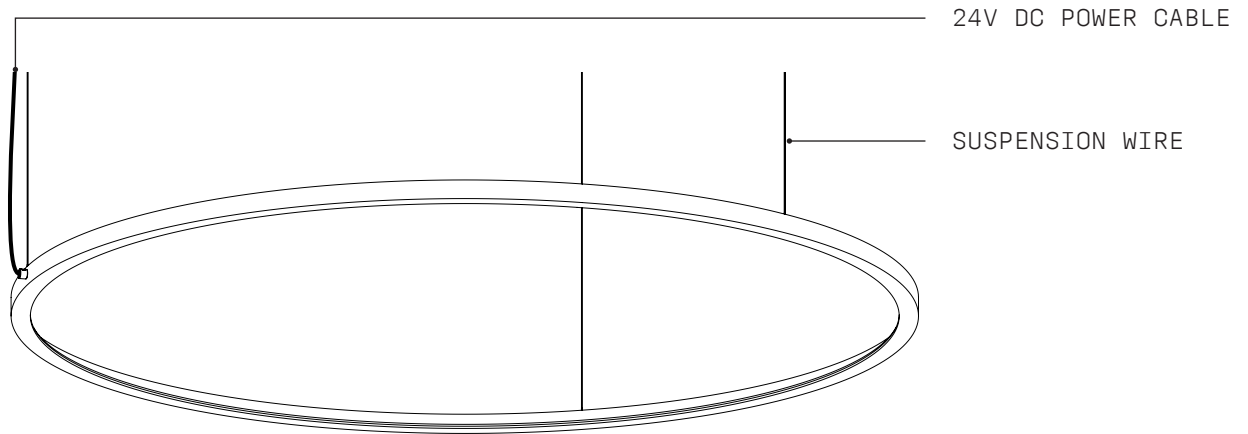

3 Refer to CANOPY SETOUT below.
Prepare ROUND CANOPY and CABLE GLIDER MOUNTS with their respective INSTALLATION GUIDES.

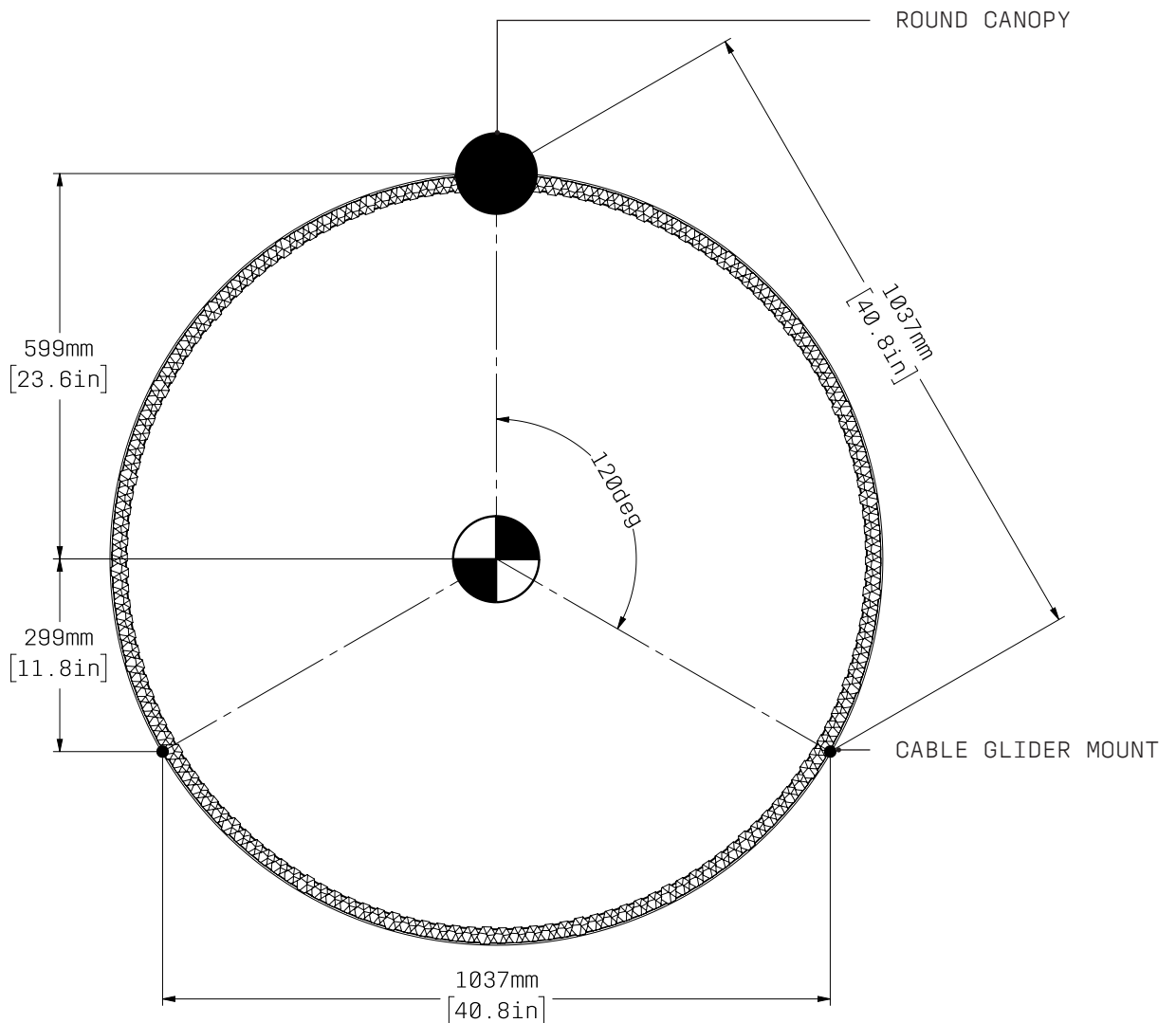

- 4 Wearing gloves, unpack QUARTZ CRYSTALS straight from the box onto WHITE MAGNETIC SURFACE of PENDANT.
 Start packing QUARTZ CRYSTALS onto PENDANT at 3 points, beginning at SUSPENSION WIRES.
 This will ensure the weight of QUARTZ CRYSTALS do not overload the fixture at any point.

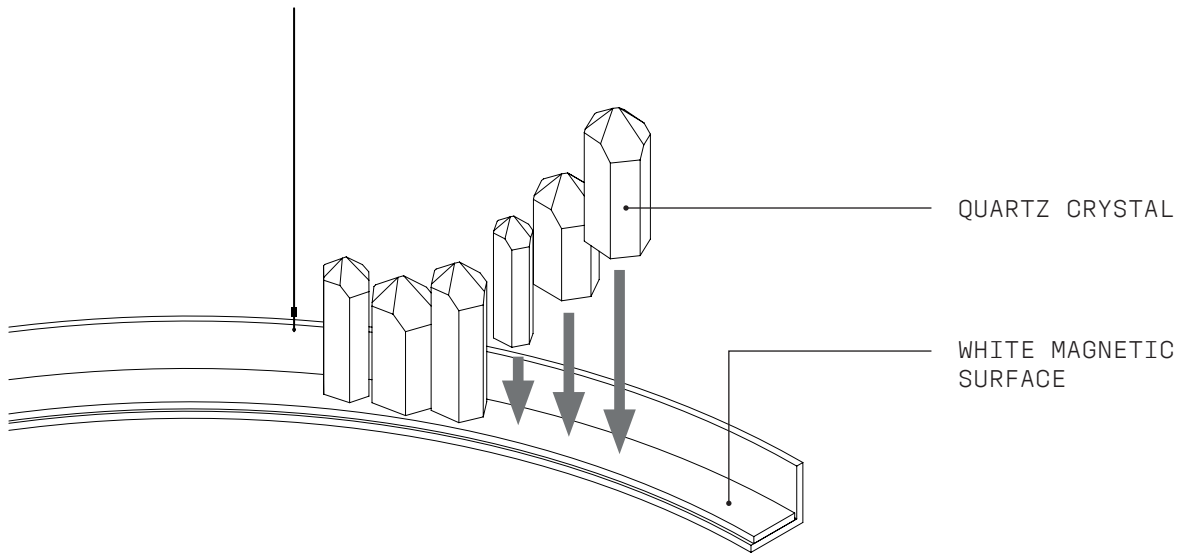

Ensure MAGNET on QUARTZ CRYSTAL makes full contact with WHITE MAGNETIC SURFACE on PENDANT.
 This may mean rotating the QUARTZ CRYSTAL until MAGNET makes full contact.
 Place QUARTZ CRYSTALS onto PENDANT tightly, without overlapping.
 Cover as much of the visible LED as possible.

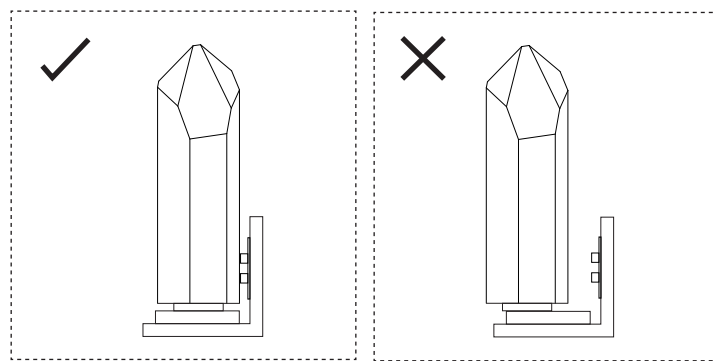

- 5 Conduct a final visual assessment of PROMETHEUS I to ensure proper fitting.

Once satisfied everything is in working order, installation is complete.

Please dispose of packaging material thoughtfully.

PROMETHEUS I is a solid fixture requiring very little maintenance over the years. Changes in appearance of hand applied unlacquered finishes will vary as they are designed to age in appearance.

If your PROMETHEUS I is treated with care, it will shine brightly for many years to come.

CARE INSTRUCTIONS

- The PROMETHEUS I pendant is for indoor use only and operable to a maximum ambient temperature of 60° Celsius. The lamping of this luminaire, is a non-user replaceable source and must only be replaced by CHRISTOPHER BOOTS, an appointed agent and/or qualified professional of CHRISTOPHER BOOTS. Should your pendant require relamping, please contact sales@christopherboots.com to make necessary arrangements.
- Remove dust by simply running an electrostatic duster or dry cloth every few weeks over all external surfaces.
- Take particular care when dusting internal surfaces as these are extremely delicate. A clean lint-free cloth will be ample.
- Crystals are attached with rare-earth magnets: they can easily be removed for washing in warm water and detergent whenever you feel the need for more sparkle.
- Under no circumstances should the fixture be cleaned with any type of liquids/detergents or solvents.
- We recommend using micro fibre cloths.
- If more than dusting is required, please contact us at: sales@christopherboots.com

WARRANTY

1. Christopher Boots offers a 36 month / 3 year warranty from date of receipt of balance payment on all light fittings supplied (not installation) against mechanical defects.
2. Christopher Boots will repair or replace defective components or product within this warranty period.
3. Warranty for components includes:
4. LED lamps and strips: 3 years / 36 months after receipt.
5. LED drivers 60w: 3 years / 36 months after receipt.
6. LED drivers 100w + 150w: 5 years / 60 months after receipt.
7. Incandescent lamps: no warranty – no manufacturer warrants filament lamps.
8. Fixtures are clearly labeled with maximum allowable wattage therefore responsibility of installer / end client to ensure correct lamps & wattages are compliant.
9. Use of higher wattage bulbs than indicated will forfeit warranty.
10. Warranty claims require client to cover shipping enroute back for repair.
11. Any questions? Contact sales@christopherboots.com

CHRISTOPHER BOOTS WILL NOT BE HELD RESPONSIBLE FOR THE FOLLOWING

1. Damage caused by improper cleaning solutions or methods.
2. Damage caused by improper installation or assembly by customer or customer's agent.
3. Damage caused by improper use of light bulbs:
4. Installers ensure screwing lamps / glass lamp cover inline with trajectory of product branch + lampholder upon lamp replacement.
5. A screwing motion of slightest angle may cause cross-threading & breakage not covered under warranty.
6. Damage caused by exposure to weather or improper environment – client to check IP rating prior to purchase.
7. Changes in appearance of hand applied finishes or unlacquered finishes.
8. Please note that finishes are designed to age in appearance.
9. Any costs of installation, removal, or re-installation.
10. Restoration, repair work & any parts purchased separately from supplied light fixtures.
11. Damage caused during shipping. All items are packed specifically for global transport.

DAMAGES

1. Damages must be documented and reported within 7 business days of receipt.
2. Photo evidence will be required upon reporting of damage claim.
3. Christopher Boots is not responsible for repair or replacement of damages reported after this time.
4. If damage has occurred in shipping, all packaging must be retained by receiver. Failure to do so may invalidate any claim.

RETURNS

1. Because of the hand-made nature of our product, we unable to offer returns.

WARRANTY AGAINST DEFECTS

A. Definitions

In this warranty **Australian Consumer Law** means the Australian consumer law set out in Schedule 2 to the Competition and Consumer Act 2010.

Goods means the product or equipment that was purchased in Australia and listed in the Applicable Product Ranges below.

Manufacturer, We or us means

Christopher Boots Pty Ltd
ABN 20 161 794 574

Supplier means the authorized distributor or the licensed electrical contractor that sold you the **Goods**.

You means you, the original end-user purchaser of the **Goods**.

B. Warranty Period and Details

The products detailed above are covered by a warranty against manufacturing faults and defects, provided that:

The product is properly installed, and installation is consistent with the manufacturer's instructions, and is installed by suitably trained and qualified installer. The product is not subjected to any unauthorised modifications.

The product is only used for the purpose of decorative illumination, in line with its designated purpose.

The product use is in normal conditions.

Any faults or defects attributable to the misuse, abuse, accident or non-observance of the manufacturer's instructions on the part of the user are specifically excluded.

C. Extent of the Warranty

Goods that prove defective within the Warranty Period by reason or improper workmanship or faulty material, we may, at our own discretion, either repair or replace the **Goods** without charge.

This warranty does not cover any cost related to removal, shipping to or from the return point, or reinstallation of the replace or repair item.

Any parts of the **Goods** replaced during repairs or any product replaced remains the property of Christopher Boots Pty Ltd.

In the event of the **Goods** being replaced during the **Warranty Period**, the warranty on the replacement **Goods** will expire on the same date as the **Warranty Period** of the original **Goods** they are replacing.

D. Applicable Date/Commencement of Warranty

This warranty commences from the date of purchase from the point of purchase from us. The details of the point of purchase, as well as all contact information for warranty claims and queries, are detailed below;

CHRISTOPHER BOOTS PTY LTD
328 Napier St. Fitzroy, Vic. Australia 3065
Ph: +61 3 9417 6501
Email: mail@christopherboots.com

E. Claim Process

The customer claim process is as follows:

The customer can make a claim, or enquire about the claim process, by contacting the company as detailed above.

The customer must provide a proof of purchase from the **Supplier**.

Before returning any goods for a warranty claim, the customer must obtain authorization and a Goods Return Authorization (GRA) notice. The customer, at their own expense, then forwards the goods, clearly marked with the GRA notice and with provision for return freight, to us (see above).

Upon receipt of the goods, we will review the claim, and proof of purchase.

If accepted as a valid warranty claim within the terms as described in this document, we will either make suitable repairs or provide an equivalent replacement product.

If the claim is rejected, the customer will be provided with a full explanation, and, if requested, the goods will be returned.

IMPORTANT

Our goods come with guarantees that cannot be excluded under the Australian Consumer Law. You are entitled to a replacement or refund for a major failure and for compensation for any other reasonably foreseeable loss or damage. You are also entitled to have the goods repaired or replaced if the goods fail to be of acceptable quality and the failure does not amount to a major failure.

The LED is designed to last for many years, and once it has expired, we offer a replacement service.

Contact us for more information.

PROMETHEUS I

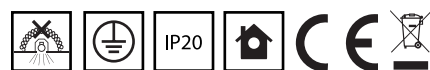
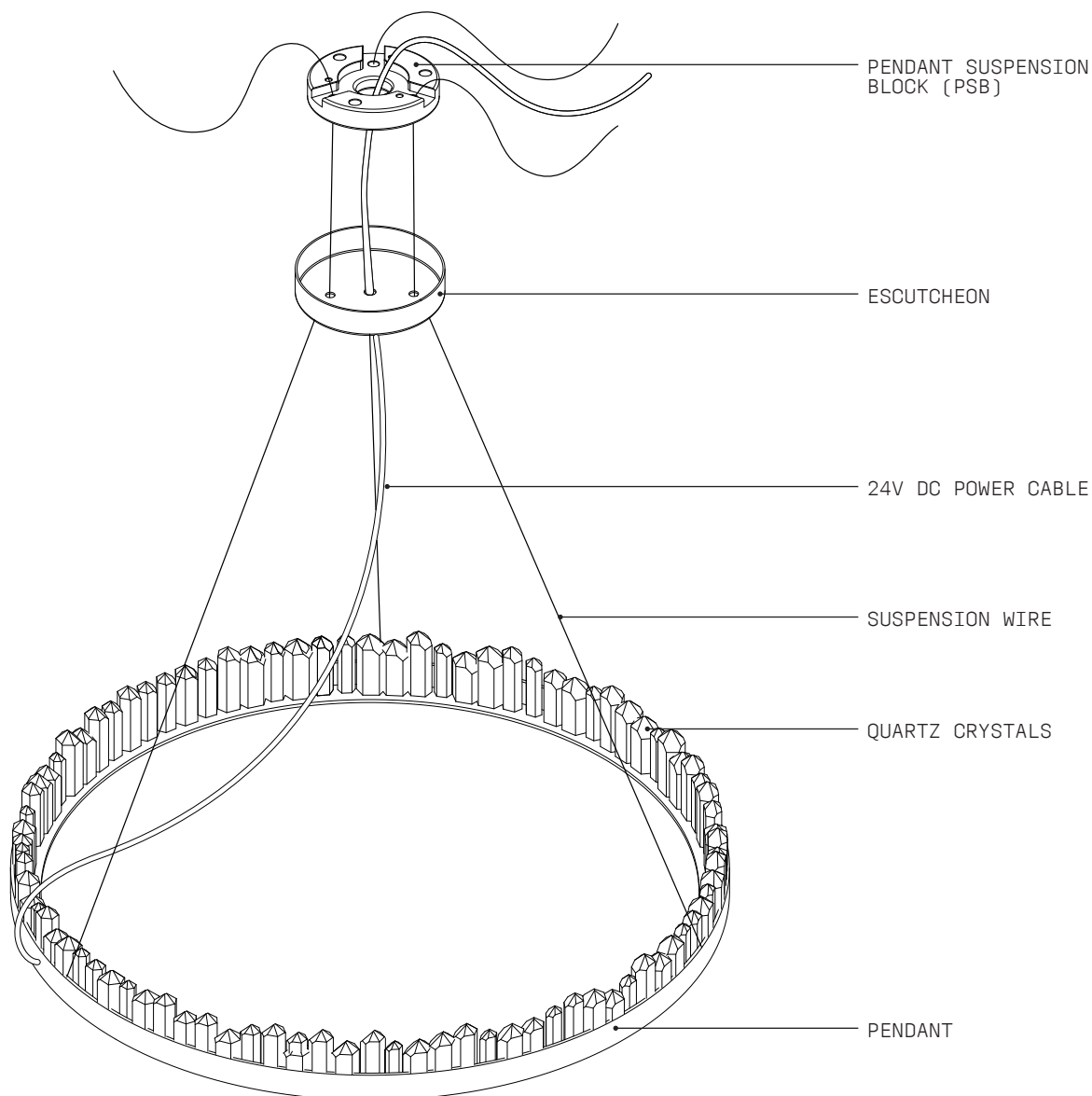



WARNING: SHOCK HAZARD

May result in serious injury or death.
ENSURE POWER IS OFF before commencing any work.

WARNING: ELECTRICAL

ALL ELECTRICAL connections must be made by a qualified electrician in accordance with the regulations and codes governing the area for which the CHRISTOPHER BOOTS Fixture is intended to be installed in. Failure to do so may result in serious harm or damage to property and life, at the owner's liability and expense.

CHRISTOPHER BOOTS will not be held liable for any damage caused from installation.



WARNING: STRUCTURAL

Ensure that the substrate is securely installed and is in accordance with local building regulations. Failure to do so may potentially result in serious harm or damage of property, at the owner's liability and expense.

CHRISTOPHER BOOTS will not be held liable for any damage caused from installation.



Refer to supplied WIRING DIAGRAM.

TECHNICAL INFORMATION									
MODEL	MAX WATTAGE	FIXTURE VOLTAGE (CV)	LAMP TYPE	POWER SUPPLY INPUT VOLTAGE (V AC)	POWER SUPPLY WATTAGE (W)	POWER SUPPLY INPUT CURRENT (typ.)	POWER SUPPLY POWER FACTOR (typ.)	FIXTURE WEIGHT (KG)	EARTH IN CANOPY
P1.450	27	24	LED STRIP	127 @ 60Hz	60	0.8A/127VAC	PF≥0.97/127VAC	7	YES
				220 @ 60Hz		0.4A/230VAC	PF≥0.95/220VAC		
P1.600	36	24	LED STRIP	127 @ 60Hz	60	0.8A/127VAC	PF≥0.97/127VAC	9	YES
				220 @ 60Hz		0.4A/230VAC	PF≥0.95/220VAC		
P1.900	54	24	LED STRIP	127 @ 60Hz	100	1.2A/127VAC	PF≥0.98/127VAC	14	YES
				220 @ 60Hz		0.55A/230VAC	PF≥0.95/220VAC		
P1.1200	72	24	LED STRIP	127 @ 60Hz	100	1.2A/127VAC	PF≥0.98/127VAC	19	YES
				220 @ 60Hz		0.55A/230VAC	PF≥0.95/220VAC		
P1.1500	90	24	LED STRIP	127 @ 60Hz	150	1.7A/127VAC	PF≥0.98/127VAC	23	YES
				220 @ 60Hz		0.75A/230VAC	PF≥0.95/220VAC		
P1.1800	108	24	LED STRIP	127 @ 60Hz	150	1.7A/127VAC	PF≥0.98/127VAC	28	YES
				220 @ 60Hz		0.75A/230VAC	PF≥0.95/220VAC		
P1.2100	126	24	LED STRIP	127 @ 60Hz	150	1.7A/127VAC	PF≥0.98/127VAC	33	YES
				220 @ 60Hz		0.75A/230VAC	PF≥0.95/220VAC		

- 1 Wearing gloves, unpack the 24V DC POWER CABLE & SUSPENSION WIRES attached to the PENDANT.

Next unpack the supplied CEILING CANOPY (Illustrations may differ to supplied canopy).

Do not unwrap the PENDANT, in order to prevent any damage that may occur during installation.

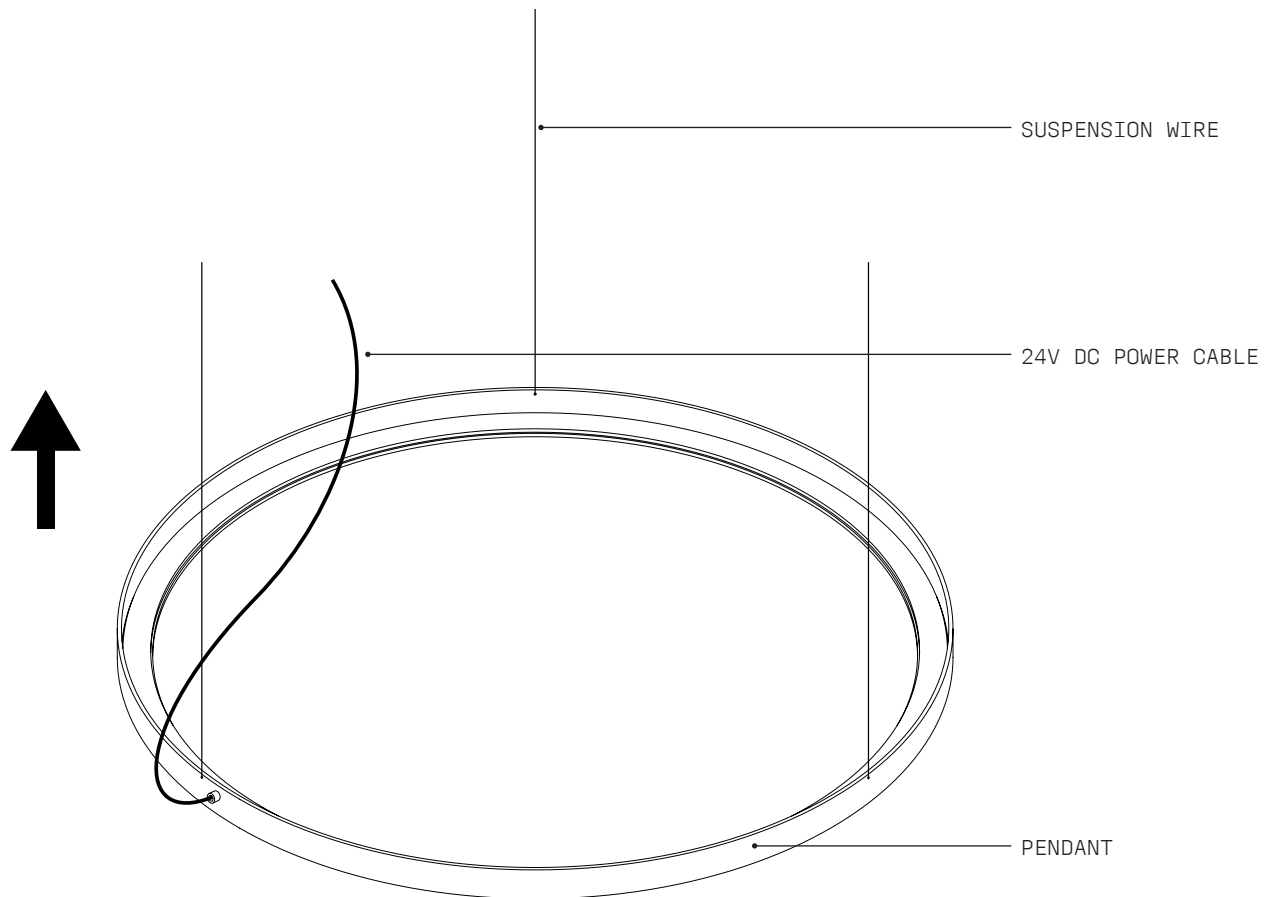

- 2 Ensure that the PENDANT is the right way up as per diagram and that the SUSPENSION WIRES are not tangled.
Feed the 24V DC POWER CABLE and SUSPENSION WIRES through their corresponding positions in the escutcheon and the pendant suspension block, as per supplied CANOPY INSTALLATION GUIDE.

- 3 — Connect the 24V DC POWER CABLE from the PENDANT to supplied POWER SUPPLY UNIT. Refer to supplied WIRING DIAGRAM →



- 4 — Refer to the CANOPY INSTALLATION GUIDE to correctly install all canopy components.

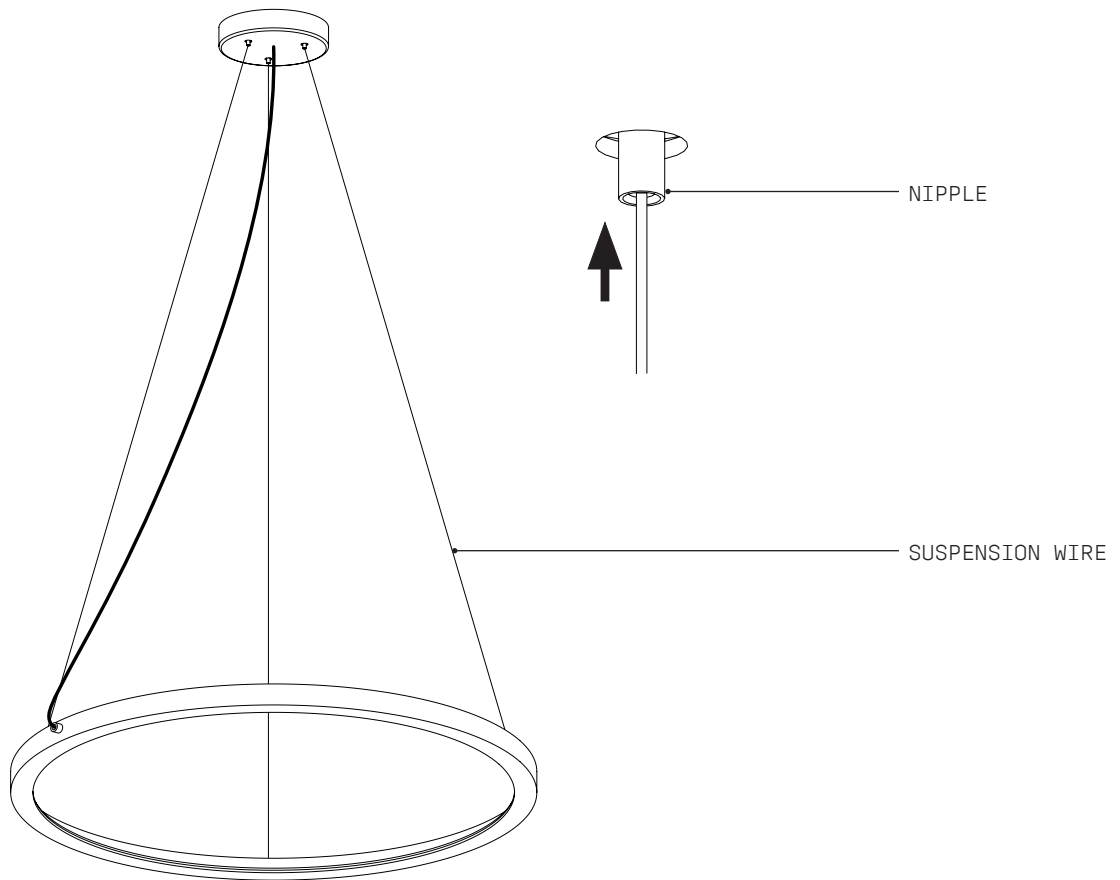

- 5 — Adjust the level of the fixture using the adjustable CABLE GLIDERS. The lengths of the SUSPENSION WIRES can be adjusted to be lower by taking the weight off the suspension wire, and pushing on the spring loaded NIPPLE on the CABLE GLIDER to release.

Remember to always support the fixture during this process. Once settled on the level of the fixture, remove any remaining protective packaging.

- 6 — Unpack the MAGNETISED CRYSTALS straight from the box onto the MAGNETIC SURFACE of the ring. Begin placing them from any chosen SUSPENSION WIRE.

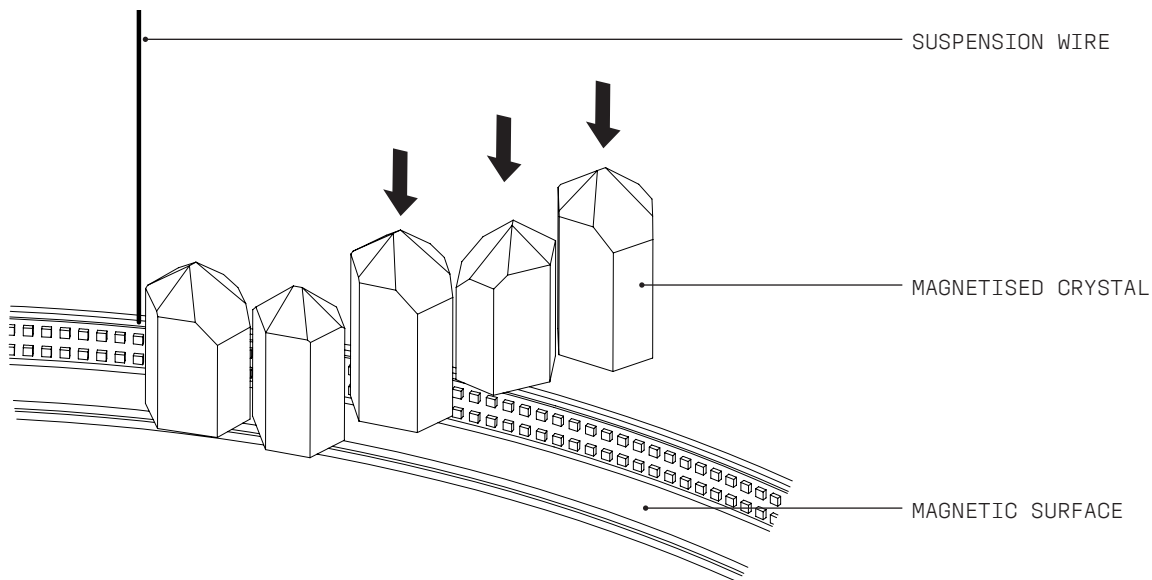

- 7 — Ensure that the MAGNET on the crystal makes full contact with the MAGNETIC SURFACE on the ring.

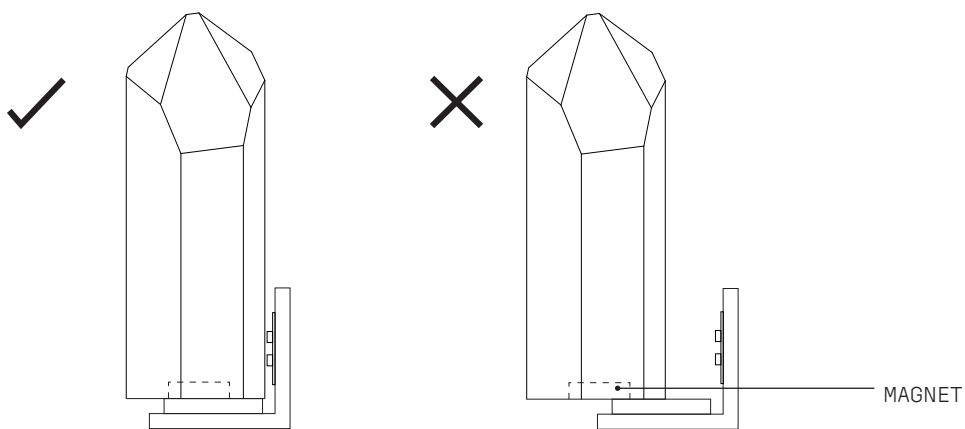

- 8
- Rotate magnetised crystals until the magnet makes full contact with magnetic surface.
 - Pack the crystals onto the ring tightly, without overlapping. Cover as much visible LED as possible.
 - If crystal selection does not fit as desired, there are spare crystals to use in place of others.

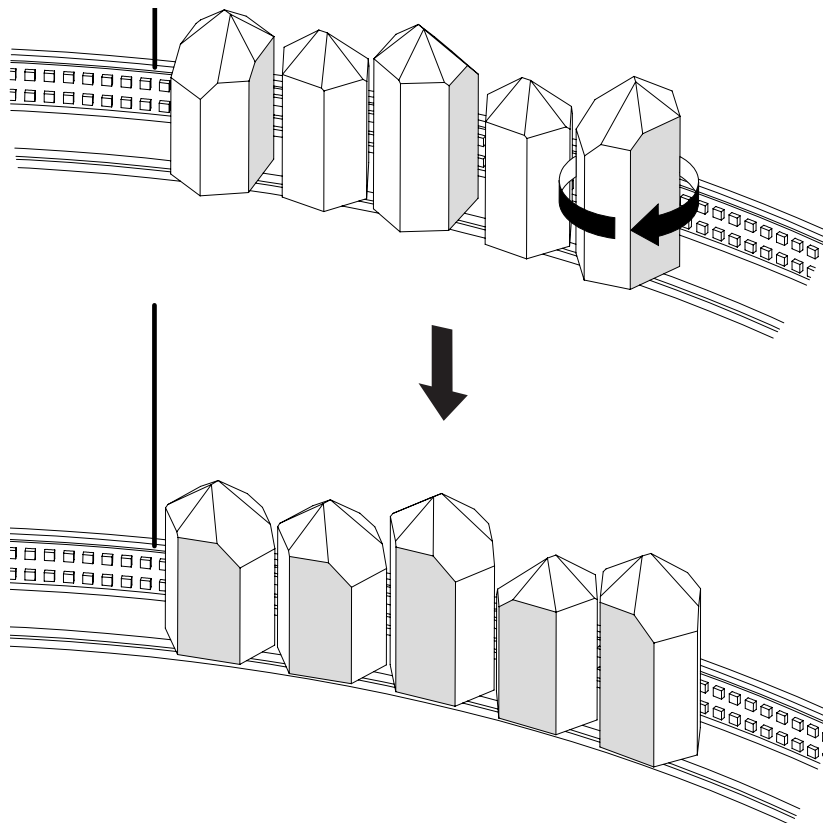

- 9
- Some MAGNETS are not central to the crystal. Rotate the crystal so each MAGNET sits closest to the RING. It is normal if a small portion of the crystal is hanging over the edge of the ring.

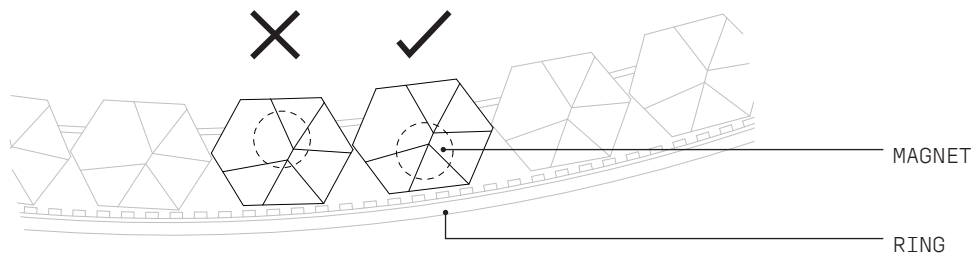

- 10 — Weight and arrangement of crystals may cause the pendant to become unbalanced. Check that the pendant is still level, and re-adjust if necessary, following instructions from Step. 5

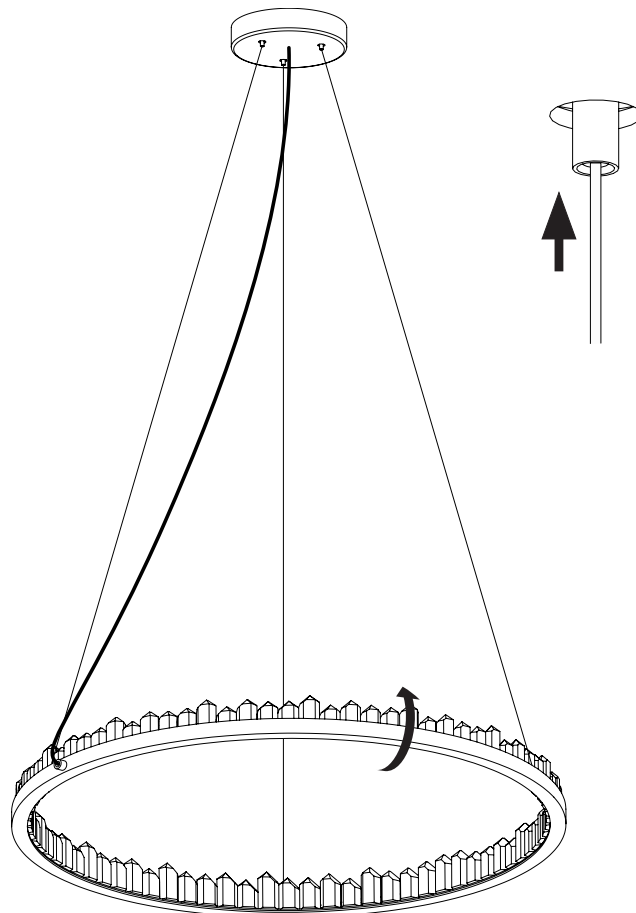

- 11 — Conduct a final visual assessment of the fixture to ensure all parts have been properly fitted and secured. Once satisfied that everything is in working order, the installation process is complete.

FINISH

The PROMETHEUS PENDANT is for indoor use only and operable to a maximum ambient temperature of 60° celsius. The lamping of this luminaire, is a non-user replaceable source and must only be replaced by CHRISTOPHER BOOTS, an appointed agent and/or qualified professional of CHRISTOPHER BOOTS. Should your pendant require relamping, please contact CHRISTOPHER BOOTS by sending an email to sales@christopherboots.com to make the necessary arrangements.



THE LIGHT SOURCE CONTAINED IN THIS LUMINAIRE SHALL ONLY BE REPLACED BY THE MANUFACTURER OR THEIR REPRESENTATIVE AGENT OR A SIMILAR QUALIFIED PERSON

CARE INSTRUCTIONS:

PROMETHEUS is a solid fixture that will require very little maintenance over the years, however changes in appearance of hand applied finishes or unlacquered finishes will vary as these (finishes) are designed to age in appearance. If your PROMETHEUS is treated with care, it will shine brightly for many years to come. We recommend some general tips to help keep it shining its brightest:

- Remove dust by simply running an electrostatic duster or dry cloth every few weeks over all exposed surfaces.
- Under no circumstances should the fixture be cleaned with any type of liquids/detergents or solvents.
- If more than dusting is required, please contact us at:
sales@christopherboots.com
- We recommend the use of micro fibre cloths.

WARRANTY

1. CHRISTOPHER BOOTS offers a 36 month / 3 year warranty from date of receipt of balance payment on all light fittings supplied (not installation) against mechanical defects.
2. CHRISTOPHER BOOTS will repair or replace defective components or product within this warranty period.
3. Warranty for componentry includes:
4. LED lamps and strips: 3 years / 36 months after receipt.
5. LED POWER SUPPLYs 60w: 3 years / 36 months after receipt.
6. LED POWER SUPPLYs 100w + 150w: 5 years / 60 months after receipt.
7. If unsure, please contact sales@christopherboots.com

Christopher Boots will not be held responsible for the following:

1. Damage caused by improper cleaning solutions or methods.
2. Damage caused by improper installation or assembly by customer or customer's agent.
3. Damage caused by improper use of LED:
4. Damage caused by exposure to weather or improper environment – client to check IP rating prior to purchase.
5. Changes in appearance of hand applied finishes or unlacquered finishes.
*Please note that these finishes are designed to age in appearance.
6. Any costs of installation, removal, or re-installation.
7. Restoration, repair work & any parts purchased separately from supplied light fixtures.
8. Damage caused during shipping – all items are packed specifically for global transport.

DAMAGES

1. Damages must be documented and reported within 7 business days of receipt.
2. Photo evidence will be required upon reporting of damage claim.
3. CHRISTOPHER BOOTS is not responsible for repair or replacement of damages reported after this time.
4. If damage has occurred in shipping – all packaging must be retained by receiver. Failure to do so may invalidate any claim.

RETURNS

1. Because of the hand-made nature of our product, we are not able to offer returns.
2. Warranty claims, however will require client to cover shipping enroute back for repair

A. DEFINITIONS

In this warranty Australian Consumer Law means the Australian consumer law set out in Schedule 2 to the Competition and Consumer Act 2010.

Goods means the product or equipment that was purchased in Australia and listed in the Applicable Product Ranges below.

Manufacturer, We or Us means:
CHRISTOPHER BOOTS Pty Ltd
ABN 20 161 794 574

Supplier means the authorized distributor or the licensed electrical contractor that sold you the Goods.

You means you, the original end-user purchaser of the Goods.

B. WARRANTY PERIOD AND DETAILS

The products detailed above are covered by a warranty against manufacturing faults and defects, provided that:

The product is properly installed, and installation is consistent with the manufacturer's instructions, and is installed by suitably trained and qualified installer. The product is not subjected to any unauthorised modifications.

The product is only used for the purpose of decorative illumination, in line with its designated purpose.

The product use is in normal conditions.

Any faults or defects attributable to the misuse, abuse, accident or non-observance of the manufacturer's instructions on the part of the user are specifically excluded.

C. EXTENT OF THE WARRANTY

GOODS that prove defective within the Warranty Period by reason of improper workmanship or faulty material, we may, at our own discretion, either repair or replace the GOODS without charge.

This warranty does not cover any cost related to removal, shipping to or from the return point, or reinstallation of the replace or repair item.

Any parts of the GOODS replaced during repairs or any product replaced remain the property of CHRISTOPHER BOOTS Pty Ltd.

In the event of the GOODS being replaced during the WARRANTY PERIOD, the warranty on the replacement GOODS will expire on the same date as the WARRANTY PERIOD of the original GOODS they are replacing.

D. APPLICABLE DATE/COMMENCEMENT OF WARRANTY

This warranty commences from the date of purchase from the point of purchase from CHRISTOPHER BOOTS Pty Ltd. The details of the point of purchase, as well as all contact information for warranty claims and queries, are detailed below;

CHRISTOPHER BOOTS Pty Ltd.
369 Gore St. Fitzroy, Vic. Australia 3065
Ph: +61 3 9417 6501
Email: sales@christopherboots.com

E. CLAIM PROCESS

The customer claim process is as follows; The customer can make a claim, or enquire about the claim process, by contacting the company as detailed above.

The customer must provide a proof of purchase from the SUPPLIER.

Before returning any goods for a warranty claim, the customer must obtain authorization and a Goods Return Authorisation (GRA) notice. The customer, at their own expense, then forwards the goods, clearly marked with the GRA notice and with provision for return freight, to CHRISTOPHER BOOTS Pty Ltd (see above).

Upon receipt of the goods, CHRISTOPHER BOOTS Pty Ltd will review the claim, and proof of purchase.

If accepted as a valid warranty claim within the terms as described in this document, CHRISTOPHER BOOTS Pty Ltd will either make suitable repairs or provide an equivalent replacement product.

If the claim is rejected, the customer will be provided with a full explanation, and if requested, the goods will be returned.

IMPORTANT:

Our goods come with guarantees that cannot be excluded under the Australian Consumer Law. You are entitled to a replacement or refund for a major failure and for compensation for any other reasonably foreseeable loss or damage. You are also entitled to have the goods repaired or replaced if the goods fail to be of acceptable quality and the failure does not amount to a major failure.

PROMETHEUS II

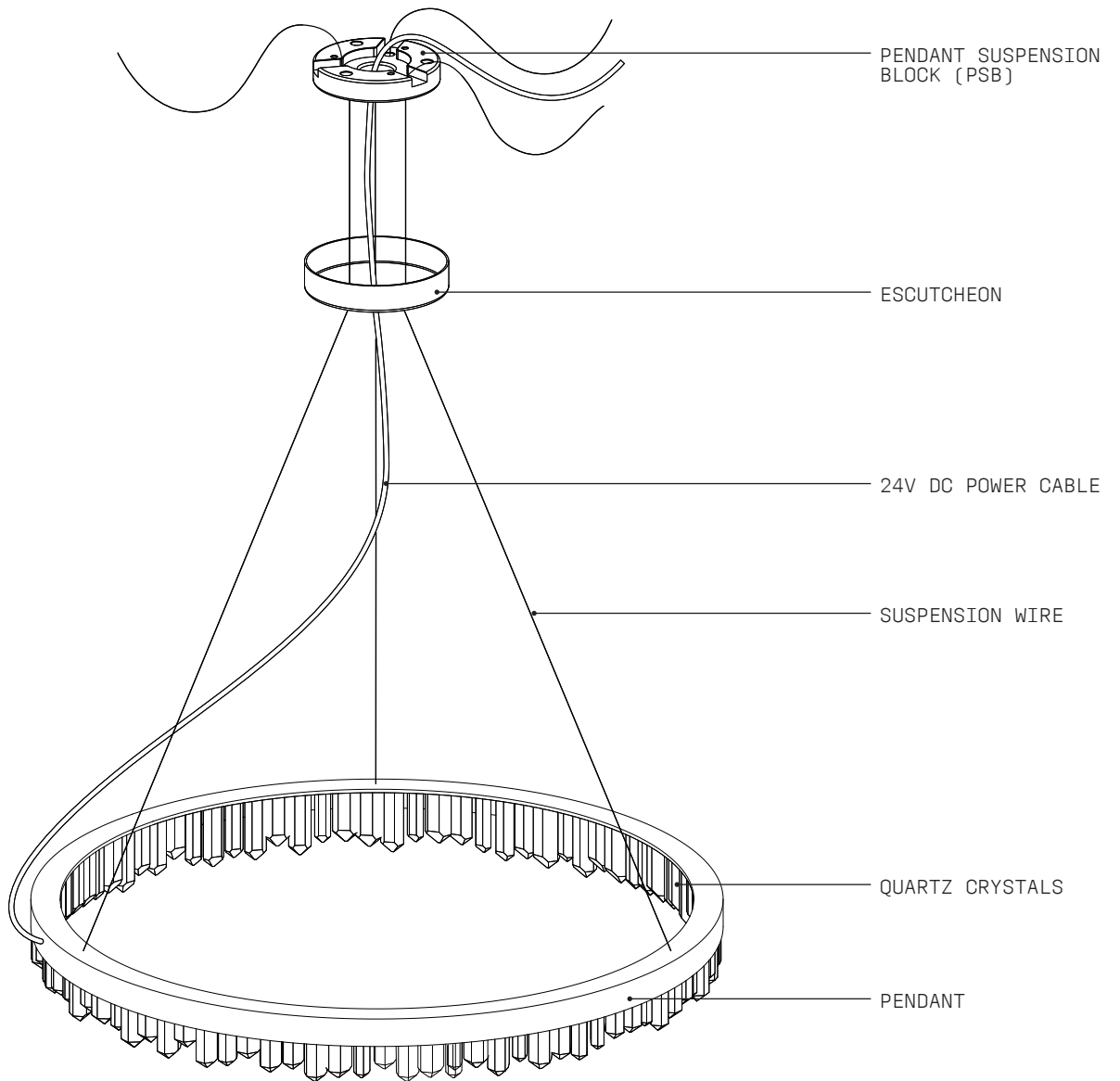



WARNING: SHOCK HAZARD

May result in serious injury or death.
ENSURE POWER IS OFF before commencing any work.

WARNING: ELECTRICAL

ALL ELECTRICAL connections must be made by a qualified electrician in accordance with the regulations and codes governing the area for which the CHRISTOPHER BOOTS Fixture is intended to be installed in. Failure to do so may result in serious harm or damage to property and life, at the owner's liability and expense.

CHRISTOPHER BOOTS will not be held liable for any damage caused from installation.



WARNING: STRUCTURAL

Ensure that the substrate is securely installed and is in accordance with local building regulations. Failure to do so may potentially result in serious harm or damage of property, at the owner's liability and expense.

CHRISTOPHER BOOTS will not be held liable for any damage caused from installation.



Refer to supplied WIRING DIAGRAM.

TECHNICAL INFORMATION									
MODEL	MAX WATTAGE	FIXTURE VOLTAGE (CV)	LAMP TYPE	POWER SUPPLY INPUT VOLTAGE (V AC)	POWER SUPPLY WATTAGE (W)	POWER SUPPLY INPUT CURRENT (typ.)	POWER SUPPLY POWER FACTOR (typ.)	FIXTURE WEIGHT (KG)	EARTH IN CANOPY
P1.450	27	24	LED STRIP	127 @ 60Hz	60	0.8A/127VAC	PF≥0.97/127VAC	7	YES
				220 @ 60Hz		0.4A/230VAC	PF≥0.95/220VAC		
P1.600	36	24	LED STRIP	127 @ 60Hz	60	0.8A/127VAC	PF≥0.97/127VAC	9	YES
				220 @ 60Hz		0.4A/230VAC	PF≥0.95/220VAC		
P1.900	54	24	LED STRIP	127 @ 60Hz	100	1.2A/127VAC	PF≥0.98/127VAC	14	YES
				220 @ 60Hz		0.55A/230VAC	PF≥0.95/220VAC		
P1.1200	72	24	LED STRIP	127 @ 60Hz	100	1.2A/127VAC	PF≥0.98/127VAC	19	YES
				220 @ 60Hz		0.55A/230VAC	PF≥0.95/220VAC		
P1.1500	90	24	LED STRIP	127 @ 60Hz	150	1.7A/127VAC	PF≥0.98/127VAC	23	YES
				220 @ 60Hz		0.75A/230VAC	PF≥0.95/220VAC		
P1.1800	108	24	LED STRIP	127 @ 60Hz	150	1.7A/127VAC	PF≥0.98/127VAC	28	YES
				220 @ 60Hz		0.75A/230VAC	PF≥0.95/220VAC		
P1.2100	126	24	LED STRIP	127 @ 60Hz	150	1.7A/127VAC	PF≥0.98/127VAC	33	YES
				220 @ 60Hz		0.75A/230VAC	PF≥0.95/220VAC		

- 1 Wearing gloves, unpack the 24V DC POWER CABLE & SUSPENSION WIRES attached to the PENDANT.

Next unpack the supplied CEILING CANOPY (Illustrations may differ to supplied canopy).

Do not unwrap the PENDANT, in order to prevent any damage that may occur during installation.

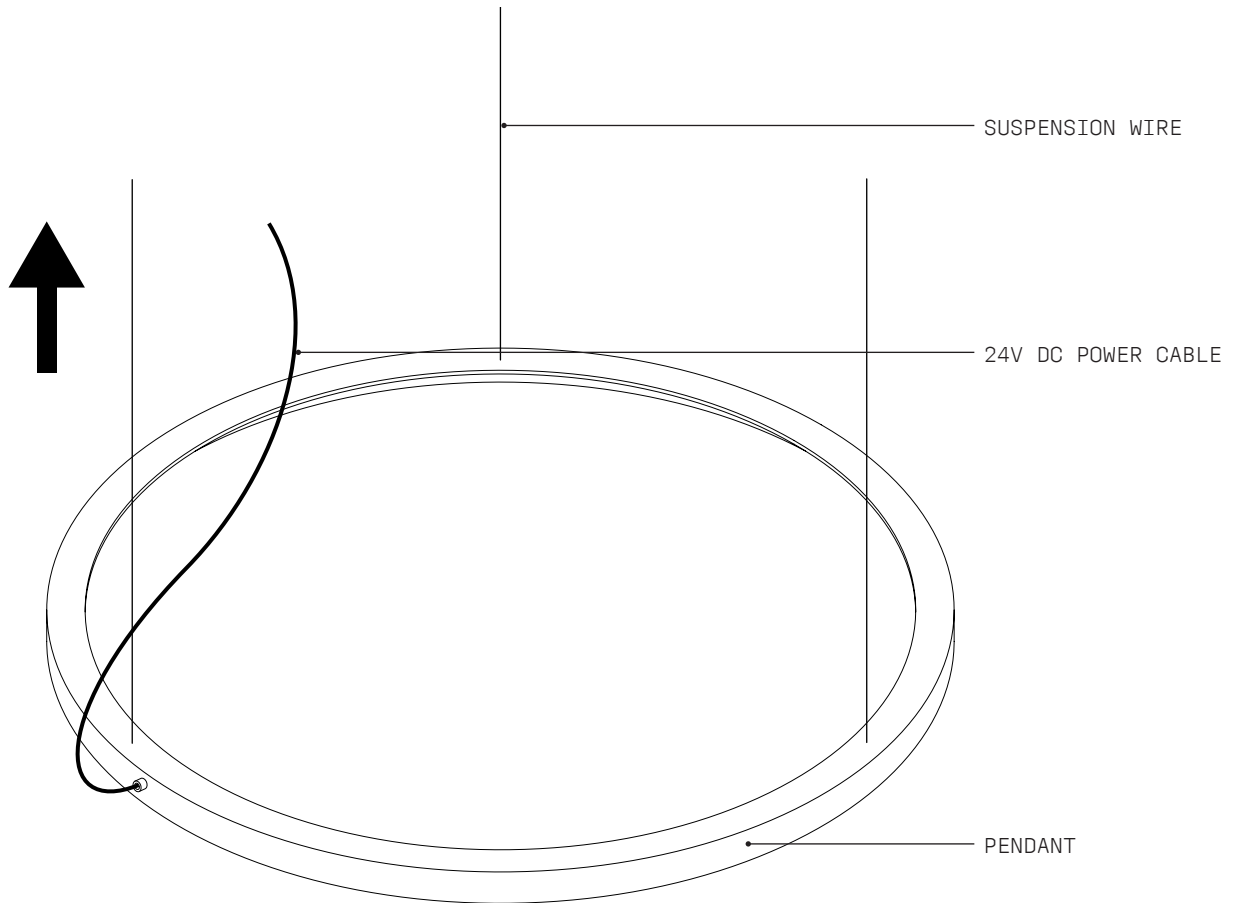

- 2 Ensure that the PENDANT is the right way up as per diagram and that the SUSPENSION WIRES are not tangled.
Feed the 24V DC POWER CABLE and SUSPENSION WIRES through their corresponding positions in the escutcheon and the pendant suspension block, as per supplied CANOPY INSTALLATION GUIDE.

- 3 — Connect the 24V DC POWER CABLE from the PENDANT to supplied POWER SUPPLY UNIT. Refer to supplied WIRING DIAGRAM →



- 4 — Refer to the CANOPY INSTALLATION GUIDE to correctly install all canopy components.

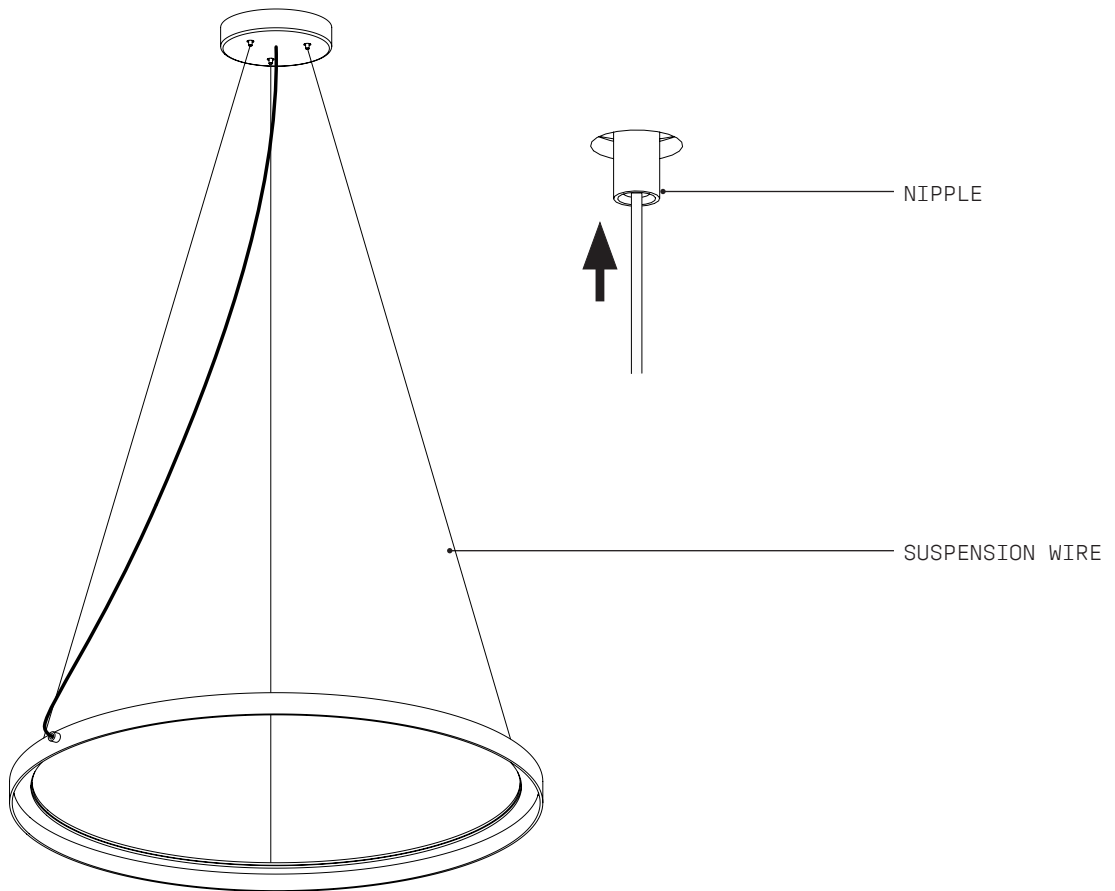

- 5 — Adjust the level of the fixture using the adjustable CABLE GLIDERS. The lengths of the SUSPENSION WIRES can be adjusted to be lower by taking the weight off the suspension wire, and pushing on the spring loaded NIPPLE on the CABLE GLIDER to release.

Remember to always support the fixture during this process. Once settled on the level of the fixture, remove any remaining protective packaging.

- 6 — Unpack the MAGNETISED CRYSTALS straight from the box onto the MAGNETIC SURFACE of the ring. Begin placing them from any chosen SUSPENSION WIRE.

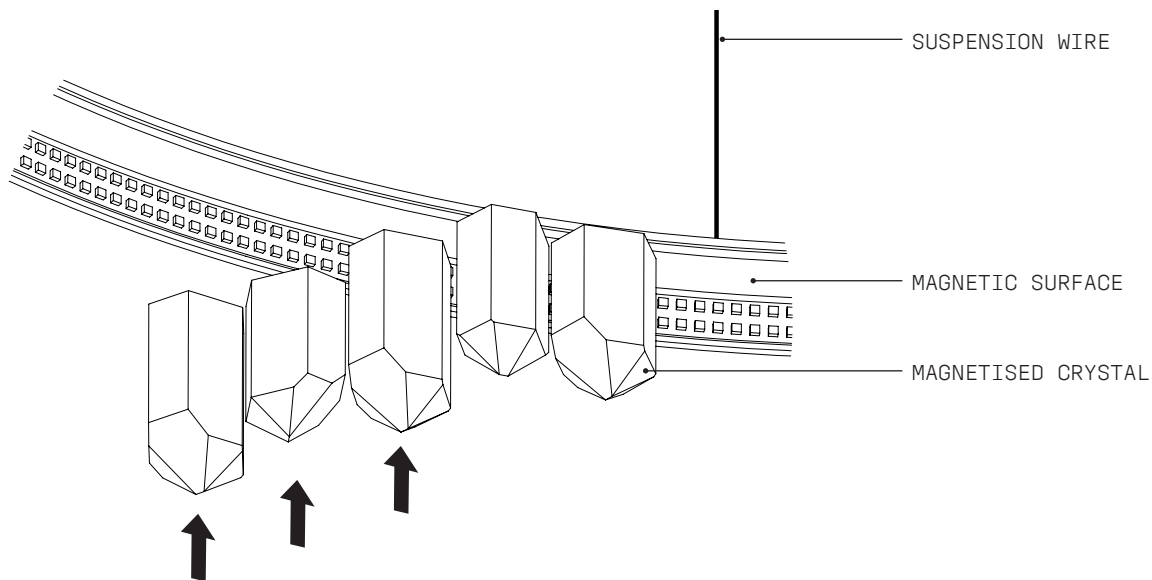

- 7 — Ensure that the MAGNET on the crystal makes full contact with the MAGNETIC SURFACE on the ring.

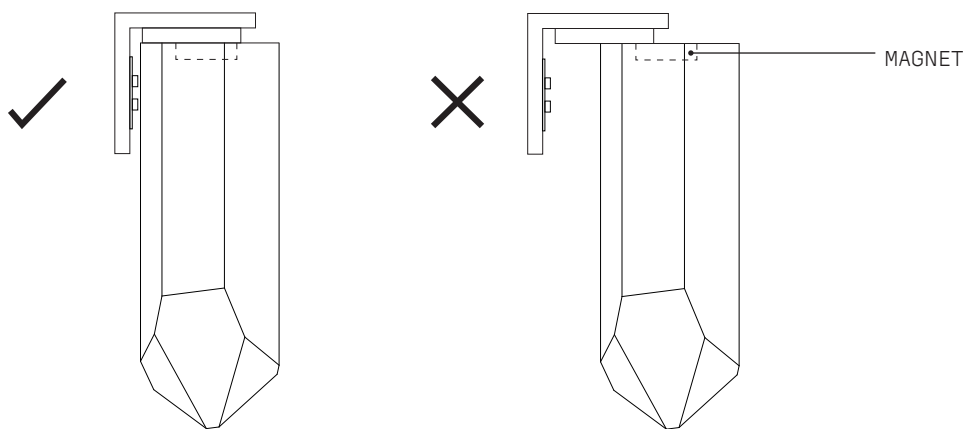

- 8
- Rotate magnetised crystals until the magnet makes full contact with magnetic surface.
 - Pack the crystals onto the ring tightly, without overlapping. Cover as much visible LED as possible.
 - If crystal selection does not fit as desired, there are spare crystals to use in place of others.

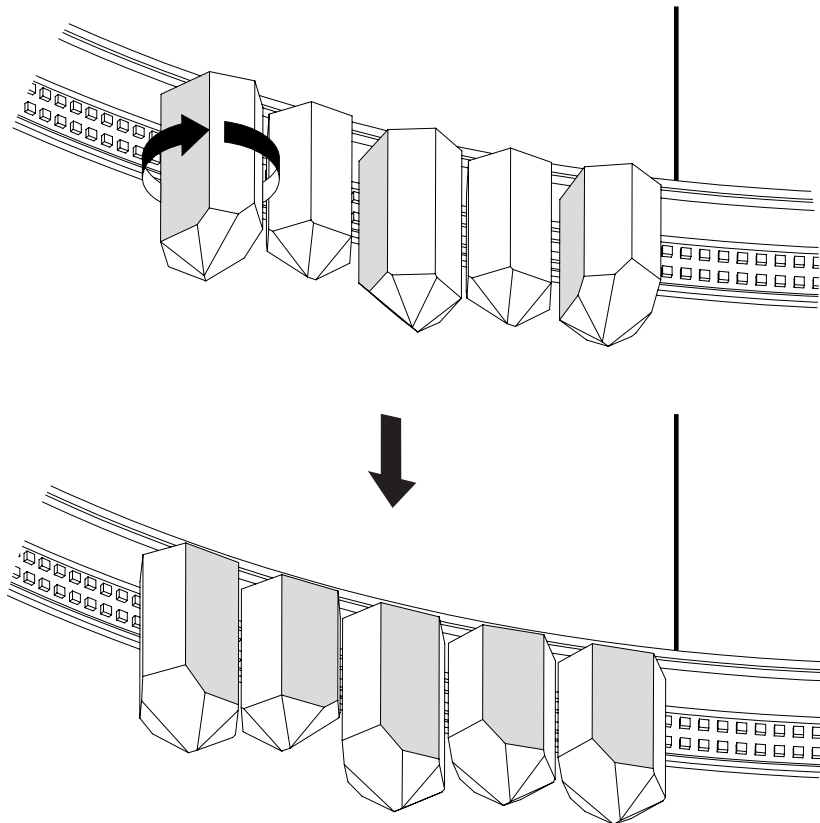

- 9
- Some MAGNETS are not central to the crystal. Rotate the crystal so each MAGNET sits closest to the RING. It is normal if a small portion of the crystal is hanging over the edge of the ring.

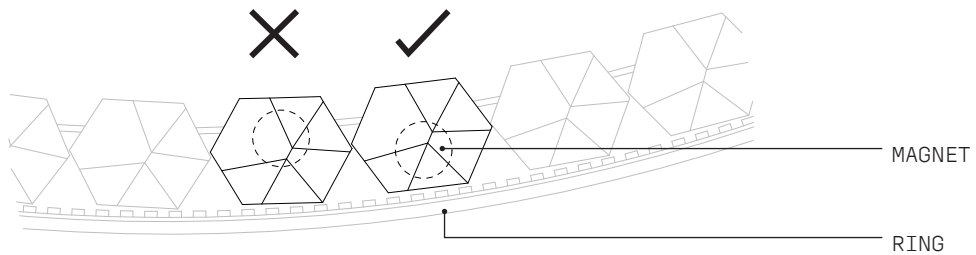

- 10 — Weight and arrangement of crystals may cause the pendant to become unbalanced. Check that the pendant is still level, and re-adjust if necessary, following instructions from Step. 5

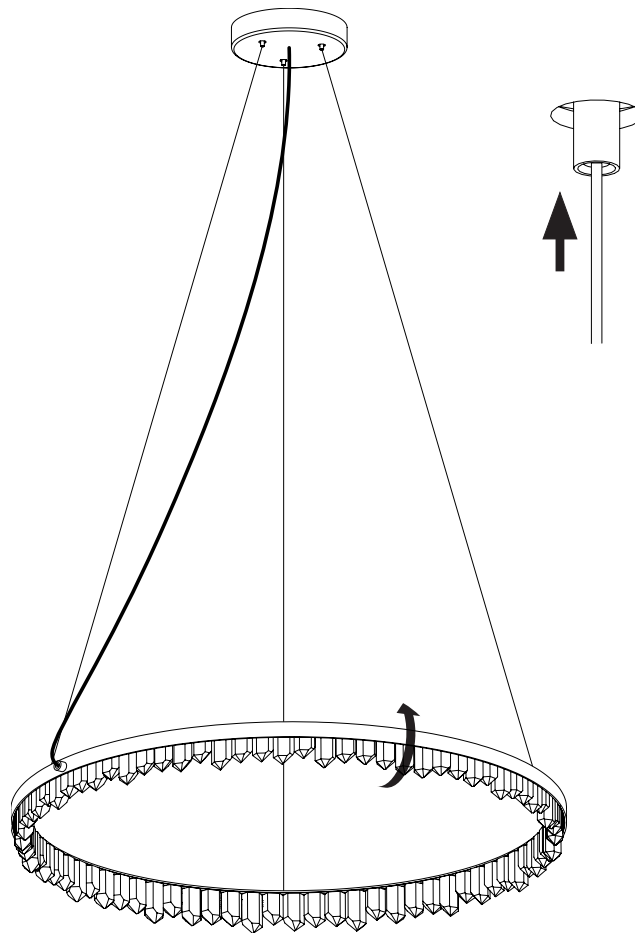

- 11 — Conduct a final visual assessment of the fixture to ensure all parts have been properly fitted and secured. Once satisfied that everything is in working order, the installation process is complete.

FINISH

The PROMETHEUS PENDANT is for indoor use only and operable to a maximum ambient temperature of 60° celsius. The lamping of this luminaire, is a non-user replaceable source and must only be replaced by CHRISTOPHER BOOTS, an appointed agent and/or qualified professional of CHRISTOPHER BOOTS. Should your pendant require relamping, please contact CHRISTOPHER BOOTS by sending an email to sales@christopherboots.com to make the necessary arrangements.



THE LIGHT SOURCE CONTAINED IN THIS LUMINAIRE SHALL ONLY BE REPLACED BY THE MANUFACTURER OR THEIR REPRESENTATIVE AGENT OR A SIMILAR QUALIFIED PERSON

CARE INSTRUCTIONS:

PROMETHEUS is a solid fixture that will require very little maintenance over the years, however changes in appearance of hand applied finishes or unlacquered finishes will vary as these (finishes) are designed to age in appearance. If your PROMETHEUS is treated with care, it will shine brightly for many years to come. We recommend some general tips to help keep it shining its brightest:

- Remove dust by simply running an electrostatic duster or dry cloth every few weeks over all exposed surfaces.
- Under no circumstances should the fixture be cleaned with any type of liquids/detergents or solvents.
- If more than dusting is required, please contact us at:
sales@christopherboots.com
- We recommend the use of micro fibre cloths.

WARRANTY

1. CHRISTOPHER BOOTS offers a 36 month / 3 year warranty from date of receipt of balance payment on all light fittings supplied (not installation) against mechanical defects.
2. CHRISTOPHER BOOTS will repair or replace defective components or product within this warranty period.
3. Warranty for componentry includes:
4. LED lamps and strips: 3 years / 36 months after receipt.
5. LED POWER SUPPLYs 60w: 3 years / 36 months after receipt.
6. LED POWER SUPPLYs 100w + 150w: 5 years / 60 months after receipt.
7. If unsure, please contact sales@christopherboots.com

Christopher Boots will not be held responsible for the following:

1. Damage caused by improper cleaning solutions or methods.
2. Damage caused by improper installation or assembly by customer or customer's agent.
3. Damage caused by improper use of LED:
4. Damage caused by exposure to weather or improper environment – client to check IP rating prior to purchase.
5. Changes in appearance of hand applied finishes or unlacquered finishes.
*Please note that these finishes are designed to age in appearance.
6. Any costs of installation, removal, or re-installation.
7. Restoration, repair work & any parts purchased separately from supplied light fixtures.
8. Damage caused during shipping – all items are packed specifically for global transport.

DAMAGES

1. Damages must be documented and reported within 7 business days of receipt.
2. Photo evidence will be required upon reporting of damage claim.
3. CHRISTOPHER BOOTS is not responsible for repair or replacement of damages reported after this time.
4. If damage has occurred in shipping – all packaging must be retained by receiver. Failure to do so may invalidate any claim.

RETURNS

1. Because of the hand-made nature of our product, we are not able to offer returns.
2. Warranty claims, however will require client to cover shipping enroute back for repair

A. DEFINITIONS

In this warranty Australian Consumer Law means the Australian consumer law set out in Schedule 2 to the Competition and Consumer Act 2010.

Goods means the product or equipment that was purchased in Australia and listed in the Applicable Product Ranges below.

Manufacturer, We or Us means:
CHRISTOPHER BOOTS Pty Ltd
ABN 20 161 794 574

Supplier means the authorized distributor or the licensed electrical contractor that sold you the Goods.

You means you, the original end-user purchaser of the Goods.

B. WARRANTY PERIOD AND DETAILS

The products detailed above are covered by a warranty against manufacturing faults and defects, provided that:

The product is properly installed, and installation is consistent with the manufacturer's instructions, and is installed by suitably trained and qualified installer. The product is not subjected to any unauthorised modifications.

The product is only used for the purpose of decorative illumination, in line with its designated purpose.

The product use is in normal conditions.

Any faults or defects attributable to the misuse, abuse, accident or non-observance of the manufacturer's instructions on the part of the user are specifically excluded.

C. EXTENT OF THE WARRANTY

GOODS that prove defective within the Warranty Period by reason or improper workmanship or faulty material, we may, at our own discretion, either repair or replace the GOODS without charge.

This warranty does not cover any cost related to removal, shipping to or from the return point, or reinstallation of the replace or repair item.

Any parts of the GOODS replaced during repairs or any product replaced remain the property of CHRISTOPHER BOOTS Pty Ltd.

In the event of the GOODS being replaced during the WARRANTY PERIOD, the warranty on the replacement GOODS will expire on the same date as the WARRANTY PERIOD of the original GOODS they are replacing.

D. APPLICABLE DATE/COMMENCEMENT OF WARRANTY

This warranty commences from the date of purchase from the point of purchase from CHRISTOPHER BOOTS Pty Ltd. The details of the point of purchase, as well as all contact information for warranty claims and queries, are detailed below;

CHRISTOPHER BOOTS Pty Ltd.
369 Gore St. Fitzroy, Vic. Australia 3065
Ph: +61 3 9417 6501
Email: sales@christopherboots.com

E. CLAIM PROCESS

The customer claim process is as follows; The customer can make a claim, or enquire about the claim process, by contacting the company as detailed above.

The customer must provide a proof of purchase from the SUPPLIER.

Before returning any goods for a warranty claim, the customer must obtain authorization and a Goods Return Authorisation (GRA) notice. The customer, at their own expense, then forwards the goods, clearly marked with the GRA notice and with provision for return freight, to CHRISTOPHER BOOTS Pty Ltd (see above).

Upon receipt of the goods, CHRISTOPHER BOOTS Pty Ltd will review the claim, and proof of purchase.

If accepted as a valid warranty claim within the terms as described in this document, CHRISTOPHER BOOTS Pty Ltd will either make suitable repairs or provide an equivalent replacement product.

If the claim is rejected, the customer will be provided with a full explanation, and if requested, the goods will be returned.

IMPORTANT:

Our goods come with guarantees that cannot be excluded under the Australian Consumer Law. You are entitled to a replacement or refund for a major failure and for compensation for any other reasonably foreseeable loss or damage. You are also entitled to have the goods repaired or replaced if the goods fail to be of acceptable quality and the failure does not amount to a major failure.

PROMETHEUS II

ROUND CANOPY + CABLER GLIDER MOUNTS VERTICAL SUSPENSION

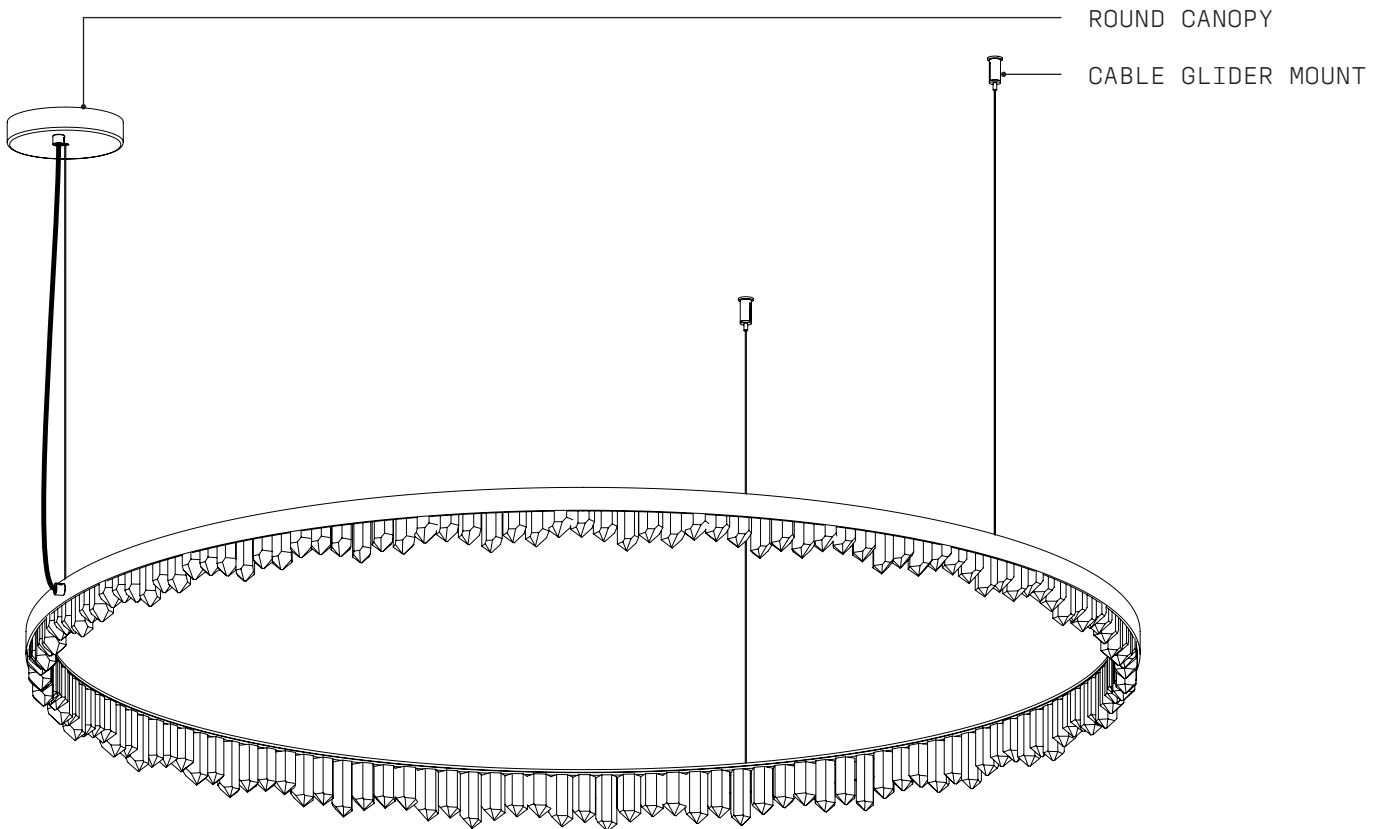

WARNING

ALL ELECTRICAL CONNECTIONS MUST BE MADE BY A QUALIFIED ELECTRICIAN IN ACCORDANCE WITH THE REGULATIONS AND CODES GOVERNING THE AREA FOR WHICH THE CHRISTOPHER BOOTS FIXTURE IS INTENDED TO BE INSTALLED IN. FAILURE TO DO SO MAY RESULT IN SERIOUS HARM OR DAMAGE TO PROPERTY AND LIFE, AT THE OWNER'S LIABILITY AND EXPENSE. CHRISTOPHER BOOTS WILL NOT BE HELD LIABLE FOR ANY DAMAGE CAUSED FROM INSTALLATION.





WARNING: SHOCK HAZARD

May result in serious injury or death.
ENSURE POWER IS OFF before commencing any work.



WARNING: ELECTRICAL

ALL ELECTRICAL connections must be made by a qualified electrician in accordance with the regulations and codes governing the area for which the CHRISTOPHER BOOTS Fixture is intended to be installed in. Failure to do so may result in serious harm or damage to property and life, at the owner’s liability and expense.

CHRISTOPHER BOOTS will not be held liable for any damage caused from installation.



WARNING: STRUCTURAL

Ensure that the substrate is securely installed and is in accordance with local building regulations. Failure to do so may potentially result in serious harm or damage of property, at the owner’s liability and expense.

CHRISTOPHER BOOTS will not be held liable for any damage caused from installation.

Refer to supplied WIRING DIAGRAM. →



TECHNICAL INFORMATION									
MODEL	MAX WATTAGE	FIXTURE VOLTAGE (CV)	LAMP TYPE	POWER SUPPLY INPUT VOLTAGE (V AC)	POWER SUPPLY WATTAGE (W)	POWER SUPPLY INPUT CURRENT (typ.)	POWER SUPPLY POWER FACTOR (typ.)	FIXTURE WEIGHT (KG)	EARTH IN CANOPY
P2.450	27	24	LED STRIP	100-120 @ 60Hz	60	0.8A/115VAC	PF≥0.97/115VAC	7	YES
				220-240 @ 50Hz		0.4A/230VAC	PF≥0.95/230VAC		
P2.600	36	24	LED STRIP	100-120 @ 60Hz	60	0.8A/115VAC	PF≥0.97/115VAC	9	YES
				220-240 @ 50Hz		0.4A/230VAC	PF≥0.95/230VAC		
P2.900	54	24	LED STRIP	100-120 @ 60Hz	100	1.2A/115VAC	PF≥0.98/115VAC	14	YES
				220-240 @ 50Hz		0.55A/230VAC	PF≥0.95/230VAC		
P2.1200	72	24	LED STRIP	100-120 @ 60Hz	100	1.2A/115VAC	PF≥0.98/115VAC	19	YES
				220-240 @ 50Hz		0.55A/230VAC	PF≥0.95/230VAC		
P2.1500	90	24	LED STRIP	100-120 @ 60Hz	150	1.7A/115VAC	PF≥0.98/115VAC	23	YES
				220-240 @ 50Hz		0.75A/230VAC	PF≥0.95/230VAC		
P2.1800	108	24	LED STRIP	100-120 @ 60Hz	150	1.7A/115VAC	PF≥0.98/115VAC	28	YES
				220-240 @ 50Hz		0.75A/230VAC	PF≥0.95/230VAC		
P2.2100	126	24	LED STRIP	100-120 @ 60Hz	150	1.7A/115VAC	PF≥0.98/115VAC	33	YES
				220-240 @ 50Hz		0.75A/230VAC	PF≥0.95/230VAC		

- 1 Wearing gloves, unpack POWER CABLE & SUSPENSION WIRES attached to the fixture.
Next unpack the ROUND CANOPY.
Do not unwrap the PENDANT, in order to prevent any damage that may occur during installation.

- 2 Ensure PENDANT is the right way up and SUSPENSION WIRES are not tangled.

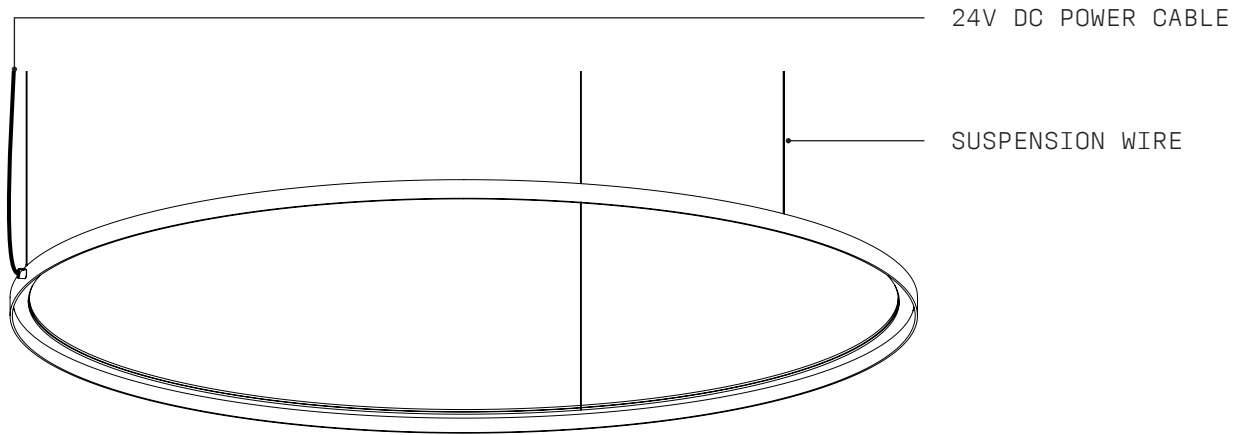

- 3 Refer to SET-OUT DOCUMENT and prepare ROUND CANOPY and CABLE GLIDER MOUNTS with their respective INSTALLATION GUIDES.
Installer to provide adequate load-bearing substrate, utilising studs where additional support is required. Due to the fixture being made by hand, all dimensions should be used as a guide only.

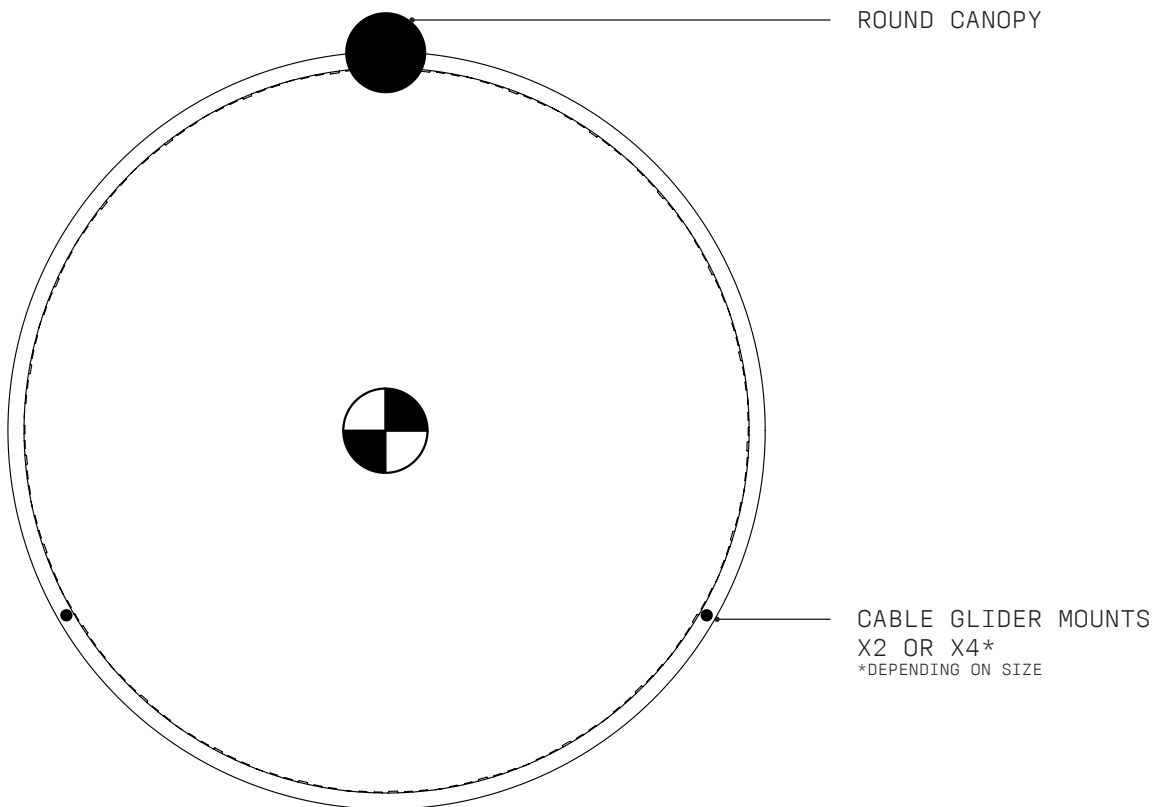

- 4 Wearing gloves, unpack QUARTZ CRYSTALS straight from the box onto WHITE MAGNETIC SURFACE of PENDANT.
- Start packing QUARTZ CRYSTALS onto PENDANT at 3 points, beginning at SUSPENSION WIRES.
- This will ensure the weight of QUARTZ CRYSTALS do not overload the fixture at any point.

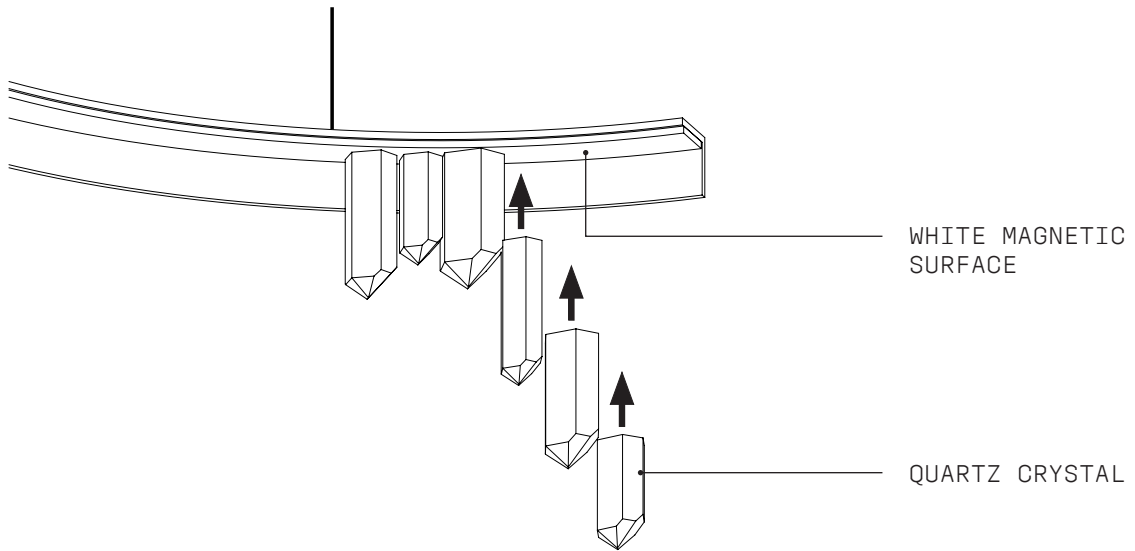

Ensure MAGNET on QUARTZ CRYSTAL makes full contact with WHITE MAGNETIC SURFACE on PENDANT.

This may mean rotating the QUARTZ CRYSTAL until MAGNET makes full contact.

Place QUARTZ CRYSTALS onto PENDANT tightly, without overlapping.

Cover as much of the visible LED as possible.

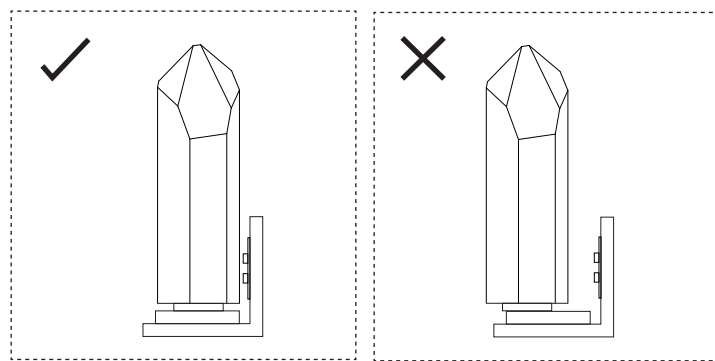

- 5 Conduct a final visual assessment of PROMETHEUS I to ensure proper fitting.
- Once satisfied everything is in working order, installation is complete.
- Please dispose of packaging material thoughtfully.
- PROMETHEUS I is a solid fixture requiring very little maintenance over the years. Changes in appearance of hand applied unlacquered finishes will vary as they are designed to age in appearance.
- If your PROMETHEUS I is treated with care, it will shine brightly for many years to come.

CARE INSTRUCTIONS

- PROMETHEUS II is for indoor use only and operable to a maximum ambient temperature of 25° Celsius. The lamping of this luminaire, is a non-user replaceable source and must only be replaced by CHRISTOPHER BOOTS, an appointed agent and/or qualified professional of CHRISTOPHER BOOTS. Should your pendant require relamping, please contact sales@christopherboots.com to make necessary arrangements.
- Remove dust by simply running an electrostatic duster or dry cloth every few weeks over all external surfaces.
- Take particular care when dusting internal surfaces as these are extremely delicate. A clean lint-free cloth will be ample.
- Crystals are attached with rare-earth magnets: they can easily be removed from the fixture for polishing with a dry micro-fibre cloth.
- Under no circumstances should the fixture be cleaned with any type of liquids/detergents or solvents.
- We recommend using micro fibre cloths.
- If more than dusting is required, please contact us at: sales@christopherboots.com

WARRANTY

1. Christopher Boots offers a 36 month / 3 year warranty from date of receipt of balance payment on all light fittings supplied (not installation) against mechanical defects.
2. Christopher Boots will repair or replace defective components or product within this warranty period.
3. Warranty for components includes:
4. LED lamps and strips: 3 years / 36 months after receipt.
5. LED drivers 60w: 3 years / 36 months after receipt.
6. LED drivers 100w + 150w: 5 years / 60 months after receipt.
7. Incandescent lamps: no warranty – no manufacturer warrants filament lamps.
8. Fixtures are clearly labeled with maximum allowable wattage therefore responsibility of installer / end client to ensure correct lamps & wattages are compliant.
9. Use of higher wattage bulbs than indicated will forfeit warranty.
10. Warranty claims require client to cover shipping enroute back for repair.
11. Any questions? Contact sales@christopherboots.com

CHRISTOPHER BOOTS WILL NOT BE HELD RESPONSIBLE FOR THE FOLLOWING

1. Damage caused by improper cleaning solutions or methods.
2. Damage caused by improper installation or assembly by customer or customer's agent.
3. Damage caused by improper use of light bulbs.
4. Where applicable, installers ensure screwing lamps / glass lamp cover inline with trajectory of product branch + lampholder upon lamp replacement.
5. Where applicable, a screwing motion of slightest angle may cause cross-threading & breakage not covered under warranty.
6. Damage caused by exposure to weather or improper environment – client to check IP rating prior to purchase.
7. Changes in appearance of hand applied finishes or unlacquered finishes.
8. Please note that finishes are designed to age in appearance.
9. Any costs of installation, removal, or re-installation.
10. Restoration, repair work & any parts purchased separately from supplied light fixtures.
11. Damage caused during shipping. All items are packed specifically for global transport.

DAMAGES

1. Damages must be documented and reported within 7 business days of receipt.
2. If external flexible cable of this luminaire is damaged, it shall be exclusively replaced by the manufacturer or your service agent in order to avoid hazard.
3. Photo evidence will be required upon reporting of damage claim.
4. Christopher Boots is not responsible for repair or replacement of damages reported after this time.
5. If damage has occurred in shipping, all packaging must be retained by receiver. Failure to do so may invalidate any claim.

RETURNS

1. Because of the hand-made nature of our product, we unable to offer returns.