

PROMETHEUS IV

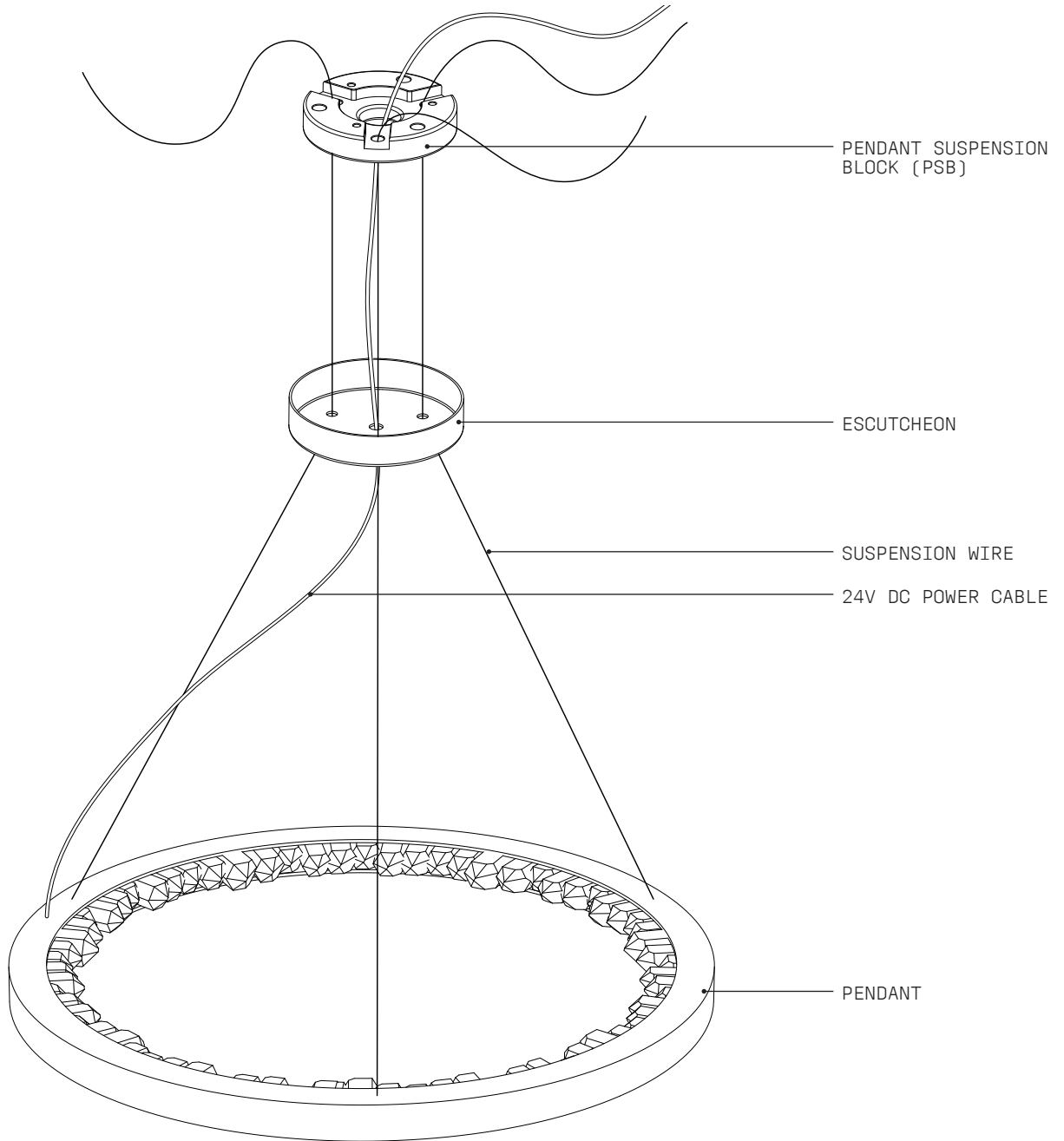

WARNING

ALL ELECTRICAL CONNECTIONS MUST BE MADE BY A QUALIFIED ELECTRICIAN IN ACCORDANCE WITH THE REGULATIONS AND CODES GOVERNING THE AREA FOR WHICH THE CHRISTOPHER BOOTS FIXTURE IS INTENDED TO BE INSTALLED IN. FAILURE TO DO SO MAY RESULT IN SERIOUS HARM OR DAMAGE TO PROPERTY AND LIFE, AT THE OWNER'S LIABILITY AND EXPENSE. CHRISTOPHER BOOTS WILL NOT BE HELD LIABLE FOR ANY DAMAGE CAUSED FROM INSTALLATION.



**WARNING:
SHOCK HAZARD**

May result in serious injury or death.
ENSURE POWER IS OFF before commencing any work.



**WARNING:
ELECTRICAL**

ALL ELECTRICAL connections must be made by a qualified electrician in accordance with the regulations and codes governing the area for which the CHRISTOPHER BOOTS Fixture is intended to be installed in. Failure to do so may result in serious harm or damage to property and life, at the owner’s liability and expense.

CHRISTOPHER BOOTS will not be held liable for any damage caused from installation.



**WARNING:
STRUCTURAL**

Ensure that the substrate is securely installed and is in accordance with local building regulations. Failure to do so may potentially result in serious harm or damage of property, at the owner’s liability and expense.

CHRISTOPHER BOOTS will not be held liable for any damage caused from installation.

Refer to supplied WIRING DIAGRAM.



MODEL	WATTAGE	LAMP TYPE	POWER SUPPLY UNIT (W)	POWER SUPPLY UNIT (V)	WEIGHT (KG)	EARTHING FEATURE (CANOPIES)
P4.450	28	LED	60	24	6.75	YES
P4.600	37	LED	60	24	9	YES
P4.900	55	LED	100	24	13.5	YES
P4.1200	73	LED	100	24	18	YES
P4.1500	91	LED	150	24	22.5	YES
P4.1800	109	LED	150	24	27	YES
P4.2100	127	LED	150	24	31.5	YES

- 1 Wearing gloves, unpack the 24V DC POWER CABLE & SUSPENSION WIRES attached to the PENDANT.

Next unpack the supplied CEILING CANOPY (Illustrations may differ to supplied canopy).

Do not unwrap the PENDANT, in order to prevent any damage that may occur during installation.

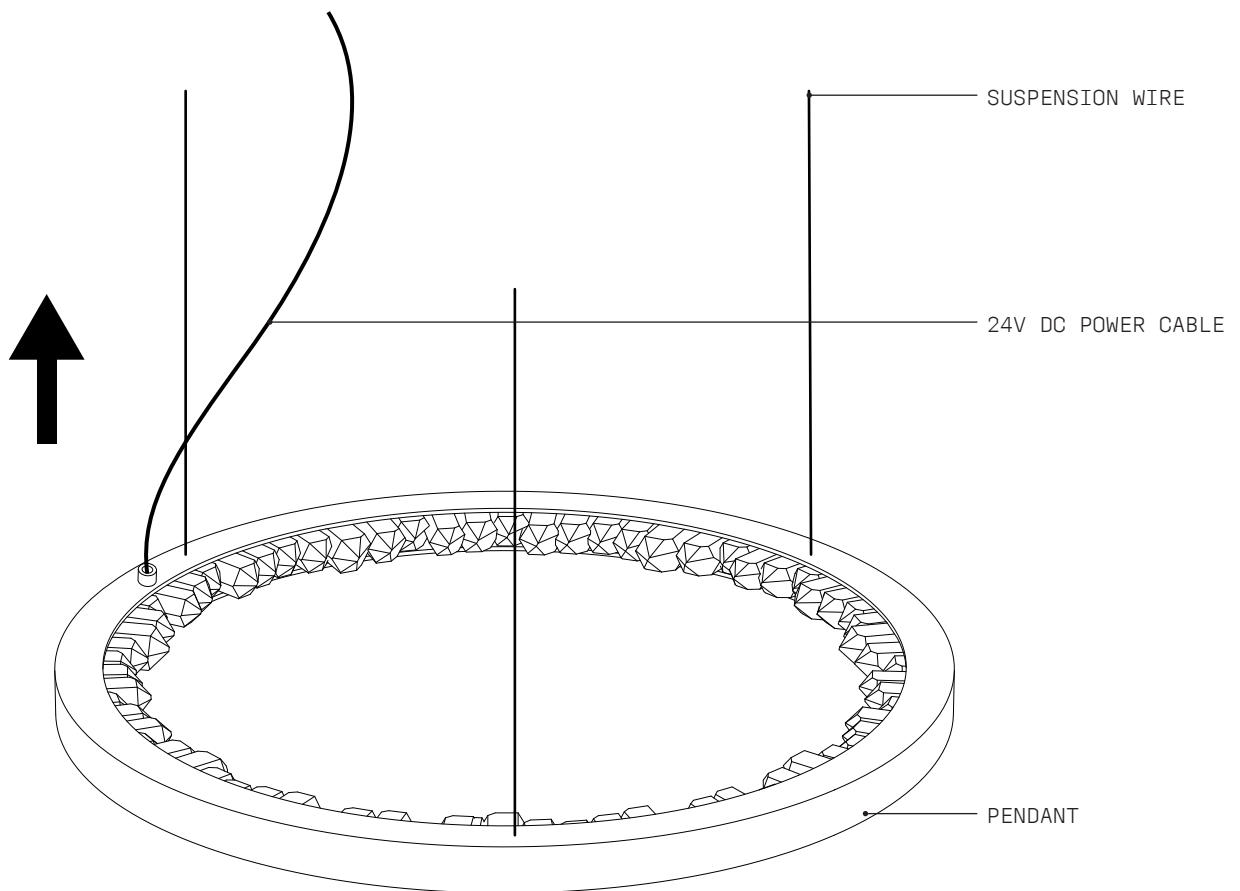

- 2 Ensure that the PENDANT is the right way up as per diagram and that the SUSPENSION WIRES are not tangled.
Feed the 24V DC POWER CABLE and SUSPENSION WIRES through their corresponding positions in the escutcheon and the pendant suspension block, as per supplied CANOPY INSTALLATION GUIDE.

- 3 Connect the 24V DC POWER CABLE from the PENDANT to supplied POWER SUPPLY UNIT.
 — Refer to supplied WIRING DIAGRAM →



- 4 Refer to the CANOPY INSTALLATION GUIDE to correctly install all canopy components.

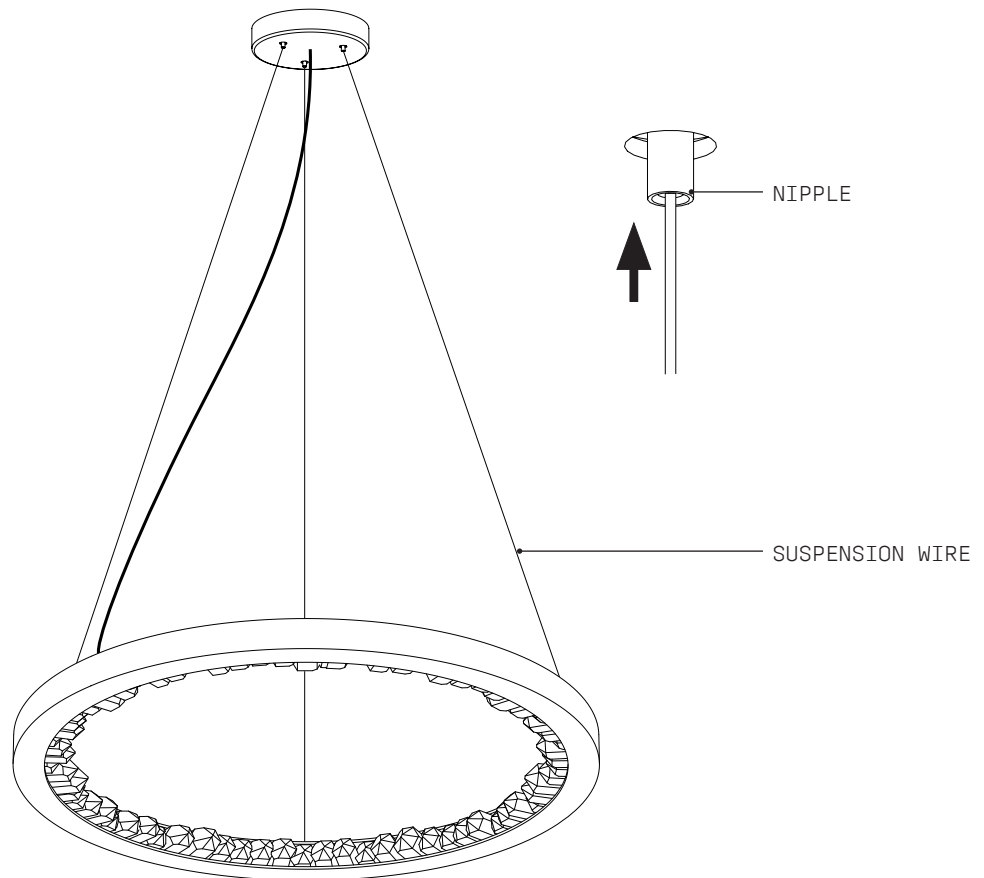

- 5 Adjust the level of the fixture using the adjustable CABLE GLIDERS. The lengths of the SUSPENSION WIRES can be adjusted to be lower by taking the weight off the suspension wire, and pushing on the spring loaded NIPPLE on the CABLE GLIDER to release.

Remember to always support the fixture during this process. Once settled on the level of the fixture, remove any remaining protective packaging.

FINISH

CARE INSTRUCTIONS

- PROMETHEUS III is for indoor use only and operable to a maximum ambient temperature of 60° Celsius. The lamping of this luminaire, is a non-user replaceable source and must only be replaced by CHRISTOPHER BOOTS, an appointed agent and/or qualified professional of CHRISTOPHER BOOTS. Should your pendant require relamping, please contact sales@christopherboots.com to make necessary arrangements.
- Remove dust by simply running an electrostatic duster or dry cloth every few weeks over all external surfaces.
- Take particular care when dusting internal surfaces as these are extremely delicate. A clean lint-free cloth will be ample.
- Crystals are attached with rare-earth magnets: they can easily be removed from the fixture for polishing with a dry micro-fibre cloth.
- Under no circumstances should the fixture be cleaned with any type of liquids/detergents or solvents.
- We recommend using micro fibre cloths.
- If more than dusting is required, please contact us at: sales@christopherboots.com

WARRANTY

1. Christopher Boots offers a 36 month / 3 year warranty from date of receipt of balance payment on all light fittings supplied (not installation) against mechanical defects.
2. Christopher Boots will repair or replace defective components or product within this warranty period.
3. Warranty for components includes:
4. LED lamps and strips: 3 years / 36 months after receipt.
5. LED drivers 60w: 3 years / 36 months after receipt.
6. LED drivers 100w + 150w: 5 years / 60 months after receipt.
7. Incandescent lamps: no warranty – no manufacturer warrants filament lamps.
8. Fixtures are clearly labeled with maximum allowable wattage therefore responsibility of installer / end client to ensure correct lamps & wattages are compliant.
9. Use of higher wattage bulbs than indicated will forfeit warranty.
10. Warranty claims require client to cover shipping enroute back for repair.
11. Any questions? Contact sales@christopherboots.com

CHRISTOPHER BOOTS WILL NOT BE HELD RESPONSIBLE FOR THE FOLLOWING

1. Damage caused by improper cleaning solutions or methods.
2. Damage caused by improper installation or assembly by customer or customer's agent.
3. Damage caused by improper use of light bulbs:
4. Installers ensure screwing lamps / glass lamp cover inline with trajectory of product branch + lampholder upon lamp replacement.
5. A screwing motion of slightest angle may cause cross-threading & breakage not covered under warranty.
6. Damage caused by exposure to weather or improper environment – client to check IP rating prior to purchase.
7. Changes in appearance of hand applied finishes or unlacquered finishes.
8. Please note that finishes are designed to age in appearance.
9. Any costs of installation, removal, or re-installation.
10. Restoration, repair work & any parts purchased separately from supplied light fixtures.
11. Damage caused during shipping. All items are packed specifically for global transport.

DAMAGES

1. Damages must be documented and reported within 7 business days of receipt.
2. Photo evidence will be required upon reporting of damage claim.
3. Christopher Boots is not responsible for repair or replacement of damages reported after this time.
4. If damage has occurred in shipping, all packaging must be retained by receiver. Failure to do so may invalidate any claim.

RETURNS

1. Because of the hand-made nature of our product, we unable to offer returns.

PROMETHEUS IV SCONCE

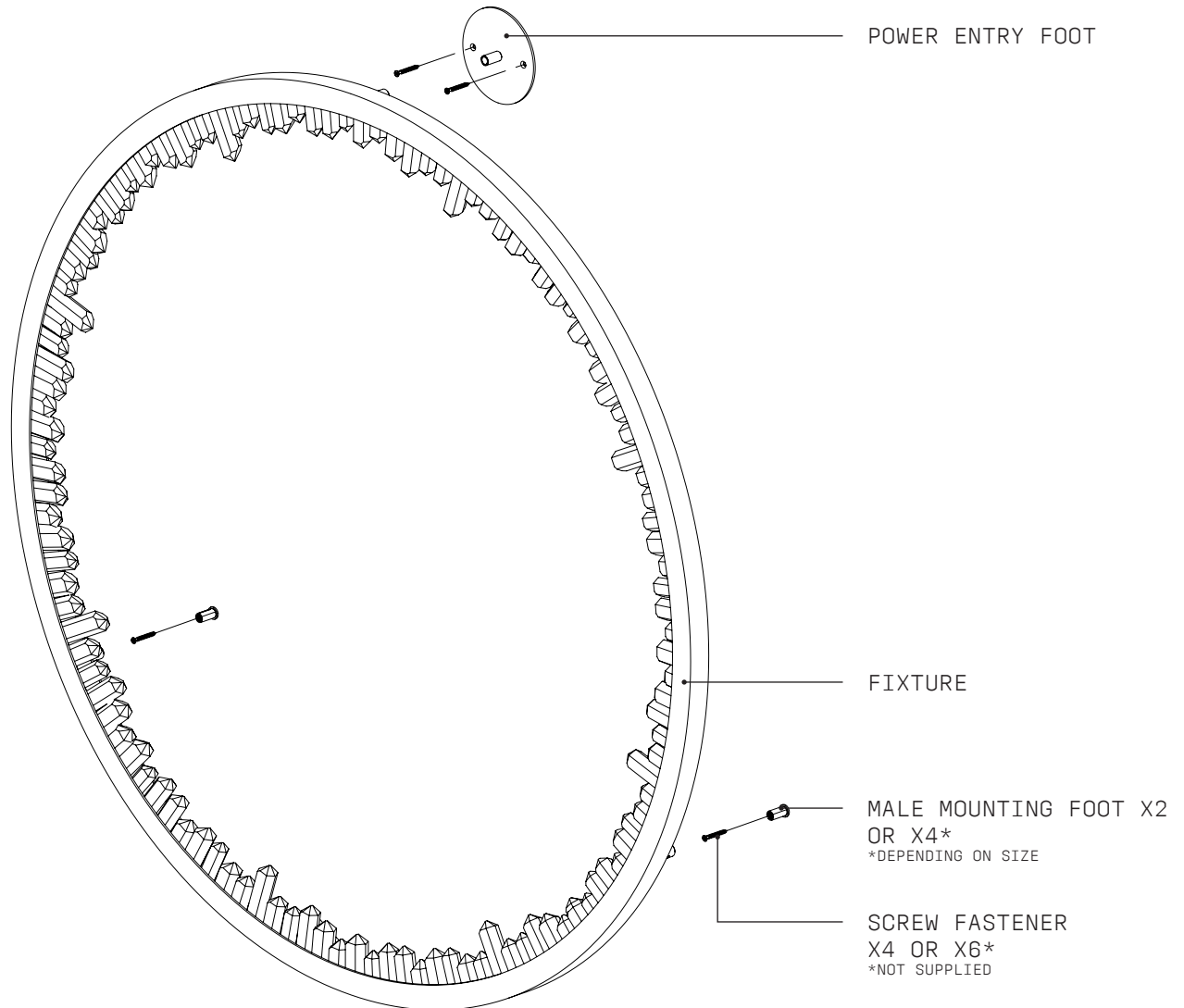

WARNING

ALL ELECTRICAL CONNECTIONS MUST BE MADE BY A QUALIFIED ELECTRICIAN IN ACCORDANCE WITH THE REGULATIONS AND CODES GOVERNING THE AREA FOR WHICH THE CHRISTOPHER BOOTS FIXTURE IS INTENDED TO BE INSTALLED IN. FAILURE TO DO SO MAY RESULT IN SERIOUS HARM OR DAMAGE TO PROPERTY AND LIFE, AT THE OWNER'S LIABILITY AND EXPENSE. CHRISTOPHER BOOTS WILL NOT BE HELD LIABLE FOR ANY DAMAGE CAUSED FROM INSTALLATION.





WARNING: SHOCK HAZARD

May result in serious injury or death.
ENSURE POWER IS OFF before commencing any work.



WARNING: ELECTRICAL

ALL ELECTRICAL connections must be made by a qualified electrician in accordance with the regulations and codes governing the area for which the CHRISTOPHER BOOTS Fixture is intended to be installed in. Failure to do so may result in serious harm or damage to property and life, at the owner’s liability and expense.

CHRISTOPHER BOOTS will not be held liable for any damage caused from installation.



WARNING: STRUCTURAL

Ensure that the substrate is securely installed and is in accordance with local building regulations. Failure to do so may potentially result in serious harm or damage of property, at the owner’s liability and expense.

CHRISTOPHER BOOTS will not be held liable for any damage caused from installation.

Refer to supplied WIRING DIAGRAM. →



TECHNICAL INFORMATION									
MODEL	MAX WATTAGE	FIXTURE VOLTAGE (CV)	LAMP TYPE	POWER SUPPLY INPUT VOLTAGE (V AC)	POWER SUPPLY WATTAGE (W)	POWER SUPPLY INPUT CURRENT (typ.)	POWER SUPPLY POWER FACTOR (typ.)	FIXTURE WEIGHT (KG)	EARTH
P4.W.450	27	24	LED STRIP	100-120 @ 60Hz	60	0.8A/115VAC	PF≥0.97/115VAC	6.75	YES
				220-240 @ 50Hz		0.4A/230VAC	PF≥0.95/230VAC		
P4.W.600	36	24	LED STRIP	100-120 @ 60Hz	60	0.8A/115VAC	PF≥0.97/115VAC	9	YES
				220-240 @ 50Hz		0.4A/230VAC	PF≥0.95/230VAC		
P4.W.900	54	24	LED STRIP	100-120 @ 60Hz	100	1.2A/115VAC	PF≥0.98/115VAC	13.5	YES
				220-240 @ 50Hz		0.55A/230VAC	PF≥0.95/230VAC		
P4.W.1200	72	24	LED STRIP	100-120 @ 60Hz	100	1.2A/115VAC	PF≥0.98/115VAC	18	YES
				220-240 @ 50Hz		0.55A/230VAC	PF≥0.95/230VAC		
P4.W.1500	90	24	LED STRIP	100-120 @ 60Hz	150	1.7A/115VAC	PF≥0.98/115VAC	22.5	YES
				220-240 @ 50Hz		0.75A/230VAC	PF≥0.95/230VAC		
P4.W.1800	108	24	LED STRIP	100-120 @ 60Hz	150	1.7A/115VAC	PF≥0.98/115VAC	27	YES
				220-240 @ 50Hz		0.75A/230VAC	PF≥0.95/230VAC		
P4.W.2100	126	24	LED STRIP	100-120 @ 60Hz	150	1.7A/115VAC	PF≥0.98/115VAC	31.5	YES
				220-240 @ 50Hz		0.75A/230VAC	PF≥0.95/230VAC		

- 1 Wearing gloves, unpack PROMETHEUS IV SCONCE.
Do not unwrap protective wrapping to prevent any damage that may occur during installation.

- 2 Refer to SET-OUT DOCUMENT. Installer to provide adequate load-bearing substrate, utilising studs where additional support is required. Due to the fixture being made by hand, all dimensions should be used as a guide only.

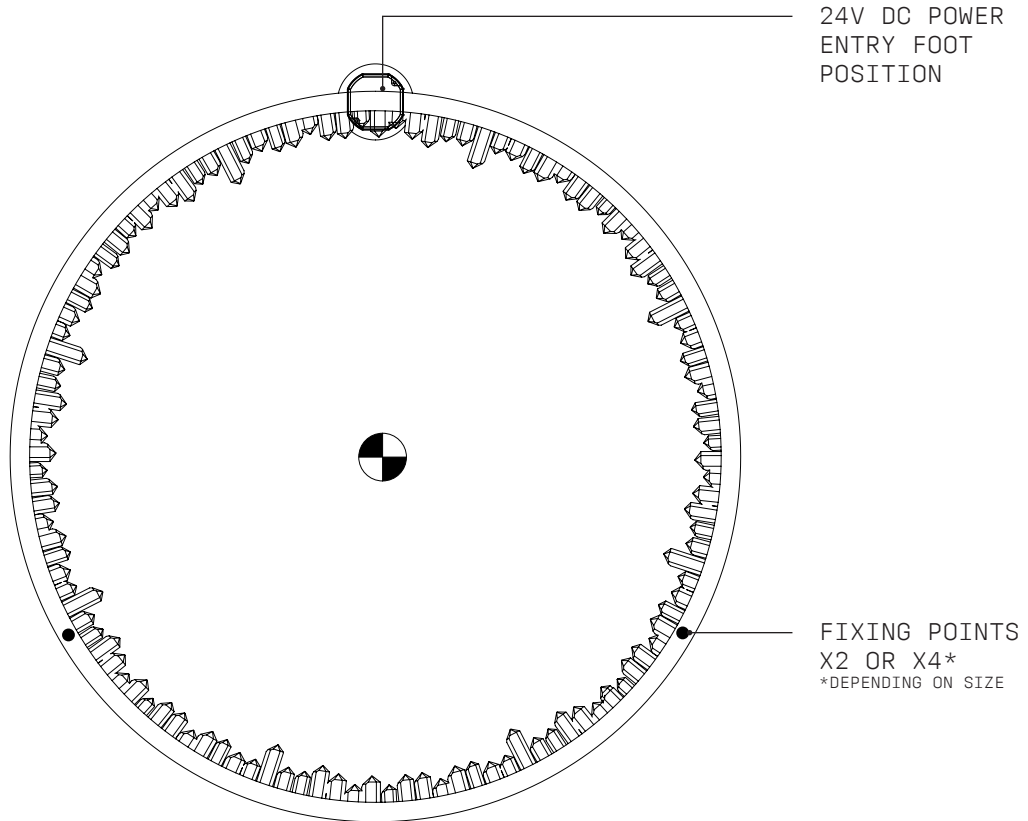

- 3 Installer to feed power supply into wall opening or remotely locate and prepare 24V DC Power Supply for connection to the Sconce. Refer to supplied WIRING DIAGRAM.

Feed SCONCE POWER CABLE through the POWER ENTRY FOOT and connect to the 24V DC POWER CABLE.

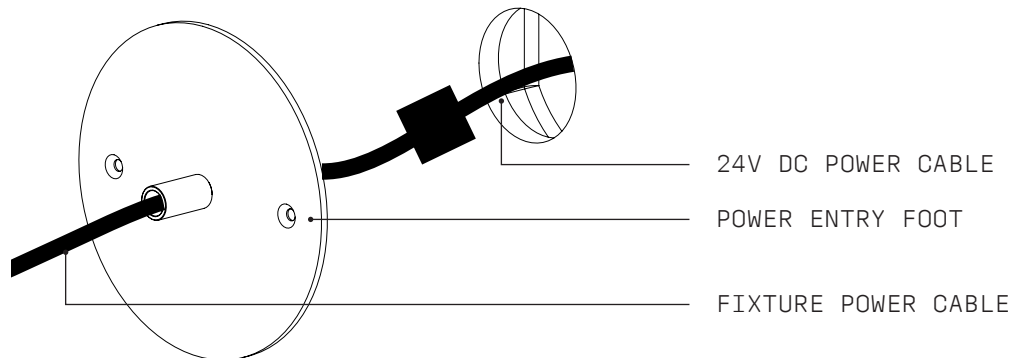

- 4 Attach the POWER ENTRY FOOT and MALE MOUNTING FEET to Substrate with appropriate Fasteners.
NOTE: For accurate positioning of the MALE MOUNTING FEET, use the PROMETHEUS IV SCONCE as a guide.

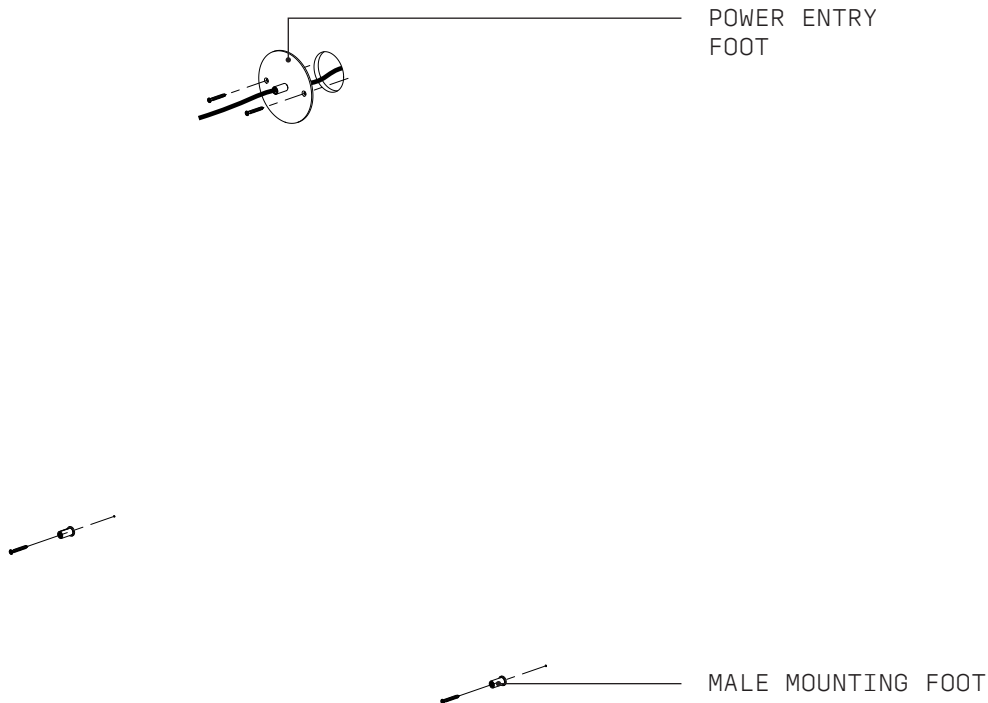

- 5 Feed excess POWER CABLE into the wall and attach the PROMETHEUS Sconce to the POWER ENTRY FOOT and MALE MOUNTING FEET.

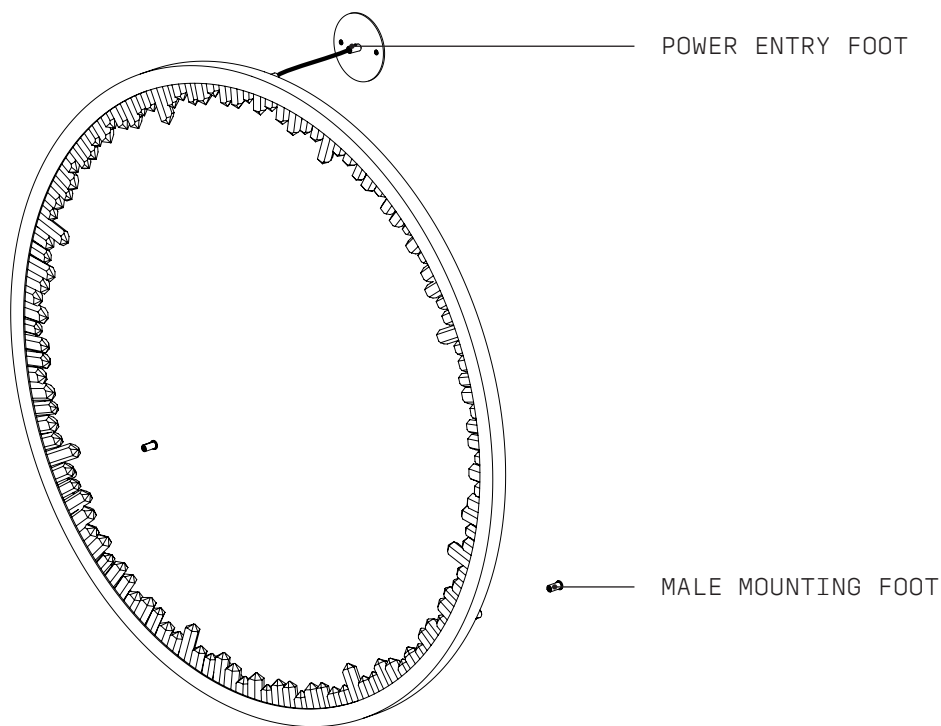

6 Tightly fasten all GRUB SCREWS located on the FEMALE MOUNTING SLEEVE's.

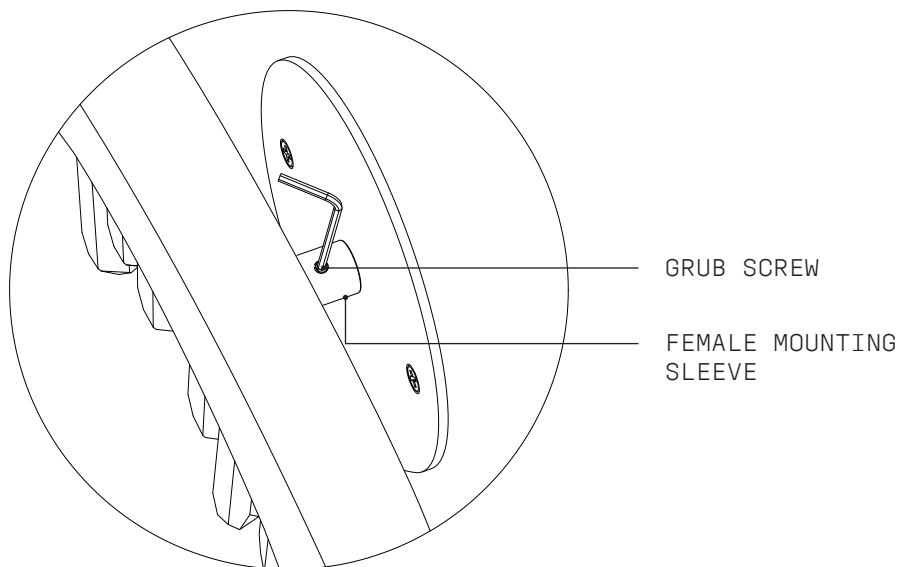

7 Conduct a final visual assessment of the fixture to ensure all parts have been properly fitted and secured. Once satisfied that everything is in working order, remove all remaining protective material which will now complete the installation process.

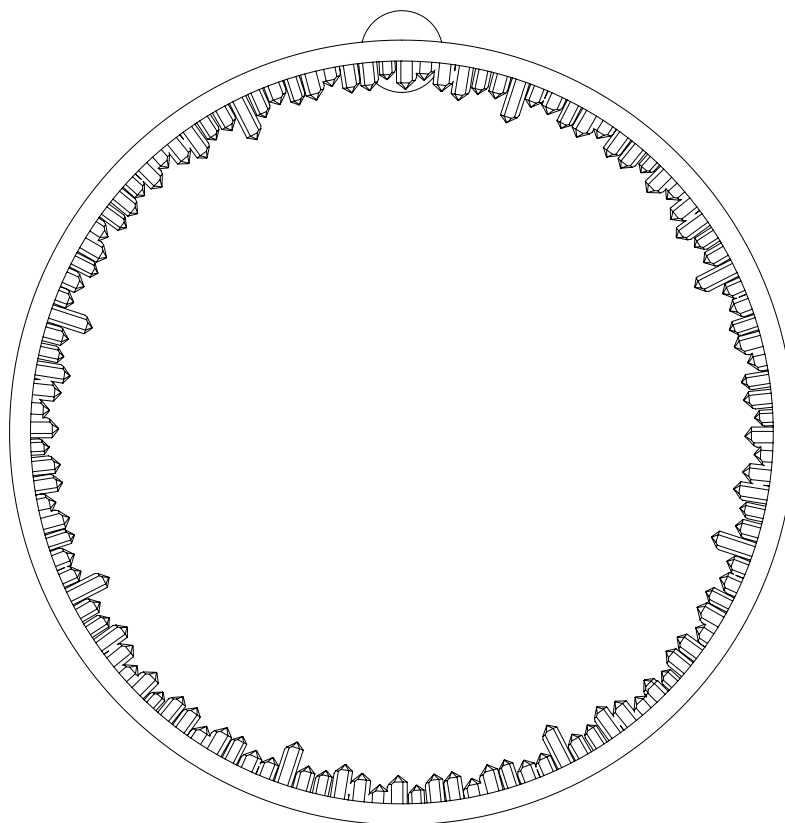

FINISH

CARE INSTRUCTIONS

- The PROMETHEUS IV SCONCE is for indoor use only (unless otherwise specified) and operable to a maximum ambient temperature of 25° Celsius. The lamping of this luminaire, is a non-user replaceable source and must only be replaced by CHRISTOPHER BOOTS, an appointed agent and/or qualified professional of CHRISTOPHER BOOTS. Should your pendant require relamping, please contact sales@christopherboots.com to make necessary arrangements.
- Remove dust by simply running an electrostatic duster or dry cloth every few weeks over all external surfaces.
- Take particular care when dusting internal surfaces as these are extremely delicate. A clean lint-free cloth will be ample.
- Under no circumstances should the fixture be cleaned with any type of liquids/detergents or solvents.
- We recommend using micro fibre cloths.
- If more than dusting is required, please contact us at: sales@christopherboots.com

WARRANTY

1. Christopher Boots offers a 36 month / 3 year warranty from date of receipt of balance payment on all light fittings supplied (not installation) against mechanical defects.
2. Christopher Boots will repair or replace defective components or product within this warranty period.
3. Warranty for components includes:
4. LED lamps and strips: 3 years / 36 months after receipt.
5. LED drivers 60w: 3 years / 36 months after receipt.
6. LED drivers 100w + 150w: 5 years / 60 months after receipt.
7. Incandescent lamps: no warranty – no manufacturer warrants filament lamps.
8. Fixtures are clearly labeled with maximum allowable wattage therefore responsibility of installer / end client to ensure correct lamps & wattages are compliant.
9. Use of higher wattage bulbs than indicated will forfeit warranty.
10. Warranty claims require client to cover shipping enroute back for repair.
11. Any questions? Contact sales@christopherboots.com

CHRISTOPHER BOOTS WILL NOT BE HELD RESPONSIBLE FOR THE FOLLOWING

1. Damage caused by improper cleaning solutions or methods.
2. Damage caused by improper installation or assembly by customer or customer's agent.
3. Damage caused by improper use of light bulbs.
4. Where applicable, installers ensure screwing lamps / glass lamp cover inline with trajectory of product branch + lampholder upon lamp replacement.
5. Where applicable, a screwing motion of slightest angle may cause cross-threading & breakage not covered under warranty.
6. Damage caused by exposure to weather or improper environment – client to check IP rating prior to purchase.
7. Changes in appearance of hand applied finishes or unlacquered finishes.
8. Please note that finishes are designed to age in appearance.
9. Any costs of installation, removal, or re-installation.
10. Restoration, repair work & any parts purchased separately from supplied light fixtures.
11. Damage caused during shipping. All items are packed specifically for global transport.

DAMAGES

1. Damages must be documented and reported within 7 business days of receipt.
2. If external flexible cable of this luminaire is damaged, it shall be exclusively replaced by the manufacturer or your service agent in order to avoid hazard.
3. Photo evidence will be required upon reporting of damage claim.
4. Christopher Boots is not responsible for repair or replacement of damages reported after this time.
5. If damage has occurred in shipping, all packaging must be retained by receiver. Failure to do so may invalidate any claim.

RETURNS

1. Because of the hand-made nature of our product, we unable to offer returns.