

# OKHA

# ZEPPELIN MODULE A Sofas

DESIGNED BY OKHA

twentieth

sales@twentieth.net

323.904.1200

www.twentieth.net

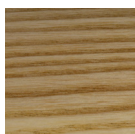
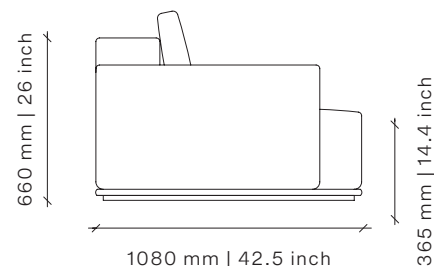
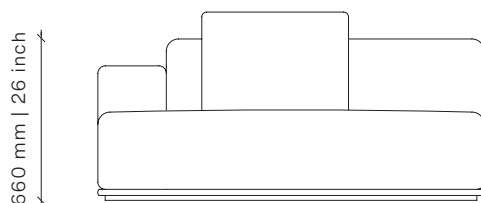
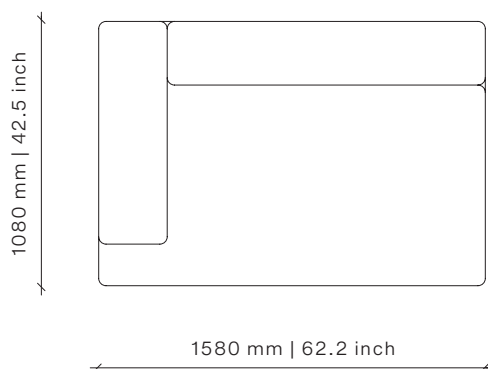

Natural Ash



Chalked Ash

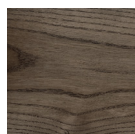

Dark Java Ash

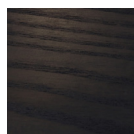

Carbon Stained  
Ash

**Plinth** Ash

**Upholstery** Fabric

#### Dimensions (mm)

1580W x 1080D x 660H

Seat Height: 365 mm

#### Dimensions (inches)

62.2W X 42.5D X 26H

Seat Height: 14.4 in

**COM** 10m / 10.9yd

**COL** 16.8m<sup>2</sup> / 180sq ft

Different textures, grains, colouration and densities are all natural characteristics of timbers. We find these variances an inherent and valuable part of the natural beauty of wood, no two pieces are the same making each OKHA design a unique, characterful piece and each product will be different from the next. Timber movement will also occur as this is a natural product.

STONE: Marble is a beautiful natural material with inherent imperfections in its structure, veining and coloration. As such, some slabs may be reinforced with meshing on the underside and may have colour matched resin fills in minor cracks and surface blemishes. Please note that this is standard practice.

METAL: All metals will go through a process of natural aging and oxidization due to environmental conditions. The result of this aging process will bring about colour change, to slow and reduce this natural process, appropriate cleaning and maintenance products can be used.

# OKHA

twentieth

sales@twentieth.net

323.904.1200

www.twentieth.net

# ZEPPELIN MODULE B Sofas

DESIGNED BY OKHA

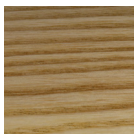
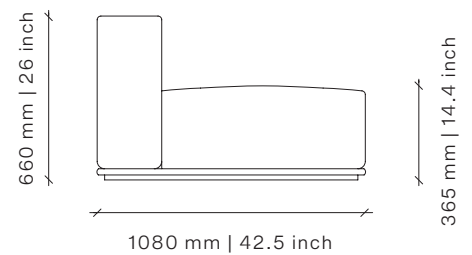
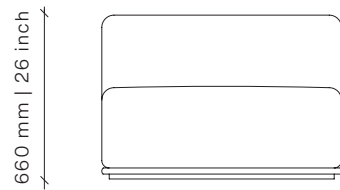
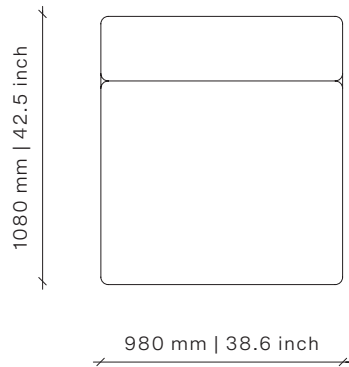

Natural Ash



Chalked Ash

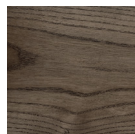

Dark Java Ash

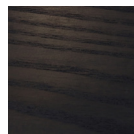

Carbon Stained  
Ash

**Plinth** Ash

**Upholstery** Fabric

### Dimensions (mm)

980W x 1080D x 660H

Seat Height: 365 mm

### Dimensions (inches)

38.6W X 42.5D X 26H

Seat Height: 14.4 in

**COM** 8m / 8.7yd

**COL** 13.5m<sup>2</sup> / 145.31sq ft

Different textures, grains, colouration and densities are all natural characteristics of timbers. We find these variances an inherent and valuable part of the natural beauty of wood, no two pieces are the same making each OKHA design a unique, characterful piece and each product will be different from the next. Timber movement will also occur as this is a natural product.

STONE: Marble is a beautiful natural material with inherent imperfections in its structure, veining and coloration. As such, some slabs may be reinforced with meshing on the underside and may have colour matched resin fills in minor cracks and surface blemishes. Please note that this is standard practice.

METAL: All metals will go through a process of natural aging and oxidization due to environmental conditions. The result of this aging process will bring about colour change, to slow and reduce this natural process, appropriate cleaning and maintenance products can be used.

# OKHA

# ZEPPELIN MODULE C Sofas

DESIGNED BY OKHA

twentieth

sales@twentieth.net

323.904.1200

www.twentieth.net

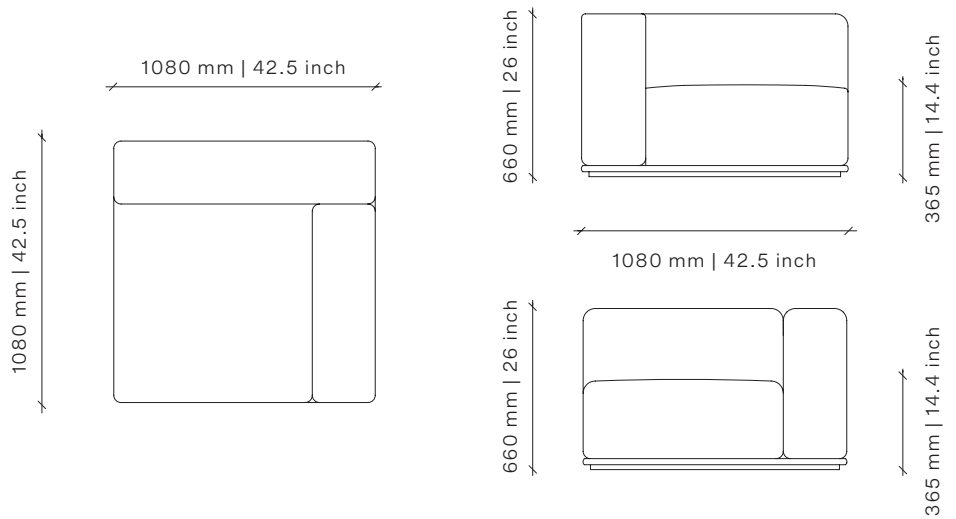

Natural Ash



Chalked Ash

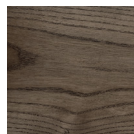

Dark Java Ash

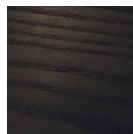

Carbon Stained  
Ash

**Plinth** Ash

**Upholstery** Fabric

#### Dimensions (mm)

1080W x 1080D x 660H

Seat Height: 365 mm

#### Dimensions (inches)

42.5W X 42.5D X 26H

Seat Height: 14.4 in

**COM** 7m / 7.65yd

**COL** 11.8m<sup>2</sup> / 127sq ft

Different textures, grains, colouration and densities are all natural characteristics of timbers. We find these variances an inherent and valuable part of the natural beauty of wood, no two pieces are the same making each OKHA design a unique, characterful piece and each product will be different from the next. Timber movement will also occur as this is a natural product.

STONE: Marble is a beautiful natural material with inherent imperfections in its structure, veining and coloration. As such, some slabs may be reinforced with meshing on the underside and may have colour matched resin fills in minor cracks and surface blemishes. Please note that this is standard practice.

METAL: All metals will go through a process of natural aging and oxidation due to environmental conditions. The result of this aging process will bring about colour change, to slow and reduce this natural process, appropriate cleaning and maintenance products can be used.

twentieth

sales@twentieth.net

323.904.1200

www.twentieth.net

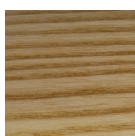
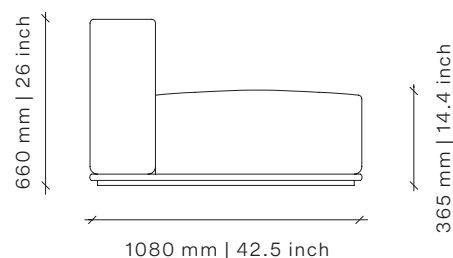
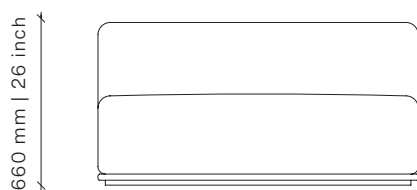
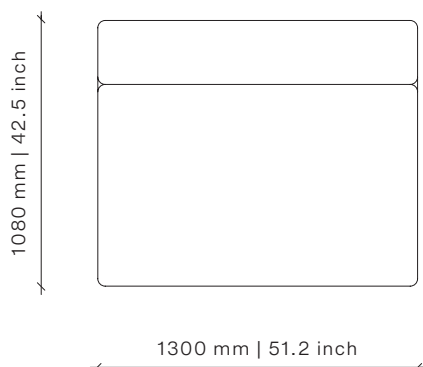

Natural Ash



Chalked Ash

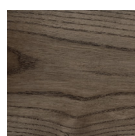

Dark Java Ash

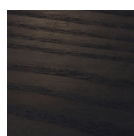

Carbon Stained  
Ash

**Plinth** Ash

**Upholstery** Fabric

**Dimensions (mm)**

1300W x 1080D x 660H

Seat Height: 365 mm

**Dimensions (inches)**

51.2W X 42.5D X 26H

Seat Height: 14.4 in

**COM** 6m / 6.5yd

**COL** 10m<sup>2</sup> / 107.6sq ft

Different textures, grains, colouration and densities are all natural characteristics of timbers. We find these variances an inherent and valuable part of the natural beauty of wood, no two pieces are the same making each OKHA design a unique, characterful piece and each product will be different from the next. Timber movement will also occur as this is a natural product.

STONE: Marble is a beautiful natural material with inherent imperfections in its structure, veining and coloration. As such, some slabs may be reinforced with meshing on the underside and may have colour matched resin fills in minor cracks and surface blemishes. Please note that this is standard practice.

METAL: All metals will go through a process of natural aging and oxidization due to environmental conditions. The result of this aging process will bring about colour change, to slow and reduce this natural process, appropriate cleaning and maintenance products can be used.

# OKHA

twentieth

sales@twentieth.net

323.904.1200

www.twentieth.net

## ZEPPELIN MODULE E Sofas

DESIGNED BY OKHA

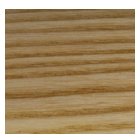
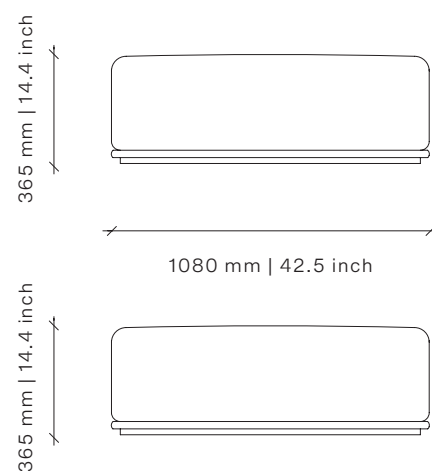
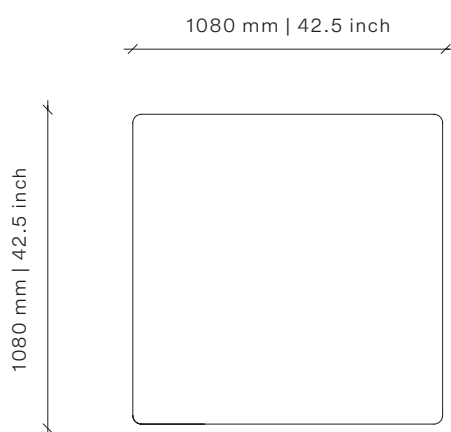

Natural Ash

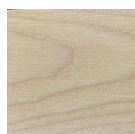

Chalked Ash

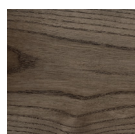

Dark Java Ash

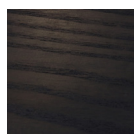

Carbon Stained  
Ash

**Plinth** Ash

**Upholstery** Fabric

### Dimensions (mm)

1080W x 1080D x 365H

Seat Height: 365 mm

### Dimensions (inches)

42.5W X 42.5D X 14.4H

Seat Height: 14.4 in

**COM** 3m / 3.2yd

**COL** 5.5m<sup>2</sup> / 59.2sq ft

Different textures, grains, colouration and densities are all natural characteristics of timbers. We find these variances an inherent and valuable part of the natural beauty of wood, no two pieces are the same making each OKHA design a unique, characterful piece and each product will be different from the next. Timber movement will also occur as this is a natural product.

STONE: Marble is a beautiful natural material with inherent imperfections in its structure, veining and coloration. As such, some slabs may be reinforced with meshing on the underside and may have colour matched resin fills in minor cracks and surface blemishes. Please note that this is standard practice.

METAL: All metals will go through a process of natural aging and oxidation due to environmental conditions. The result of this aging process will bring about colour change, to slow and reduce this natural process, appropriate cleaning and maintenance products can be used.