

LITTLE DIAMOND

LIT-DIA

FRONT

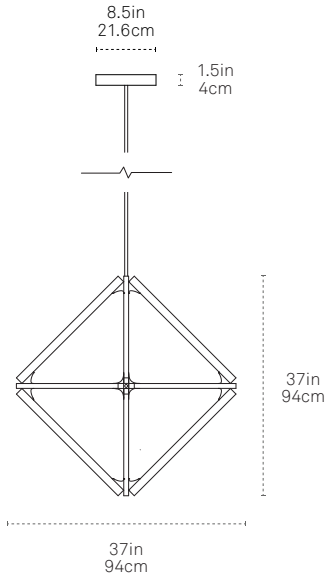

SIDE

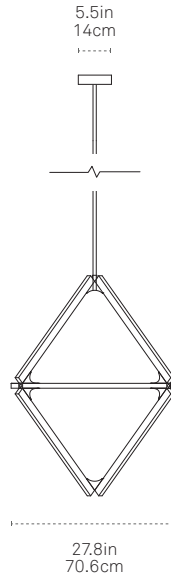

PLAN

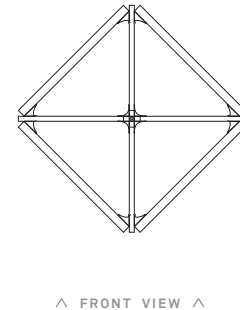

□ Bulb Profile
0.81in x 1.3in
2.1cm x 3.3cm

SPECIFY PRODUCT OPTIONS:

MODEL

LIT-DIA

WOOD	METAL	COLOR TEMP	DRIVER	OUTPUT	STEM	CEILING
<input type="checkbox"/>	<input type="checkbox"/>	<input type="checkbox"/>	<input type="checkbox"/>	<input type="checkbox"/>	<input type="checkbox"/>	<input type="checkbox"/>

DESIGN

© 2017

MATERIALS

LED, Sustainably Sourced or Reclaimed Wood, Brass

FEATURES

Fully Dimmable
Ships assembled
60-inch drop stem included

CERTIFICATIONS



ORIGIN OF MANUFACTURE

New York City, USA

FIXTURE WEIGHT

14.2 lbs / 6.4 kg

SHIPPING DIMENSIONS

Ships assembled in a wooden crate and a corrugated cardboard box.
34 in x 31 in x 26 in, 60 in x 7 in x 7 in
85 x 77 x 65 cm, 152 x 18 x 18 cm
110 lbs / 50 kg

LIGHT SPECIFICATION

Standard Brightness LEDs :
1,276 Lumens / 94 CRI (3000K) /
41W Power draw

WOOD*

Maple	<input type="checkbox"/>
American Walnut	<input type="checkbox"/>
Ebonized Oak	<input type="checkbox"/>
Heart Pine (Reclaimed)**	<input type="checkbox"/>
Water Tower Redwood (Reclaimed)**	<input type="checkbox"/>

* Custom options available upon approval.

** Our reclaimed woods exhibit variations in tone and grain.

METAL*

Brushed Nickel	<input type="checkbox"/>
Polished Nickel	<input type="checkbox"/>
Brushed Brass	<input type="checkbox"/>
Polished Brass	<input type="checkbox"/>
Blackened	<input type="checkbox"/>

* Custom options available upon approval.

COLOR TEMP

2400K	<input type="checkbox"/>
2700K	<input type="checkbox"/>
3000K (Standard)	<input type="checkbox"/>
4000K	<input type="checkbox"/>

DRIVER & DIMMING OPTIONS

120V (2-wire+G Forward phase 1% dimming)	<input type="checkbox"/>
120V-277V (3-wire+G 1% dimming)	<input type="checkbox"/>
120V-277V (Universal dimming including 0-10V)**	<input type="checkbox"/>

** Recommended for European orders

LIGHT OUTPUT

Standard Brightness - 12V (Dimmable)	<input type="checkbox"/>
--------------------------------------	--------------------------

STEM LENGTH*

60" length of 3/8" rigid steel stem	<input type="checkbox"/>
120" length of 3/8" rigid steel stem	<input type="checkbox"/>
180" length of 3/8" rigid steel stem	<input type="checkbox"/>

* Drop stem can be cut to length on site. 60" is included; contact a sales representative for 120" and 180" pricing.

CEILING

Flat Ceiling	<input type="checkbox"/>
Sloped Ceiling**	<input type="checkbox"/>

** Canopy Dimension : 12"(L) x 5.5"(W) x 1.5"(H)

DIMMING COMPATIBILITY

Lutron Hi-lume 1% 2-Wire LTE Standard & High Brightness

1 2 0

120V driver (2-wire+G Forward phase 1% dimming)

Full manufacturer's specification sheets can be found at stickbulb.com/drivers/120

Compatible Controls: Lutron Neutral-wire Dimmers

For assistance selecting controls contact Lutron at 1.877.346.5338 or LEDs@lutron.com

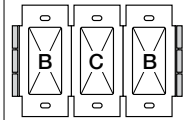
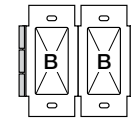
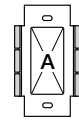

Product	Part Number	Low-End Setting/Load-Type Setting ¹	Drivers per Control		
			A: Not Ganged	B: End of Gang	C: Middle of Gang
RadioRA 2 adaptive dimmer	RRD-6NA-	Hi-lume 1% 2-Wire LTE LED ²	1-10, 400 W max	1-10, 400 W max	1-10, 400 W max
RA2 Select/RadioRA 2 600 W dimmer	RRD-6ND	Hi-lume 1% 2-Wire LTE LED ²	1-8, 350 W max	1-8, 350 W max	1-8, 350 W max
RadioRA 2 1000 W dimmer	RRD-10ND-	Set Device type to "INC/MLV Neutral Dimmer"; Set High-End Trim to 99%; Set Low-End Trim to 35%	1-13	1-13	1-13
RadioRA 2 Architectural RF GRAFIK T phase selectable dimmer	RRT-G5NEW-	Trim low-end per APM App Note (Lutron P/N 048534)	1-10, 400 W max	1-10, 400 W max	1-10, 400 W max
RadioRA 2 Architectural RF GRAFIK T dimmer	RRT-G25LW-	Trim low-end per APM App Note (Lutron P/N 048534)	1-10, 400 W max	1-10, 400 W max	1-10, 400 W max
RadioRA 2 C•L hybrid seeTouch keypad	RRD-HN	Hi-lume 1% 2-Wire LTE LED ²	1-10, 200 W max	1-10, 200 W max	1-10, 200 W max
RadioRA 2 GRAFIK T C•L hybrid keypad	RRT-GH	Hi-lume 1% 2-Wire LTE LED ²	1-10, 400 W max	1-10, 400 W max	1-10, 400 W max
HomeWorks QS adaptive dimmer	HQRD-6NA-	Hi-lume 1% 2-Wire LTE LED ²	1-10, 400 W max	1-10, 400 W max	1-10, 400 W max
HomeWorks QS 600 W dimmer	HQRD-6ND-	Hi-lume 1% 2-Wire LTE LED ²	1-8, 350 W max	1-8, 350 W max	1-8, 350 W max
HomeWorks QS 1000 W dimmer	HQRD-10ND-	Hi-lume 1% 2-Wire LTE LED ²	1-13	1-13	1-13
Maestro Wireless 600 W dimmer	MRF2-6ND-120-	Trim low-end per APM App Note (Lutron P/N 048370)	1-8, 350 W max	1-8, 350 W max	1-8, 350 W max
Vive Maestro Wireless 600 W dimmer	MRF2S-6ND-120-	Trim low-end per APM App Note (Lutron P/N 048370)	1-8, 350 W max	1-8, 350 W max	1-8, 350 W max
HomeWorks QS GRAFIK T hybrid keypad	HQRT-GH	Hi-lume 1% 2-Wire LTE LED ²	1-10, 400 W max	1-10, 400 W max	1-10, 400 W max
HomeWorks QS Architectural GRAFIK T dimmer	HQRT-G25LW-	Hi-lume 1% 2-Wire LTE LED ²	1-10, 400 W max	1-10, 400 W max	1-10, 400 W max
HomeWorks QS Architectural GRAFIK T phase selectable dimmer	HQRT-G5NEW-	Hi-lume 1% 2-Wire LTE LED ²	1-10, 400 W max	1-10, 400 W max	1-10, 400 W max
HomeWorks QS designer C•L hybrid seeTouch keypad	HQRD-HN	Hi-lume 1% 2-Wire LTE LED ²	1-10, 200 W max	1-10, 200 W max	1-10, 200 W max
GRAFIK T C•L 250 W dimmer	GT-250M-, GTJ-250M-	Set low-end trim per dimmer installation instructions	1-10, 400 W max	1-10, 400 W max	1-10, 400 W max
Caséta Wireless Pro 1000 W dimmer	PD-10NXD-	Trim low-end per instructions at casetawireless.com/lowend	1-13	1-13	1-13
Caséta Wireless phase selectable dimmer	PD-5NE-	Trim low-end per instructions at casetawireless.com/lowend	1-20, 400 W max	1-20, 400 W max	1-20, 400 W max

¹ Setting the low-end trim and load type is necessary to ensure optimal performance and 1% dimming capability.

² Also listed as "LED Lutron A-Series 2-Wire" or "Hi-Lume A-Series LTE LED Driver 2-Wire" in previous software releases.

(TO BE CONTINUED ON NEXT PAGE)

DIMMING COMPATIBILITY

(CONTINUED from

1	2	0
---	---	---

)

Compatible Controls: Lutron Non-Neutral Dimmers

For assistance selecting controls contact Lutron at 1.877.346.5338 or LEDs@lutron.com

Product	Part Number	Dimers per Control	Low-End Setting/Load-Type Setting ¹		
Ariadni C•L 250 W dimmer	AYCL-253P-	Set low-end trim dial to 1 o'clock. Adjust slightly if needed.	1-8, 350 W max	1-8, 350 W max	1-8, 350 W max
Ariadni C•L 150 W dimmer	TGCL-153P-, AYCL-153P-	Set low-end trim dial to 1 o'clock. Adjust slightly if needed.	1-6, 250 W max	1-6, 250 W max	1-6, 250 W max
Diva C•L 250 W dimmer	DVCL-253P-, DVSCCL-253P-	Set low-end trim dial to 10 o'clock. Adjust slightly if needed.	1-8, 350 W max	1-8, 350 W max	1-8, 350 W max
Diva C•L 150 W dimmer	DVCL-153P-, DVSCCL-153P-	Set low-end trim dial to 10 o'clock. Adjust slightly if needed.	1-6, 250 W max	1-6, 250 W max	1-6, 250 W max
Nova Tr C•L 250 W dimmer	NTCL-250-	Set low-end trim dial to 10 o'clock. Adjust slightly if needed.	1-10, 400 W max	1-10, 400 W max	1-10, 400 W max
Lumea C•L 150 W dimmer	LECL-153P-	Set low-end trim dial to 10 o'clock. Adjust slightly if needed.	1-6, 250 W max	1-6, 250 W max	1-6, 250 W max
Sylark C•L 150 W dimmer	SCL-153P-	Set low-end trim dial to 10 o'clock. Adjust slightly if needed.	1-6, 250 W max	1-6, 250 W max	1-6, 250 W max
Contour C•L 150 W dimmer	CTCL-153P-	Set low-end trim dial to 10 o'clock. Adjust slightly if needed.	1-6, 250 W max	1-6, 250 W max	1-6, 250 W max
myRoom DIN power module	MQSE-4A1-D	1-6 (per output); 1 A maximum driver input current	Hi-lume 1% 2-Wire LTE LED ²		
HomeWorks QS DIN power module	LQSE-4A1-D	1-6 (per output); 1 A maximum driver input current	Hi-lume 1% 2-Wire LTE LED ²		
HomeWorks QS Phase Adaptive DIN power module	LQSE-4A-120-D	1-6 (per output); 2 A maximum driver input current	Hi-lume 1% 2-Wire LTE LED ²		
HomeWorks QS wallbox power module	HQRJ-WPM-6D-120	2-10 (per output); 26 total per module	Hi-lume 1% 2-Wire LTE LED ²		
HomeWorks wallbox power module	HWI-WPM-6D-120	2-10 (per output); 26 total per module	Set load type to "GRX-FDBI or GRX-TVI"		
GRAFIK Eye QS control unit	QSGR-, QSGRJ-	2-10 (per output); 26 total per unit	Set load type to "Fluorescent Module"		
GRAFIK Eye 3000 control unit	GRX-3100-, GRX-3500-	2-10 (per output); 26 total per module	Set load type to "GRX-FDBI" or "GRX-TVI"		
RPM-4U module (LCP, HomeWorks QS, GRAFIK Systems, Quantum)	HW-RPM-4U-120, LP-RPM-4U-120	2-26 (per output); 26 total per module	Hi-lume 1% 2-Wire LTE LED ² Set load type to "2-1"		
RPM-4A module (LCP, HomeWorks QS, GRAFIK Systems, Quantum)	HW-RPM-4A-120, LP-RPM-4A-120	1-13 (per output); 26 total per module	Hi-lume 1% 2-Wire LTE LED ² Set load type to "2-1"		
GP dimming panels	Various	1-26	Set load type to "2-1"		

¹ Setting the low-end trim and load type is necessary to ensure optimal performance and 1% dimming capability.

² Also listed as "LED Lutron A-Series 2-Wire" or "Hi-lume A-Series LTE LED Driver 2-Wire" in previous software releases.

DIMMING COMPATIBILITY

Lutron Hi-Lume 1% EcoSystem/3-Wire L3D Standard & High Brightness

2	7	7
---	---	---

120-277V driver (3-wire+G 1% dimming)

Full manufacturer's specification sheets can be found at stickbulb.com/drivers/277

Compatible Controls

For assistance selecting controls, contact Lutron at 1.877.346.5338 or LEDs@lutron.com

Product	Part Number		Drivers per Control				Measured Light Output Range
			40 W Driver		50 W Driver		
	120 V ~	277 V ~	120 V ~	277 V ~	120 V ~	277 V ~	
3-wire Controls:							
Nova T	NTF-10-	NTF-10-277-	1-41	1-44	1-31	1-36	100%-1%
	NTF-103P-	NTF-103P-277-	1-20	1-33	1-15	1-27	100%-1%
Nova	NF-10-	NF-10-277-	1-41	1-44	1-31	1-36	100%-1%
	NF-103P-	NF-103P-277-	1-20	1-33	1-15	1-27	100%-1%
Skylark	SF-10P-	SF-12P-277-	1-20	1-33	1-15	1-27	100%-1%
	SF-103P-	SF-12P-277-3	1-20	1-33	1-15	1-27	100%-1%
Diva	DVF-103P-	DVF-103P-277-	1-20	1-33	1-15	1-27	100%-1%
	DVSCF-103P-	DVSCF-103P-277-	1-20	1-33	1-15	1-27	100%-1%
Ariadni	AYF-103P-	AYF-103P-277-	1-20	1-44	1-15	1-27	100%-1%
Maestro	MAF-6AM-	MAF-6AM-277-	1-15	1-20	1-11	1-20	100%-1%
	MSCF-6AM-	MSCF-6AM-277-	1-15	1-20	1-11	1-20	100%-1%
Maestro Wireless	MRF2-F6AN-DV-		1-15	1-33	1-11	1-27	100%-1%
RadioRA 2	RRD-F6AN-DV-		1-15	1-33	1-11	1-27	100%-1%
HomeWorks QS	HQRD-F6AN-DV		1-15	1-33	1-11	1-27	100%-1%
Interfaces ¹	PHPM-3F-120	-	1-41	-	1-31	-	100%-1%
	PHPM-3F-DV		1-41	1-88	1-31	1-72	100%-1%
GP Dimming Panels	Various		1-41	1-88	1-31	1-72	100%-1%
EcoSystem Controls:							
PowPak dimming module with EcoSystem	RMJ-ECO32-DV-B		32 per EcoSystem link				100%-1%
	FCJ-ECO		3 per EcoSystem link ²				100%-1%
Energi Savr Node with EcoSystem	QSN-1ECO-S, QSN-2ECO-S		64 per EcoSystem link				100%-1%
GRAFIK Eye QS with EcoSystem	QSGRJ-_E, QSGR-_E	-	64 per EcoSystem link				100%-1%
Quantum	Various		64 per EcoSystem link				100%-1%

¹ For use with 3-wire controls or Commercial Systems, RadioRA 2 Systems or Home Systems applications.

² Up to 3 drivers controlled as a single zone (broadcast EcoSystem).

DIMMING COMPATIBILITY

L.T.F.® 0-10V Drivers

0	1	0
---	---	---

120V-277V driver (Universal dimming including 0–10V)

Full manufacturer's specification sheets can be found at stickbulb.com/drivers/010

Low-Voltage Compatible Dimmer brands: Crestron, Lutron, Leviton

For assistance selecting controls, contact LTF at +1 (847) 498-5832 or LTFsales@LTFtechnology.com

Brand	Part number
Crestron	CLS-C6
Crestron	CLS-C6M
Crestron	CLS-C6EX
Crestron	CLS-C6MEX
Crestron	CLS-EXP-DIM
Crestron	CLS-EXP-DIMU
Crestron	CLX-2DIM8
Crestron	DIN-1DIM4
Crestron	DIN-1DIMU4
Crestron	CLW-DIMEX-E
Crestron	CLW-DIMEX-P
Crestron	CLW-DIMSWEX-E
Crestron	CLW-DIMSWEX-P
Crestron	GLX-DIM6
Crestron	GLXX-2DIM8
Crestron	P-DIMEX
Crestron	CLW-DELVEX-E
Crestron	CLW-DELVEX-P

Brand	Part number
Lutron	DVCL-153P
Lutron	DVELV-303P
Lutron	HQRD-6A
Lutron	HQRD-6NA-
Lutron	NTELV-300-
Lutron	NTELV-600-
Lutron	NVELV-600-
Lutron	VTELV-600M
Lutron	MAELV-600-
Lutron	MSCELV-600M
Lutron	MIRELV-600-
Lutron	MRF2-6ELV-120-
Lutron	SELV-300P
Lutron	CTELV-303P
Lutron	SELV-600-

Brand	Part number
Leviton	Model 6615
Leviton	Model 6672
Leviton	Model 6674
Leviton	Model IPL06
Leviton	Model IPE04
Leviton	Model IPI06
Leviton	Model VP106
Leviton	Model VPE04
Leviton	Model VPM06
Leviton	Model VRE04
Leviton	Model VRM10

CLEANING INSTRUCTIONS

All of our wood and metal products should be dusted by hand with a dry Swiffer pad (or equivalent) on a regular schedule to maintain surface integrity. **It is imperative that none of our products come into contact with bleach, vinegar, lemon juice or any household product which may contain these or other solvents.**

If any part of one of our fixtures becomes soiled with dried residue or grime, wipe the affected area with a soft cloth dampened very lightly with warm water and immediately wipe dry with another soft cloth. If this does not complete the task, wipe with a cloth soaked in diluted mild liquid dish soap and again immediately dry.

Fingerprints on our Nickel-plated, Brass-plated, and Blackened metal hardware can be removed with a clean, dry, soft cloth. We recommend an ultra-fine, textureless microfiber cleaning cloth (as one uses to clean glass). Stubborn stains **on Nickel only** may be removed with a light application of Windex.

All of our Brass hardware is treated with a protective coating to prevent tarnish. It should need no more than a wipe with a clean, dry, soft cloth to remove fingerprints and dust.

Brushed metal surfaces should be buffed in the direction of the grain.

For scratches in wood we highly recommend Claphams beeswax, which is non-toxic and can be applied by hand. Rub a small amount into the scratch area and buff with a dry cloth.

MIDDLE DIAMOND

MID-DIA

FRONT

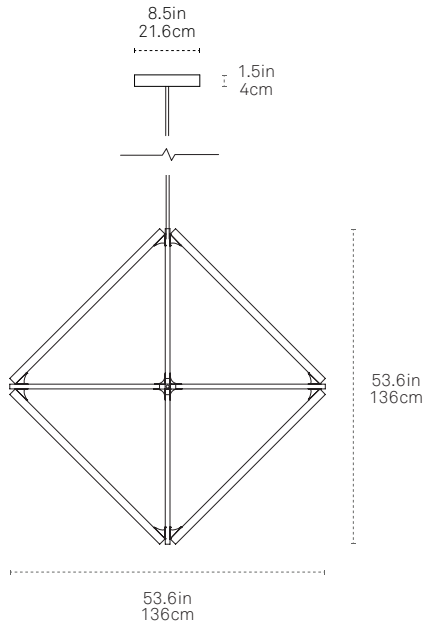

SIDE

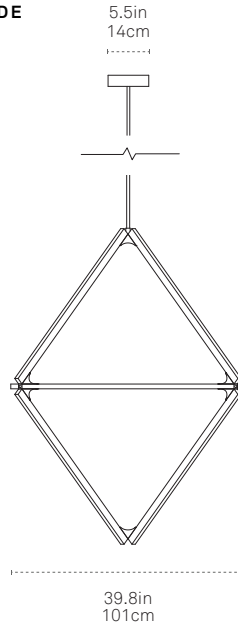

PLAN

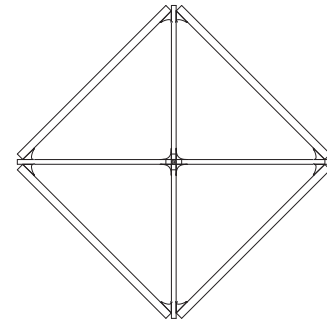

□ Bulb Profile
0.81in x 1.3in
2.1cm x 3.3cm

^ FRONT VIEW ^

SPECIFY PRODUCT OPTIONS:

MODEL

MID-DIA

WOOD

METAL

COLOR TEMP

DRIVER

OUTPUT

STEM

CEILING

DESIGN

© 2017

MATERIALS

LED, Sustainably Sourced or Reclaimed Wood, Brass

FEATURES

Fully Dimmable
Ships assembled
60-inch drop stem included

CERTIFICATIONS



ORIGIN OF MANUFACTURE

New York City, USA

FIXTURE WEIGHT

16.6 lbs / 7.5 kg

SHIPPING DIMENSIONS

Ships assembled in a wooden crate.
47 in x 44 in x 35.5 in
119 cm x 112 cm x 90 cm
150 lbs / 68 kg

LIGHT SPECIFICATION

Standard Brightness LEDs :
2,126 Lumens / 94 CRI (3000K) /
68W Power draw

WOOD*

Maple

M A

American Walnut

W A

Ebonized Oak

E O

Heart Pine (Reclaimed)**

H P

Water Tower Redwood (Reclaimed)**

W T

* Custom options available upon approval.

** Our reclaimed woods exhibit variations in tone and grain.

METAL*

Brushed Nickel

B N

Polished Nickel

P N

Brushed Brass

B B

Polished Brass

P B

Blackened

B L

* Custom options available upon approval.

COLOR TEMP

2400K

2 4 0 0

2700K

2 7 0 0

3000K (Standard)

3 0 0 0

4000K

4 0 0 0

DRIVER & DIMMING OPTIONS

120V (2-wire+G Forward phase 1% dimming)

1 2 0

120V-277V (3-wire+G 1% dimming)

2 7 7

120V-277V (Universal dimming including 0-10V)**

0 1 0

** Recommended for European orders

LIGHT OUTPUT

Standard Brightness - 12V (Dimmable)

S B

STEM LENGTH*

60" length of 3/8" rigid steel stem

0 6 0

120" length of 3/8" rigid steel stem

1 2 0

180" length of 3/8" rigid steel stem

1 8 0

* Drop stem can be cut to length on site. 60" is included; contact a sales representative for 120" and 180" pricing.

CEILING

Flat Ceiling

F

Sloped Ceiling**

S

** Canopy Dimension : 12"(L) x 5.5"(W) x 1.5"(H)

DIMMING COMPATIBILITY

Lutron Hi-lume 1% 2-Wire LTE Standard & High Brightness

1 2 0

120V driver (2-wire+G Forward phase 1% dimming)

Full manufacturer's specification sheets can be found at stickbulb.com/drivers/120

Compatible Controls: Lutron Neutral-wire Dimmers

For assistance selecting controls contact Lutron at 1.877.346.5338 or LEDs@lutron.com

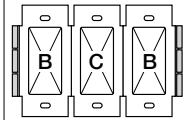
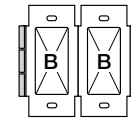
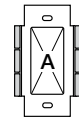

Product	Part Number	Low-End Setting/Load-Type Setting ¹	Drivers per Control		
			A: Not Ganged	B: End of Gang	C: Middle of Gang
RadioRA 2 adaptive dimmer	RRD-6NA-	Hi-lume 1% 2-Wire LTE LED ²	1-10, 400 W max	1-10, 400 W max	1-10, 400 W max
RA2 Select/RadioRA 2 600 W dimmer	RRD-6ND	Hi-lume 1% 2-Wire LTE LED ²	1-8, 350 W max	1-8, 350 W max	1-8, 350 W max
RadioRA 2 1000 W dimmer	RRD-10ND-	Set Device type to "INC/MLV Neutral Dimmer"; Set High-End Trim to 99%; Set Low-End Trim to 35%	1-13	1-13	1-13
RadioRA 2 Architectural RF GRAFIK T phase selectable dimmer	RRT-G5NEW-	Trim low-end per APM App Note (Lutron P/N 048534)	1-10, 400 W max	1-10, 400 W max	1-10, 400 W max
RadioRA 2 Architectural RF GRAFIK T dimmer	RRT-G25LW-	Trim low-end per APM App Note (Lutron P/N 048534)	1-10, 400 W max	1-10, 400 W max	1-10, 400 W max
RadioRA 2 C•L hybrid seeTouch keypad	RRD-HN	Hi-lume 1% 2-Wire LTE LED ²	1-10, 200 W max	1-10, 200 W max	1-10, 200 W max
RadioRA 2 GRAFIK T C•L hybrid keypad	RRT-GH	Hi-lume 1% 2-Wire LTE LED ²	1-10, 400 W max	1-10, 400 W max	1-10, 400 W max
HomeWorks QS adaptive dimmer	HQRD-6NA-	Hi-lume 1% 2-Wire LTE LED ²	1-10, 400 W max	1-10, 400 W max	1-10, 400 W max
HomeWorks QS 600 W dimmer	HQRD-6ND-	Hi-lume 1% 2-Wire LTE LED ²	1-8, 350 W max	1-8, 350 W max	1-8, 350 W max
HomeWorks QS 1000 W dimmer	HQRD-10ND-	Hi-lume 1% 2-Wire LTE LED ²	1-13	1-13	1-13
Maestro Wireless 600 W dimmer	MRF2-6ND-120-	Trim low-end per APM App Note (Lutron P/N 048370)	1-8, 350 W max	1-8, 350 W max	1-8, 350 W max
Vive Maestro Wireless 600 W dimmer	MRF2S-6ND-120-	Trim low-end per APM App Note (Lutron P/N 048370)	1-8, 350 W max	1-8, 350 W max	1-8, 350 W max
HomeWorks QS GRAFIK T hybrid keypad	HQRT-GH	Hi-lume 1% 2-Wire LTE LED ²	1-10, 400 W max	1-10, 400 W max	1-10, 400 W max
HomeWorks QS Architectural GRAFIK T dimmer	HQRT-G25LW-	Hi-lume 1% 2-Wire LTE LED ²	1-10, 400 W max	1-10, 400 W max	1-10, 400 W max
HomeWorks QS Architectural GRAFIK T phase selectable dimmer	HQRT-G5NEW-	Hi-lume 1% 2-Wire LTE LED ²	1-10, 400 W max	1-10, 400 W max	1-10, 400 W max
HomeWorks QS designer C•L hybrid seeTouch keypad	HQRD-HN	Hi-lume 1% 2-Wire LTE LED ²	1-10, 200 W max	1-10, 200 W max	1-10, 200 W max
GRAFIK T C•L 250 W dimmer	GT-250M-, GTJ-250M-	Set low-end trim per dimmer installation instructions	1-10, 400 W max	1-10, 400 W max	1-10, 400 W max
Caséta Wireless Pro 1000 W dimmer	PD-10NXD-	Trim low-end per instructions at casetawireless.com/lowend	1-13	1-13	1-13
Caséta Wireless phase selectable dimmer	PD-5NE-	Trim low-end per instructions at casetawireless.com/lowend	1-20, 400 W max	1-20, 400 W max	1-20, 400 W max

¹ Setting the low-end trim and load type is necessary to ensure optimal performance and 1% dimming capability.

² Also listed as "LED Lutron A-Series 2-Wire" or "Hi-Lume A-Series LTE LED Driver 2-Wire" in previous software releases.

(TO BE CONTINUED ON NEXT PAGE)

DIMMING COMPATIBILITY

(CONTINUED from

1	2	0
---	---	---

)

Compatible Controls: Lutron Non-Neutral Dimmers

For assistance selecting controls contact Lutron at 1.877.346.5338 or LEDs@lutron.com

Product	Part Number	Dimers per Control	Low-End Setting/Load-Type Setting ¹		
Ariadni C•L 250 W dimmer	AYCL-253P-	Set low-end trim dial to 1 o'clock. Adjust slightly if needed.	1-8, 350 W max	1-8, 350 W max	1-8, 350 W max
Ariadni C•L 150 W dimmer	TGCL-153P-, AYCL-153P-	Set low-end trim dial to 1 o'clock. Adjust slightly if needed.	1-6, 250 W max	1-6, 250 W max	1-6, 250 W max
Diva C•L 250 W dimmer	DVCL-253P-, DVSCCL-253P-	Set low-end trim dial to 10 o'clock. Adjust slightly if needed.	1-8, 350 W max	1-8, 350 W max	1-8, 350 W max
Diva C•L 150 W dimmer	DVCL-153P-, DVSCCL-153P-	Set low-end trim dial to 10 o'clock. Adjust slightly if needed.	1-6, 250 W max	1-6, 250 W max	1-6, 250 W max
Nova Tr C•L 250 W dimmer	NTCL-250-	Set low-end trim dial to 10 o'clock. Adjust slightly if needed.	1-10, 400 W max	1-10, 400 W max	1-10, 400 W max
Lumea C•L 150 W dimmer	LECL-153P-	Set low-end trim dial to 10 o'clock. Adjust slightly if needed.	1-6, 250 W max	1-6, 250 W max	1-6, 250 W max
Sylark C•L 150 W dimmer	SCL-153P-	Set low-end trim dial to 10 o'clock. Adjust slightly if needed.	1-6, 250 W max	1-6, 250 W max	1-6, 250 W max
Contour C•L 150 W dimmer	CTCL-153P-	Set low-end trim dial to 10 o'clock. Adjust slightly if needed.	1-6, 250 W max	1-6, 250 W max	1-6, 250 W max
myRoom DIN power module	MQSE-4A1-D	1-6 (per output); 1 A maximum driver input current	Hi-lume 1% 2-Wire LTE LED ²		
HomeWorks QS DIN power module	LQSE-4A1-D	1-6 (per output); 1 A maximum driver input current	Hi-lume 1% 2-Wire LTE LED ²		
HomeWorks QS Phase Adaptive DIN power module	LQSE-4A-120-D	1-6 (per output); 2 A maximum driver input current	Hi-lume 1% 2-Wire LTE LED ²		
HomeWorks QS wallbox power module	HQRJ-WPM-6D-120	2-10 (per output); 26 total per module	Hi-lume 1% 2-Wire LTE LED ²		
HomeWorks wallbox power module	HWI-WPM-6D-120	2-10 (per output); 26 total per module	Set load type to "GRX-FDBI or GRX-TVI"		
GRAFIK Eye QS control unit	QSGR-, QSGRJ-	2-10 (per output); 26 total per unit	Set load type to "Fluorescent Module"		
GRAFIK Eye 3000 control unit	GRX-3100-, GRX-3500-	2-10 (per output); 26 total per module	Set load type to "GRX-FDBI" or "GRX-TVI"		
RPM-4U module (LCP, HomeWorks QS, GRAFIK Systems, Quantum)	HW-RPM-4U-120, LP-RPM-4U-120	2-26 (per output); 26 total per module	Hi-lume 1% 2-Wire LTE LED ² Set load type to "2-1"		
RPM-4A module (LCP, HomeWorks QS, GRAFIK Systems, Quantum)	HW-RPM-4A-120, LP-RPM-4A-120	1-13 (per output); 26 total per module	Hi-lume 1% 2-Wire LTE LED ² Set load type to "2-1"		
GP dimming panels	Various	1-26	Set load type to "2-1"		

¹ Setting the low-end trim and load type is necessary to ensure optimal performance and 1% dimming capability.

² Also listed as "LED Lutron A-Series 2-Wire" or "Hi-lume A-Series LTE LED Driver 2-Wire" in previous software releases.

DIMMING COMPATIBILITY

Lutron Hi-Lume 1% EcoSystem/3-Wire L3D Standard & High Brightness

2	7	7
---	---	---

120-277V driver (3-wire+G 1% dimming)

Full manufacturer's specification sheets can be found at stickbulb.com/drivers/277

Compatible Controls

For assistance selecting controls, contact Lutron at 1.877.346.5338 or LEDs@lutron.com

Product	Part Number		Drivers per Control				Measured Light Output Range
			40 W Driver		50 W Driver		
	120 V ~	277 V ~	120 V ~	277 V ~	120 V ~	277 V ~	
3-wire Controls:							
Nova T	NTF-10-	NTF-10-277-	1-41	1-44	1-31	1-36	100%-1%
	NTF-103P-	NTF-103P-277-	1-20	1-33	1-15	1-27	100%-1%
Nova	NF-10-	NF-10-277-	1-41	1-44	1-31	1-36	100%-1%
	NF-103P-	NF-103P-277-	1-20	1-33	1-15	1-27	100%-1%
Skylark	SF-10P-	SF-12P-277-	1-20	1-33	1-15	1-27	100%-1%
	SF-103P-	SF-12P-277-3	1-20	1-33	1-15	1-27	100%-1%
Diva	DVF-103P-	DVF-103P-277-	1-20	1-33	1-15	1-27	100%-1%
	DVSCF-103P-	DVSCF-103P-277-	1-20	1-33	1-15	1-27	100%-1%
Ariadni	AYF-103P-	AYF-103P-277-	1-20	1-44	1-15	1-27	100%-1%
Maestro	MAF-6AM-	MAF-6AM-277-	1-15	1-20	1-11	1-20	100%-1%
	MSCF-6AM-	MSCF-6AM-277-	1-15	1-20	1-11	1-20	100%-1%
Maestro Wireless	MRF2-F6AN-DV-		1-15	1-33	1-11	1-27	100%-1%
RadioRA 2	RRD-F6AN-DV-		1-15	1-33	1-11	1-27	100%-1%
HomeWorks QS	HQRD-F6AN-DV		1-15	1-33	1-11	1-27	100%-1%
Interfaces ¹	PHPM-3F-120	-	1-41	-	1-31	-	100%-1%
	PHPM-3F-DV		1-41	1-88	1-31	1-72	100%-1%
GP Dimming Panels	Various		1-41	1-88	1-31	1-72	100%-1%
EcoSystem Controls:							
PowPak dimming module with EcoSystem	RMJ-ECO32-DV-B		32 per EcoSystem link				100%-1%
	FCJ-ECO		3 per EcoSystem link ²				100%-1%
Energi Savr Node with EcoSystem	QSN-1ECO-S, QSN-2ECO-S		64 per EcoSystem link				100%-1%
GRAFIK Eye QS with EcoSystem	QSGRJ-_E, QSGR-_E	-	64 per EcoSystem link				100%-1%
Quantum	Various		64 per EcoSystem link				100%-1%

¹ For use with 3-wire controls or Commercial Systems, RadioRA 2 Systems or Home Systems applications.

² Up to 3 drivers controlled as a single zone (broadcast EcoSystem).

DIMMING COMPATIBILITY

L.T.F.® 0-10V Drivers

0	1	0
---	---	---

120V-277V driver (Universal dimming including 0–10V)

Full manufacturer's specification sheets can be found at stickbulb.com/drivers/010

Low-Voltage Compatible Dimmer brands: Crestron, Lutron, Leviton

For assistance selecting controls, contact LTF at +1 (847) 498-5832 or LTFsales@LTFtechnology.com

Brand	Part number
Crestron	CLS-C6
Crestron	CLS-C6M
Crestron	CLS-C6EX
Crestron	CLS-C6MEX
Crestron	CLS-EXP-DIM
Crestron	CLS-EXP-DIMU
Crestron	CLX-2DIM8
Crestron	DIN-1DIM4
Crestron	DIN-1DIMU4
Crestron	CLW-DIMEX-E
Crestron	CLW-DIMEX-P
Crestron	CLW-DIMSWEX-E
Crestron	CLW-DIMSWEX-P
Crestron	GLX-DIM6
Crestron	GLXX-2DIM8
Crestron	P-DIMEX
Crestron	CLW-DELVEX-E
Crestron	CLW-DELVEX-P

Brand	Part number
Lutron	DVCL-153P
Lutron	DVELV-303P
Lutron	HQRD-6A
Lutron	HQRD-6NA-
Lutron	NTELV-300-
Lutron	NTELV-600-
Lutron	NVELV-600-
Lutron	VTELV-600M
Lutron	MAELV-600-
Lutron	MSCELV-600M
Lutron	MIRELV-600-
Lutron	MRF2-6ELV-120-
Lutron	SELV-300P
Lutron	CTELV-303P
Lutron	SELV-600-

Brand	Part number
Leviton	Model 6615
Leviton	Model 6672
Leviton	Model 6674
Leviton	Model IPL06
Leviton	Model IPE04
Leviton	Model IPI06
Leviton	Model VP106
Leviton	Model VPE04
Leviton	Model VPM06
Leviton	Model VRE04
Leviton	Model VRM10

CLEANING INSTRUCTIONS

All of our wood and metal products should be dusted by hand with a dry Swiffer pad (or equivalent) on a regular schedule to maintain surface integrity. **It is imperative that none of our products come into contact with bleach, vinegar, lemon juice or any household product which may contain these or other solvents.**

If any part of one of our fixtures becomes soiled with dried residue or grime, wipe the affected area with a soft cloth dampened very lightly with warm water and immediately wipe dry with another soft cloth. If this does not complete the task, wipe with a cloth soaked in diluted mild liquid dish soap and again immediately dry.

Fingerprints on our Nickel-plated, Brass-plated, and Blackened metal hardware can be removed with a clean, dry, soft cloth. We recommend an ultra-fine, textureless microfiber cleaning cloth (as one uses to clean glass). Stubborn stains **on Nickel only** may be removed with a light application of Windex.

All of our Brass hardware is treated with a protective coating to prevent tarnish. It should need no more than a wipe with a clean, dry, soft cloth to remove fingerprints and dust.

Brushed metal surfaces should be buffed in the direction of the grain.

For scratches in wood we highly recommend Claphams beeswax, which is non-toxic and can be applied by hand. Rub a small amount into the scratch area and buff with a dry cloth.

BIG DIAMOND

BIG-DIA

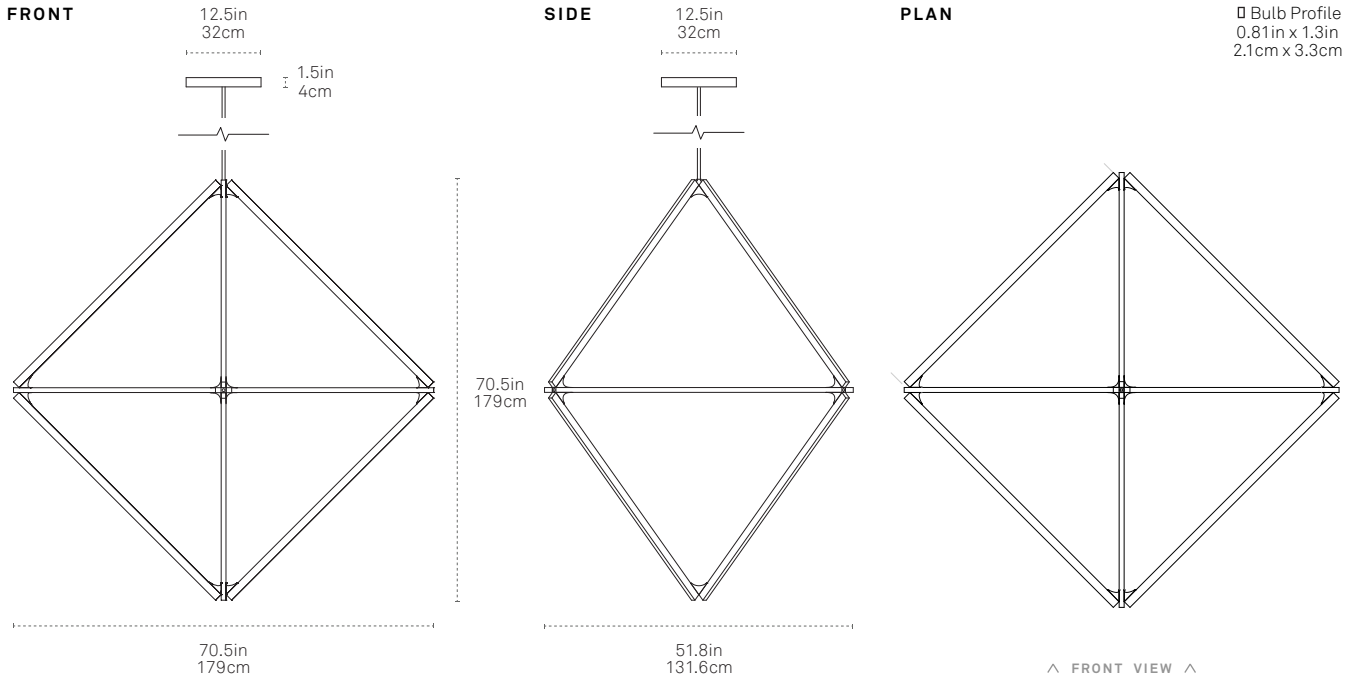

SPECIFY PRODUCT OPTIONS:

MODEL

BIG-DIA

WOOD	METAL	COLOR TEMP	DRIVER	OUTPUT	STEM	CEILING
<input type="checkbox"/>	<input type="checkbox"/>	<input type="checkbox"/>	<input type="checkbox"/>	<input type="checkbox"/>	<input type="checkbox"/>	<input type="checkbox"/>

DESIGN

© 2017

MATERIALS

LED, Sustainably Sourced or Reclaimed Wood, Brass

FEATURES

Fully Dimmable
 Ships assembled
 60-inch drop stem included

CERTIFICATIONS



ORIGIN OF MANUFACTURE

New York City, USA

FIXTURE WEIGHT

27.2 lbs / 12.3 kg

SHIPPING DIMENSIONS

Ships assembled in a wooden crate.
 61 in x 53 in x 43 in
 155 cm x 135 cm x 109 cm
 200 lbs / 90.7 kg

LIGHT SPECIFICATION

Standard Brightness LEDs :
 2,976 Lumens / 94 CRI (3000K) /
 96W Power draw

WOOD*

Maple	M A
American Walnut	W A
Ebonized Oak	E O
Heart Pine (Reclaimed)**	H P
Water Tower Redwood (Reclaimed)**	W T

* Custom options available upon approval.
 ** Our reclaimed woods exhibit variations in tone and grain.

METAL*

Brushed Nickel	B N
Polished Nickel	P N
Brushed Brass	B B
Polished Brass	P B
Blackened	B L

* Custom options available upon approval.

COLOR TEMP

2400K	2 4 0 0
2700K	2 7 0 0
3000K (Standard)	3 0 0 0
4000K	4 0 0 0

DRIVER & DIMMING OPTIONS

120V (2-wire+G Forward phase 1% dimming)	1 2 0
120V-277V (3-wire+G 1% dimming)	2 7 7
120V-277V (Universal dimming including 0-10V)**	0 1 0

** Recommended for European orders

LIGHT OUTPUT

Standard Brightness - 12V (Dimmable)	S B
--------------------------------------	------------

STEM LENGTH*

60" length of 1/2" rigid steel stem	0 6 0
120" length of 1/2" rigid steel stem	1 2 0
180" length of 1/2" rigid steel stem	1 8 0

* Drop stem can be cut to length on site. 60" is included; contact a sales representative for 120" and 180" pricing.

CEILING

Flat Ceiling	F
Sloped Ceiling	S

DIMMING COMPATIBILITY

Lutron Hi-lume 1% 2-Wire LTE Standard & High Brightness

1 2 0

120V driver (2-wire+G Forward phase 1% dimming)

Full manufacturer's specification sheets can be found at stickbulb.com/drivers/120

Compatible Controls: Lutron Neutral-wire Dimmers

For assistance selecting controls contact Lutron at 1.877.346.5338 or LEDs@lutron.com

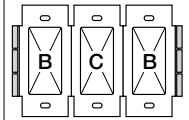
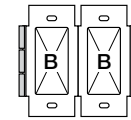
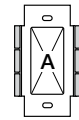

Product	Part Number	Low-End Setting/Load-Type Setting ¹	Drivers per Control		
			A: Not Ganged	B: End of Gang	C: Middle of Gang
RadioRA 2 adaptive dimmer	RRD-6NA-	Hi-lume 1% 2-Wire LTE LED ²	1-10, 400 W max	1-10, 400 W max	1-10, 400 W max
RA2 Select/RadioRA 2 600 W dimmer	RRD-6ND	Hi-lume 1% 2-Wire LTE LED ²	1-8, 350 W max	1-8, 350 W max	1-8, 350 W max
RadioRA 2 1000 W dimmer	RRD-10ND-	Set Device type to "INC/MLV Neutral Dimmer"; Set High-End Trim to 99%; Set Low-End Trim to 35%	1-13	1-13	1-13
RadioRA 2 Architectural RF GRAFIK T phase selectable dimmer	RRT-G5NEW-	Trim low-end per APM App Note (Lutron P/N 048534)	1-10, 400 W max	1-10, 400 W max	1-10, 400 W max
RadioRA 2 Architectural RF GRAFIK T dimmer	RRT-G25LW-	Trim low-end per APM App Note (Lutron P/N 048534)	1-10, 400 W max	1-10, 400 W max	1-10, 400 W max
RadioRA 2 C•L hybrid seeTouch keypad	RRD-HN	Hi-lume 1% 2-Wire LTE LED ²	1-10, 200 W max	1-10, 200 W max	1-10, 200 W max
RadioRA 2 GRAFIK T C•L hybrid keypad	RRT-GH	Hi-lume 1% 2-Wire LTE LED ²	1-10, 400 W max	1-10, 400 W max	1-10, 400 W max
HomeWorks QS adaptive dimmer	HQRD-6NA-	Hi-lume 1% 2-Wire LTE LED ²	1-10, 400 W max	1-10, 400 W max	1-10, 400 W max
HomeWorks QS 600 W dimmer	HQRD-6ND-	Hi-lume 1% 2-Wire LTE LED ²	1-8, 350 W max	1-8, 350 W max	1-8, 350 W max
HomeWorks QS 1000 W dimmer	HQRD-10ND-	Hi-lume 1% 2-Wire LTE LED ²	1-13	1-13	1-13
Maestro Wireless 600 W dimmer	MRF2-6ND-120-	Trim low-end per APM App Note (Lutron P/N 048370)	1-8, 350 W max	1-8, 350 W max	1-8, 350 W max
Vive Maestro Wireless 600 W dimmer	MRF2S-6ND-120-	Trim low-end per APM App Note (Lutron P/N 048370)	1-8, 350 W max	1-8, 350 W max	1-8, 350 W max
HomeWorks QS GRAFIK T hybrid keypad	HQRT-GH	Hi-lume 1% 2-Wire LTE LED ²	1-10, 400 W max	1-10, 400 W max	1-10, 400 W max
HomeWorks QS Architectural GRAFIK T dimmer	HQRT-G25LW-	Hi-lume 1% 2-Wire LTE LED ²	1-10, 400 W max	1-10, 400 W max	1-10, 400 W max
HomeWorks QS Architectural GRAFIK T phase selectable dimmer	HQRT-G5NEW-	Hi-lume 1% 2-Wire LTE LED ²	1-10, 400 W max	1-10, 400 W max	1-10, 400 W max
HomeWorks QS designer C•L hybrid seeTouch keypad	HQRD-HN	Hi-lume 1% 2-Wire LTE LED ²	1-10, 200 W max	1-10, 200 W max	1-10, 200 W max
GRAFIK T C•L 250 W dimmer	GT-250M-, GTJ-250M-	Set low-end trim per dimmer installation instructions	1-10, 400 W max	1-10, 400 W max	1-10, 400 W max
Caséta Wireless Pro 1000 W dimmer	PD-10NXD-	Trim low-end per instructions at casetawireless.com/lowend	1-13	1-13	1-13
Caséta Wireless phase selectable dimmer	PD-5NE-	Trim low-end per instructions at casetawireless.com/lowend	1-20, 400 W max	1-20, 400 W max	1-20, 400 W max

¹ Setting the low-end trim and load type is necessary to ensure optimal performance and 1% dimming capability.

² Also listed as "LED Lutron A-Series 2-Wire" or "Hi-Lume A-Series LTE LED Driver 2-Wire" in previous software releases.

(TO BE CONTINUED ON NEXT PAGE)

DIMMING COMPATIBILITY

(CONTINUED from

1	2	0
---	---	---

)

Compatible Controls: Lutron Non-Neutral Dimmers

For assistance selecting controls contact Lutron at 1.877.346.5338 or LEDs@lutron.com

Product	Part Number	Dimmers per Control	Low-End Setting/Load-Type Setting ¹		
Ariadni C•L 250 W dimmer	AYCL-253P-	Set low-end trim dial to 1 o'clock. Adjust slightly if needed.	1-8, 350 W max	1-8, 350 W max	1-8, 350 W max
Ariadni C•L 150 W dimmer	TGCL-153P-, AYCL-153P-	Set low-end trim dial to 1 o'clock. Adjust slightly if needed.	1-6, 250 W max	1-6, 250 W max	1-6, 250 W max
Diva C•L 250 W dimmer	DVCL-253P-, DVSCCL- 253P-	Set low-end trim dial to 10 o'clock. Adjust slightly if needed.	1-8, 350 W max	1-8, 350 W max	1-8, 350 W max
Diva C•L 150 W dimmer	DVCL-153P-, DVSCCL- 153P-	Set low-end trim dial to 10 o'clock. Adjust slightly if needed.	1-6, 250 W max	1-6, 250 W max	1-6, 250 W max
Nova Tr C•L 250 W dimmer	NTCL-250-	Set low-end trim dial to 10 o'clock. Adjust slightly if needed.	1-10, 400 W max	1-10, 400 W max	1-10, 400 W max
Lumea C•L 150 W dimmer	LECL-153P-	Set low-end trim dial to 10 o'clock. Adjust slightly if needed.	1-6, 250 W max	1-6, 250 W max	1-6, 250 W max
Sylark C•L 150 W dimmer	SCL-153P-	Set low-end trim dial to 10 o'clock. Adjust slightly if needed.	1-6, 250 W max	1-6, 250 W max	1-6, 250 W max
Contour C•L 150 W dimmer	CTCL-153P-	Set low-end trim dial to 10 o'clock. Adjust slightly if needed.	1-6, 250 W max	1-6, 250 W max	1-6, 250 W max
myRoom DIN power module	MQSE-4A1-D	1-6 (per output); 1 A maximum driver input current	Hi-lume 1% 2-Wire LTE LED ²		
HomeWorks QS DIN power module	LQSE-4A1-D	1-6 (per output); 1 A maximum driver input current	Hi-lume 1% 2-Wire LTE LED ²		
HomeWorks QS Phase Adaptive DIN power module	LQSE-4A-120-D	1-6 (per output); 2 A maximum driver input current	Hi-lume 1% 2-Wire LTE LED ²		
HomeWorks QS wallbox power module	HQRJ-WPM-6D-120	2-10 (per output); 26 total per module	Hi-lume 1% 2-Wire LTE LED ²		
HomeWorks wallbox power module	HWI-WPM-6D-120	2-10 (per output); 26 total per module	Set load type to "GRX-FDBI or GRX-TVI"		
GRAFIK Eye QS control unit	QSGR-, QSGRJ-	2-10 (per output); 26 total per unit	Set load type to "Fluorescent Module"		
GRAFIK Eye 3000 control unit	GRX-3100-, GRX-3500-	2-10 (per output); 26 total per module	Set load type to "GRX-FDBI" or "GRX-TVI"		
RPM-4U module (LCP, HomeWorks QS, GRAFIK Systems, Quantum)	HW-RPM-4U-120, LP-RPM-4U-120	2-26 (per output); 26 total per module	Hi-lume 1% 2-Wire LTE LED ² Set load type to "2-1"		
RPM-4A module (LCP, HomeWorks QS, GRAFIK Systems, Quantum)	HW-RPM-4A-120, LP-RPM-4A-120	1-13 (per output); 26 total per module	Hi-lume 1% 2-Wire LTE LED ² Set load type to "2-1"		
GP dimming panels	Various	1-26	Set load type to "2-1"		

¹ Setting the low-end trim and load type is necessary to ensure optimal performance and 1% dimming capability.

² Also listed as "LED Lutron A-Series 2-Wire" or "Hi-lume A-Series LTE LED Driver 2-Wire" in previous software releases.

DIMMING COMPATIBILITY

Lutron Hi-Lume 1% EcoSystem/3-Wire L3D Standard & High Brightness

2	7	7
---	---	---

120-277V driver (3-wire+G 1% dimming)

Full manufacturer's specification sheets can be found at stickbulb.com/drivers/277

Compatible Controls

For assistance selecting controls, contact Lutron at 1.877.346.5338 or LEDs@lutron.com

Product	Part Number		Drivers per Control				Measured Light Output Range
			40 W Driver		50 W Driver		
	120 V ~	277 V ~	120 V ~	277 V ~	120 V ~	277 V ~	
3-wire Controls:							
Nova T	NTF-10-	NTF-10-277-	1-41	1-44	1-31	1-36	100%-1%
	NTF-103P-	NTF-103P-277-	1-20	1-33	1-15	1-27	100%-1%
Nova	NF-10-	NF-10-277-	1-41	1-44	1-31	1-36	100%-1%
	NF-103P-	NF-103P-277-	1-20	1-33	1-15	1-27	100%-1%
Skylark	SF-10P-	SF-12P-277-	1-20	1-33	1-15	1-27	100%-1%
	SF-103P-	SF-12P-277-3	1-20	1-33	1-15	1-27	100%-1%
Diva	DVF-103P-	DVF-103P-277-	1-20	1-33	1-15	1-27	100%-1%
	DVSCF-103P-	DVSCF-103P-277-	1-20	1-33	1-15	1-27	100%-1%
Ariadni	AYF-103P-	AYF-103P-277-	1-20	1-44	1-15	1-27	100%-1%
Maestro	MAF-6AM-	MAF-6AM-277-	1-15	1-20	1-11	1-20	100%-1%
	MSCF-6AM-	MSCF-6AM-277-	1-15	1-20	1-11	1-20	100%-1%
Maestro Wireless	MRF2-F6AN-DV-		1-15	1-33	1-11	1-27	100%-1%
RadioRA 2	RRD-F6AN-DV-		1-15	1-33	1-11	1-27	100%-1%
HomeWorks QS	HQRD-F6AN-DV		1-15	1-33	1-11	1-27	100%-1%
Interfaces ¹	PHPM-3F-120	-	1-41	-	1-31	-	100%-1%
	PHPM-3F-DV		1-41	1-88	1-31	1-72	100%-1%
GP Dimming Panels	Various		1-41	1-88	1-31	1-72	100%-1%
EcoSystem Controls:							
PowPak dimming module with EcoSystem	RMJ-ECO32-DV-B		32 per EcoSystem link				100%-1%
	FCJ-ECO		3 per EcoSystem link ²				100%-1%
Energi Savr Node with EcoSystem	QSN-1ECO-S, QSN-2ECO-S		64 per EcoSystem link				100%-1%
GRAFIK Eye QS with EcoSystem	QSGRJ-_E, QSGR-_E	-	64 per EcoSystem link				100%-1%
Quantum	Various		64 per EcoSystem link				100%-1%

¹ For use with 3-wire controls or Commercial Systems, RadioRA 2 Systems or Home Systems applications.

² Up to 3 drivers controlled as a single zone (broadcast EcoSystem).

DIMMING COMPATIBILITY

L.T.F.® 0-10V Drivers

0	1	0
---	---	---

120V-277V driver (Universal dimming including 0–10V)

Full manufacturer's specification sheets can be found at stickbulb.com/drivers/010

Low-Voltage Compatible Dimmer brands: Crestron, Lutron, Leviton

For assistance selecting controls, contact LTF at +1 (847) 498-5832 or LTFsales@LTFtechnology.com

Brand	Part number
Crestron	CLS-C6
Crestron	CLS-C6M
Crestron	CLS-C6EX
Crestron	CLS-C6MEX
Crestron	CLS-EXP-DIM
Crestron	CLS-EXP-DIMU
Crestron	CLX-2DIM8
Crestron	DIN-1DIM4
Crestron	DIN-1DIMU4
Crestron	CLW-DIMEX-E
Crestron	CLW-DIMEX-P
Crestron	CLW-DIMSWEX-E
Crestron	CLW-DIMSWEX-P
Crestron	GLX-DIM6
Crestron	GLXX-2DIM8
Crestron	P-DIMEX
Crestron	CLW-DELVEX-E
Crestron	CLW-DELVEX-P

Brand	Part number
Lutron	DVCL-153P
Lutron	DVELV-303P
Lutron	HQRD-6A
Lutron	HQRD-6NA-
Lutron	NTELV-300-
Lutron	NTELV-600-
Lutron	NVELV-600-
Lutron	VTELV-600M
Lutron	MAELV-600-
Lutron	MSCELV-600M
Lutron	MIRELV-600-
Lutron	MRF2-6ELV-120-
Lutron	SELV-300P
Lutron	CTELV-303P
Lutron	SELV-600-

Brand	Part number
Leviton	Model 6615
Leviton	Model 6672
Leviton	Model 6674
Leviton	Model IPL06
Leviton	Model IPE04
Leviton	Model IPI06
Leviton	Model VP106
Leviton	Model VPE04
Leviton	Model VPM06
Leviton	Model VRE04
Leviton	Model VRM10

CLEANING INSTRUCTIONS

All of our wood and metal products should be dusted by hand with a dry Swiffer pad (or equivalent) on a regular schedule to maintain surface integrity. **It is imperative that none of our products come into contact with bleach, vinegar, lemon juice or any household product which may contain these or other solvents.**

If any part of one of our fixtures becomes soiled with dried residue or grime, wipe the affected area with a soft cloth dampened very lightly with warm water and immediately wipe dry with another soft cloth. If this does not complete the task, wipe with a cloth soaked in diluted mild liquid dish soap and again immediately dry.

Fingerprints on our Nickel-plated, Brass-plated, and Blackened metal hardware can be removed with a clean, dry, soft cloth. We recommend an ultra-fine, textureless microfiber cleaning cloth (as one uses to clean glass). Stubborn stains **on Nickel only** may be removed with a light application of Windex.

All of our Brass hardware is treated with a protective coating to prevent tarnish. It should need no more than a wipe with a clean, dry, soft cloth to remove fingerprints and dust.

Brushed metal surfaces should be buffed in the direction of the grain.

For scratches in wood we highly recommend Claphams beeswax, which is non-toxic and can be applied by hand. Rub a small amount into the scratch area and buff with a dry cloth.